



High current connectors

Reliable solutions

High current connectors

Made in Switzerland

Characteristics:

- 160 A - 600 A
- Robust housing
- 4- and 5-poles
- High reliability
- Compact design
- IP67
- Finger touch protection
- Designed for high temperatures
- Vibration resistant

Applications:

- Tunnel construction
- Marine
- Railway
- Military
- Industry
- Construction site
- Event technology
- Mining
- Chemistry



Table of contents

Rauscher & Stoecklin	4
R&S Group	5
High current connectors brief portrait	6
Areas of application	7
Terminology	8
Structure of a connector	9
Product portfolio	10
Value proposition	
Contact system	12
Safety	13
Maintenance & assembly	14
Housing	15
Options	16
Certifications	17
D-Line connector 160 A	18
C-Line connector 200 A / 250 A	30
B-Line connector 250 A / 315 A / 400 A	42
A-Line connector 500 A / 600 A	54
Connector unit CUMI	66
Connector unit CUBC	72
Connector unit CUCB	78
Applications	86
Notes	88

Long tradition

Firmly anchored in Switzerland

Electricity is one of the most important sources of energy and driving forces of modern society.

With almost a century of experience, we are the right partner for high-quality electrotechnical products and systems for energy distribution.

Our product portfolio

- Transformers
- Railway switches
- High-current connectors
- House service connection systems
- Switchgear

Because of our flexibility and urge towards innovation, we are a reliable partner, capable of solving all challenges presented to us by our customers. With our high-quality electrotechnical products and sustainable, innovative solutions we are a trusted partner to our customers. Experienced long-term employees and junior employees with the will and ambition to continuously learn are the foundation of our company.

Our company is certified to all established standards.



Our production site in Sissach

More safety, more flexibility

Rauscher & Stoecklin - a company of the R&S Group

The companies of the R&S have a long-standing history and experience in manufacturing power products with the ambition for improvement and innovation.

The R&S Group, founded in 2012 is an international oriented Group with its headquarters in Sissach, Switzerland and offices worldwide.

The success of the R&S is built upon:

- Longtime experience of the different companies in their particular core competencies
- Highly motivated and trained employees
- Products based on proven technologies that go hand in hand with innovative and efficient manufacturing processes

The results are products with highest possible quality and reliability for our customers.

Companies of R&S

- Rauscher & Stoecklin
Distribution transformers, railway switches, high current connectors
- SERW
HV and MV switching devices
- ZREW Transformers
Power transformers
- Tesar
Cast resin transformers, distribution transformers, instrument transformers

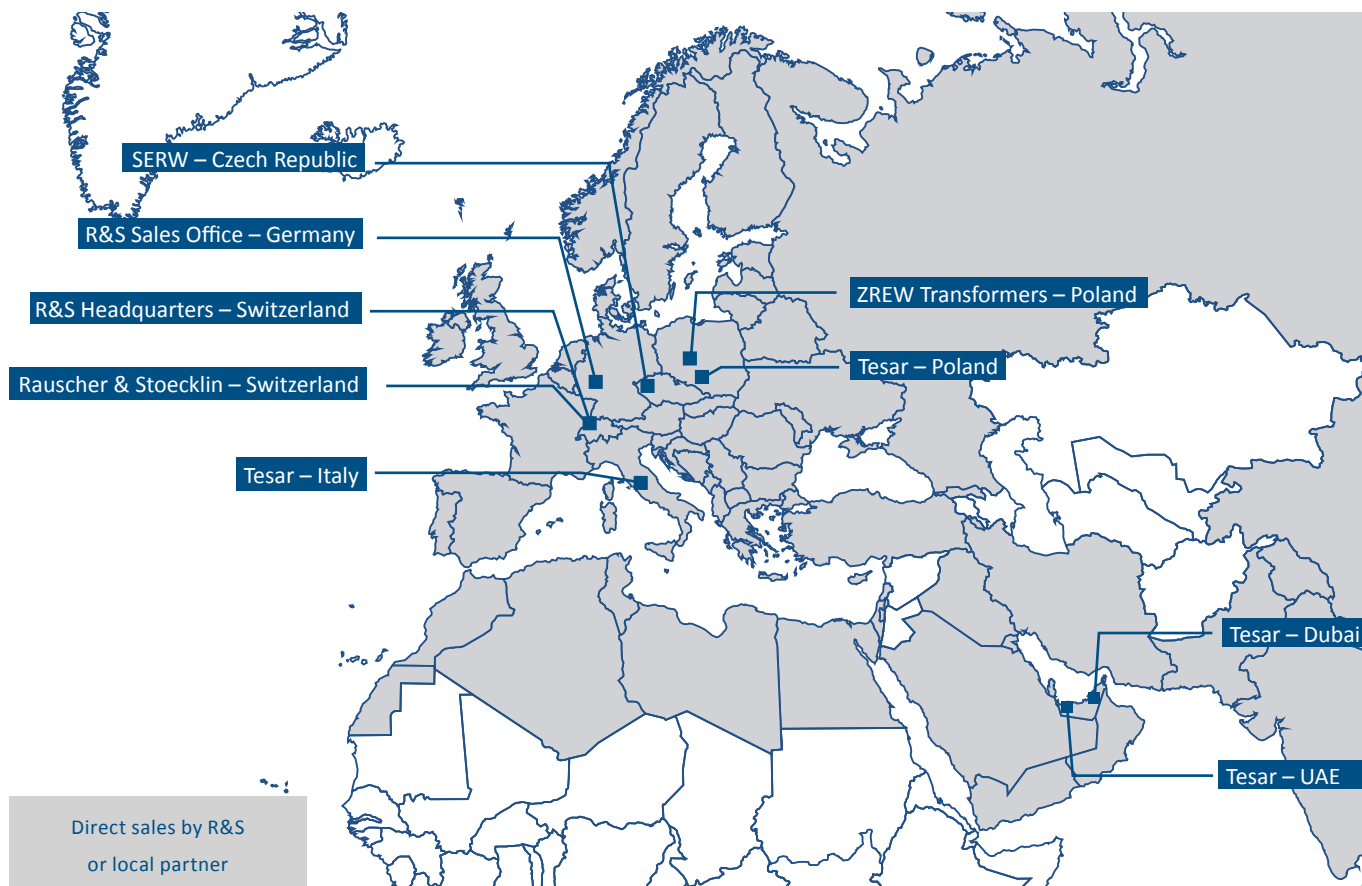

Our offices worldwide

High current connectors

Developed for eternity

Knowledge of the entire electrical industry combined.

Connectors for challenging applications

In applications where high current connectors are used, safety, quality and reliability are the top priorities for customers. In order to fulfill this task, all these properties were bundled into one product range. Thus, all customers receive a product with the highest degree of performance.

Whether in tunnel construction, where extremely mechanical strength is required or railway applications where vibration-proof is of highest importance, the Rauscher & Stoecklin connectors are always the right choice.

Customized solutions

If standard solutions do not meet all the requirements of an application, customer-specific solutions are made upon request.

In doing so, the customer is involved in each development step, thus enabling us to come up with a perfect solution. In this area, Rauscher & Stoecklin has extensive know-how and numerous reference projects.



MC C-Line



MC B-Line

Areas of application

Connectors for every task

Versatile applications for Rauscher & Stoecklin connectors.



Tunnel construction

Most used high current connectors in tunnel construction. Our products are characterized by reliability and the highest service life.



Marine

Seawater resistant connectors and individual connector units fulfill all requirements.



Construction site

Numerous protection mechanisms make the Rauscher & Stoecklin connectors the most safe products of the construction site.



Railway

Customized solutions and vibration-proof connectors allow use in the railway industry.



Mining

Compact connectors can be easily mounted on every mining electrical equipment.



Military

The highly resistant connectors are suited also for military applications.

Connector

Terminology

Structure of an electrical connection

1. Power source
2. Connector unit
3. Panel mounted socket angled
4. Plug

5. Cable
6. Coupling
7. Panel mounted inlet
8. Machine / Electrical consumer

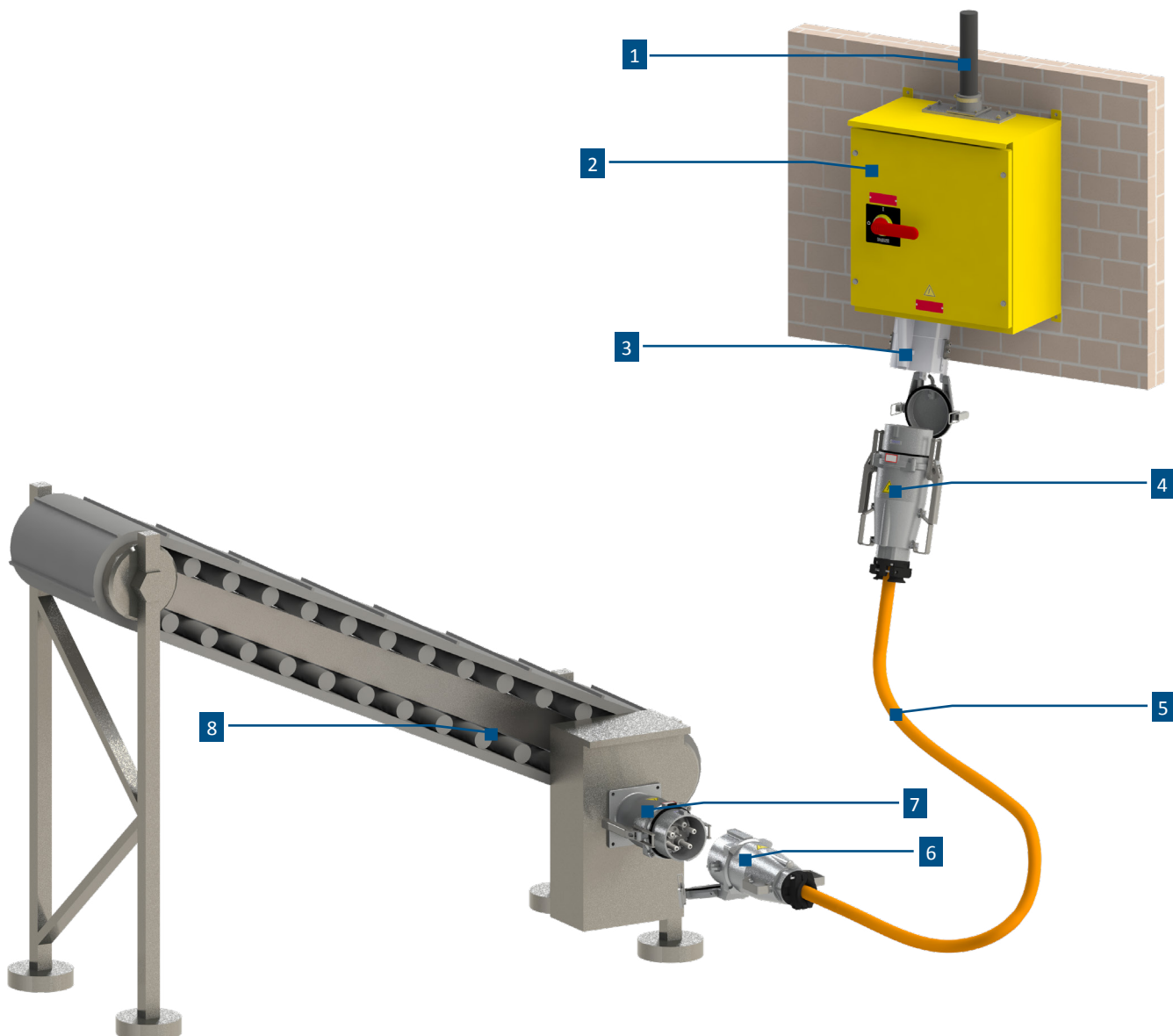

Structure of a connector

Perfection down to the smallest detail

Structure of a connector

1. Cable gland IP67, bell shaped entry for easy assembly
2. Rubber sealing ring, protection from water and dust
3. Cover coupling, protection from dirt
4. Power pins, silver-plated contacts for enhanced energy transmission
5. Finger touch protection, maximum safety for user
6. Pilot contact, implemented as standard
7. Earthing pin, earthing of housing
8. Clamping bracket, mechanical closing operation
9. Segmented contact socket, segmented contact system for all weather conditions
10. Connections terminals, easy cabling

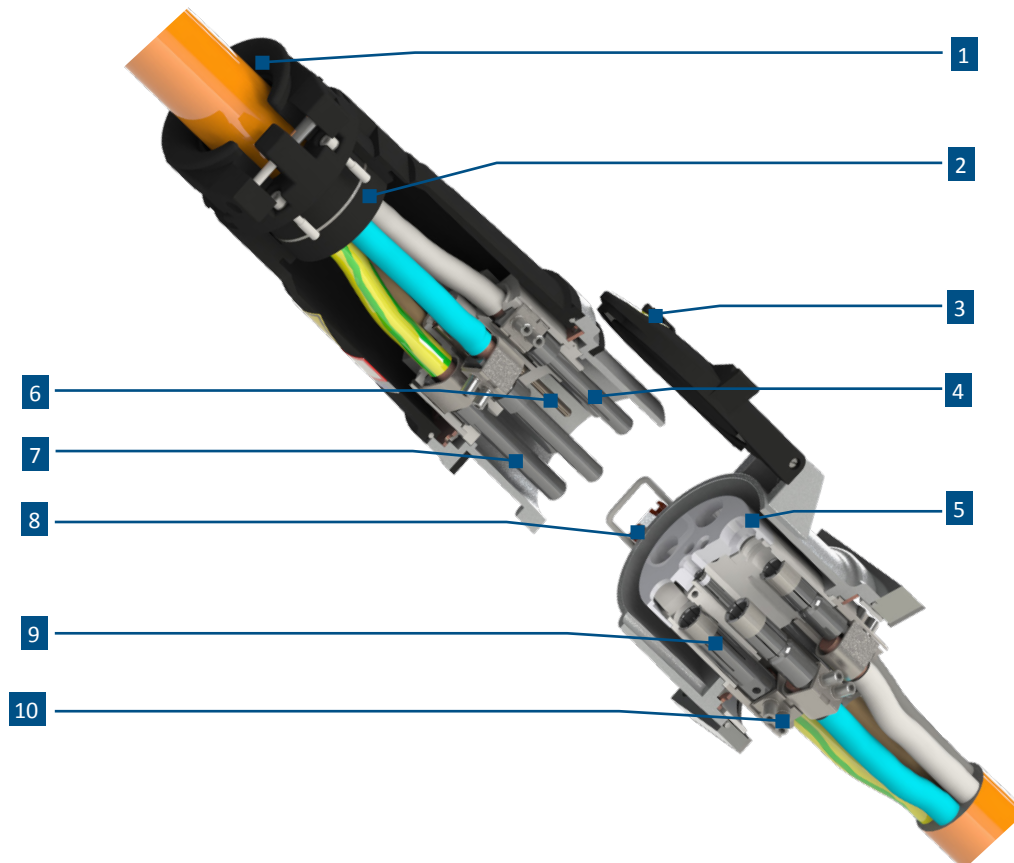

Product portfolio

The right solution for every application

The connector product portfolio covers almost all applications in the defined high current range.



D-Line and C-Line

The compact D-Line and C-Line connectors have a robust plastic housing and are perfect for applications with limited space conditions as well as for certain industries (chemistry, food industry).

Additional options allow use in a variety of applications.



A-Line and B-Line

The robust A-Line and B-Line connectors are ideal for applications (tunneling, mining), where high mechanical loads may arise. Furthermore, numerous options, such as the salt-water-resistant housing, make the connectors also suitable for marine applications.



Connector units

To ensure maximum safety for users, Rauscher & Stoecklin offers special connector units:

- CUMI (connector unit with mechanical interlock)
- CUBC (connector unit with block contactor)
- CUCB (connector unit with circuit breaker)

Product Overview

Male connector



MC
Plug



MCP
Panel Mounted Inlet



MCPA
Panel Mounted Inlet Angled



MCW
Wall Mounted Inlet

Female Connector



FC
Coupling



FCP
Panel Mounted Receptacle



FCPA
Panel Mounted Receptacle
Angled



FCW
Wall Mounted Receptacle

Energy Transmission

Efficient and reliable

Segmented contact system

The enlarged contact surfaces enable an efficient energy transfer.

Furthermore, low energy costs are achieved due to the silver-plated contacts, which have a low resistance and minimal power losses. The precise contact system is fully functional, even under severe vibrations.

- Low resistance
- Silver plated contacts
- Minimum power losses
- Self-cleaning contacts

Pilot contacts

The pilot contacts act as auxiliary contacts. They close lagging when inserting and open leading when removing the connector, thus providing an electrical interlocking, i.e. it prevents the plugging and pulling under load in the connector units.

The pilot contacts are fitted as standard in the entire product range, so there is no need for expensive retrofitting. The pilot contacts further help preserving the main power contacts from mechanical and electrical wear-out.



Segmented contact system

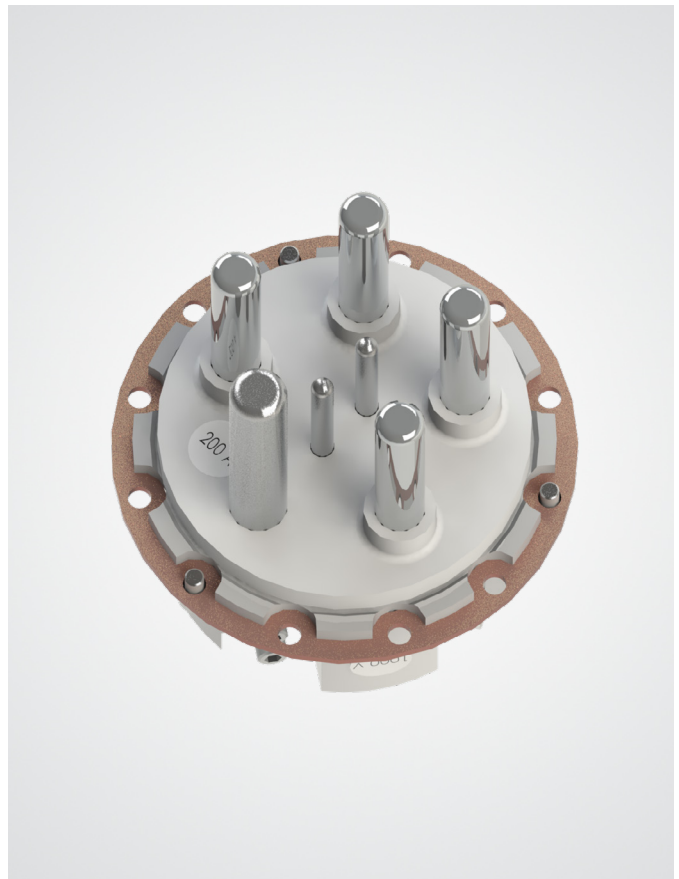

Pilot contacts

Safety

Anytime and everywhere guaranteed

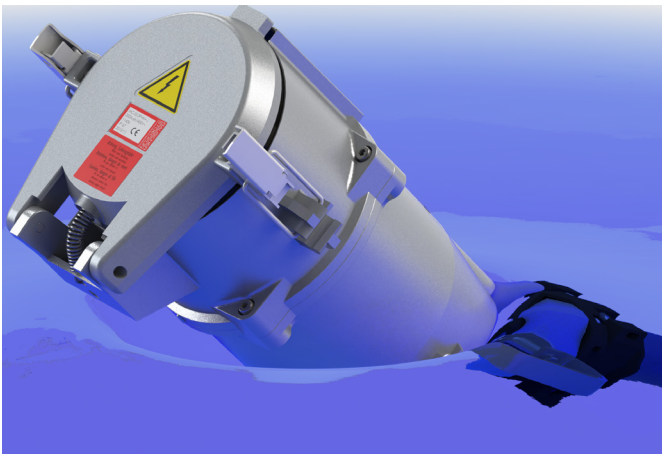

IP 67 / IP 55

The connectors are IP67. They are dust-proof and suitable for temporary immersions under water. The connector units are IP55, which means protected against dust and splashing water.

- Always reliable in adverse environmental conditions
- Suitable for high humidity applications
- Low maintenance (no dust / moisture penetration)
- High security ensured at all times

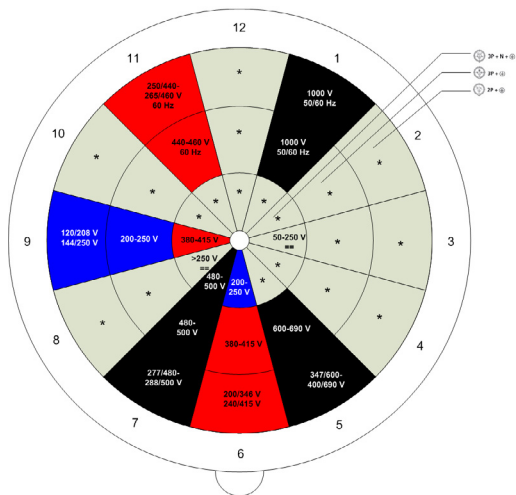

Voltage coding

Arrangement of the PE contact pin and bushing to prevent wrong plugging of various voltages and frequencies after the time setting in accordance with table 104 from EN 60309-2. The standard earthing contact specifies the time setting.



Finger touch protection

Each socket is equipped with a finger touch protection in order to safeguard the user against electrical shocks in the event of unintentional contact with live parts.

Maintenance & assembly

Fast and easy

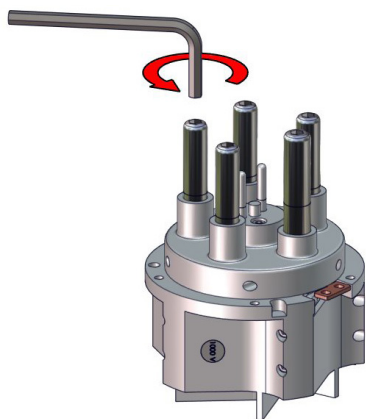

Quick exchanging of contacts

In the case of most conventional connectors, a time-consuming procedure is required to replace contact pins, since these are unnecessarily anchored. With the Rauscher & Stoecklin connectors, the contacts can be exchanged from the front with a simple hexagonal hex wrench. Thus, users can avoid costly and time-consuming maintenance work.

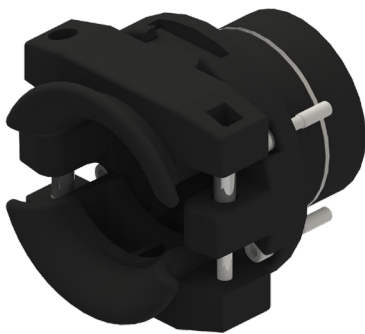

Assembly user-friendly

In order to simplify assembly for all applications, a bell-shaped cable gland with seal is included with each connector. This is extremely simple to install and provides additional help with strain relief.



Conventional tool

The connectors have been designed as uniformly as possible to provide various synergies, e.g. same screws, standard tool.

Developed for toughest conditions

Heat-resistant and robust

Robust housing

The connectors are designed for ambient temperatures from -40° C to + 100 ° C. This ensures full functionality at low and very high temperatures. This leads to significantly fewer plant failures (reduced risk of overheating) and reduced fire risk. Another important aspect for various industries, such as tunnel construction, construction sites, mines is the high robustness of the connectors. These can withstand loads of up to 2 tonnes.

IK code

The IK code is a coding system according to IEC / EN 50102 or IEC / EN 62262, which indicates the degree of protection by a housing against harmful external stresses. Each characteristic number of the IK code represents a stress relief value (see table).

The connectors of the C-Line and B-Line are IK10 classified.



IK - Code	IK01	IK02	IK03	IK04	IK05	IK06	IK07	IK08	IK09	IK10
Stress energy joule	0.14	0.2	0.35	0.5	0.7	1	2	5	10	20

Special applications

New challenges – New solutions

Customized solutions and accessories fulfill all requirements of the customers.

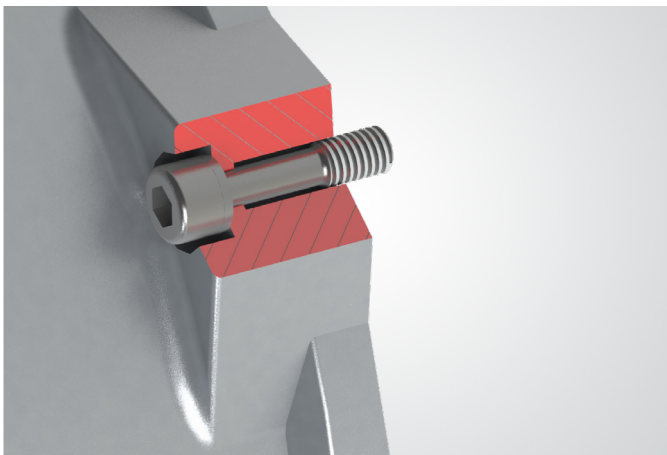

Vibration resistant screws

Wherever heavy machinery is supplied with electrical energy, strong vibrations are generally generated. For this reason, special vibration-proof connectors are available on request. Especially in the railway sector, in mines and in tunnel construction, this property is often desired by the customer.



Seawater resistant housing

In order to ensure the readiness of the connectors at all times even in salt-laden atmosphere (port), special seawater-resistant versions are available upon request. These are made of anodized aluminum for the plug-in connectors and the stainless steel for the connector units.

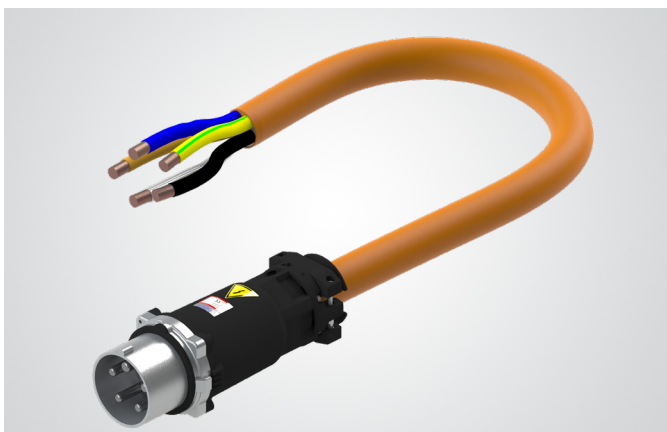

Harnessed connectors

On request, the connectors are available pre-harnessed.

Certifications

Marking of our products

All connectors comply with national and international standards.

Certification according to ISO 9001: 2015 & ISO 14001: 2015

The quality management and environmental management system of Rauscher & Stoecklin AG is certified according to the ISO 9001: 2015 & ISO14001: 2015 standard.

Basic

By means of the CE marking, a manufacturer in the European Union declares that a particular product satisfies the applicable requirements laid down in the relevant harmonization legislation, as demonstrated by the corresponding conformity assessment procedure.

Guidelines

- Low voltage directive 2014/35 / EU
- Electromagnetic compatibility (EMC) 2004/30 / EU
- Low-voltage switchgear combinations EN 61439-1: 2011
- Connectors for industrial applications EN 60309-1: 1999 + A1: 2007 + A2: 2012
- Electromagnetic interference (EMC) EN 61000-6-3/4: 2007 + A1: 2011
- Electromagnetic immunity (EMC) EN 61000-6-1: 2007
- Degree of protection by housing (IP code) EN 60529_1991 + A1_2000 + A2_2013
- wRoHS Directive 2011/65 / EU



Certificate

SQS herewith certifies that the company named below has a management system which meets the requirements of the standards specified below.

Rauscher & Stoecklin AG
Reuslistrasse 32
4450 Sissach
Switzerland

Scope of certification

Whole Company

Field of activity

Electrotechnical components and systems

Normative basis

ISO 9001:2015 **Quality Management System**
ISO 14001:2015 **Environmental Management System**
OHSAS 18001:2007 **Safety Management System**

Scope(s) 19

Validity 26.10.2015 – 25.10.2018
 Issue 26.10.2015

Reg. no. 11250



Swiss Association for Quality and Management Systems SQS
 Rometrasso 103 3052 Zellikofen Switzerland



D - Line

Technical Data



Technical Data	Unit	D - Line
Nominal current	A	160
Rated current	A	160
Rated voltage	V	1.000
Rated frequency	Hz	50 / 60
Withstand voltage (1 min / 50 Hz)	V	4.000
Protection grade		IP 67
Shock resistance		IK 10
Ambient temperature	°C	- 40 / + 100
Insulation resistance (Phase-phase and phase-earth)	MOhm	> 500
Comparative tracking index of the insert	CTI	> 600
Terminal cross-section (EN 60228 Class 5)	mm ²	35 - 150
max. cross section pilot cable, conductor (EN60228 Class 5)	mm ²	4
Diameter of cable	mm	34 - 66
Diameter of cable - separate pilot cable	mm	5 - 10

Technical modifications reserved

Structure

Structure of C-Line connector

1. Cable gland
2. Plastic housing
3. Connector insert
4. Connector collar

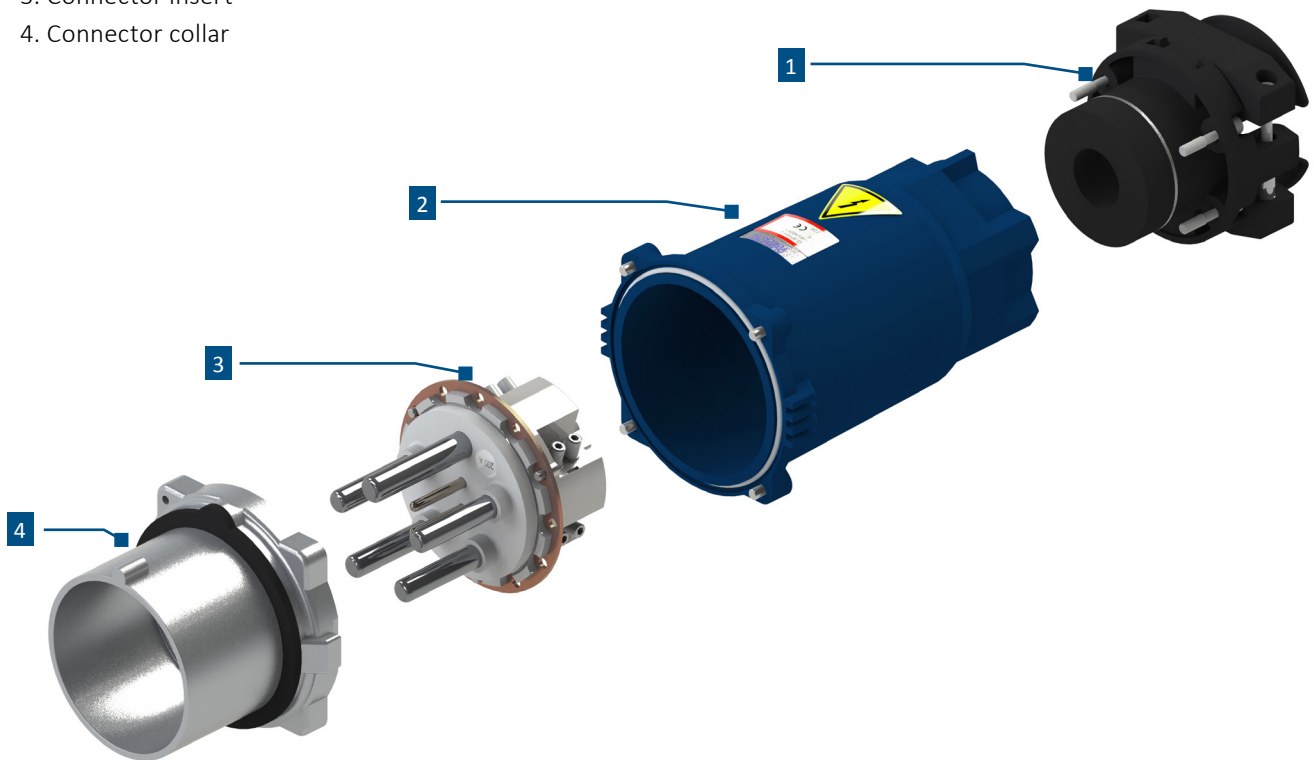

Locking system

Mechanically easy designed locking system, which reduces the force required during plugging and pulling.

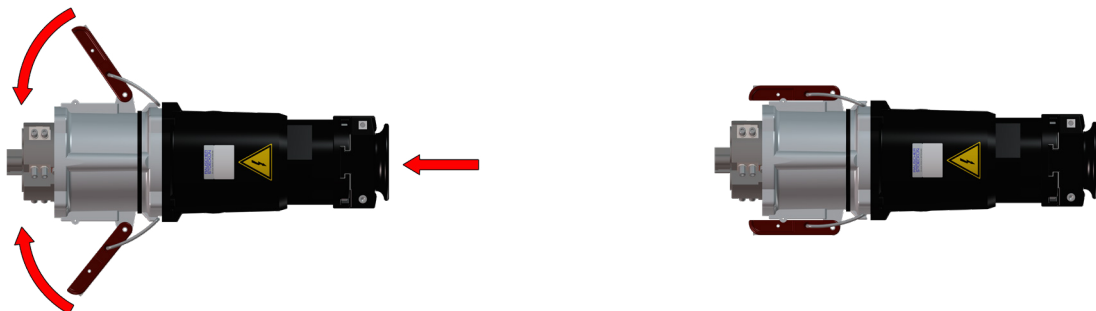

MC

Plug

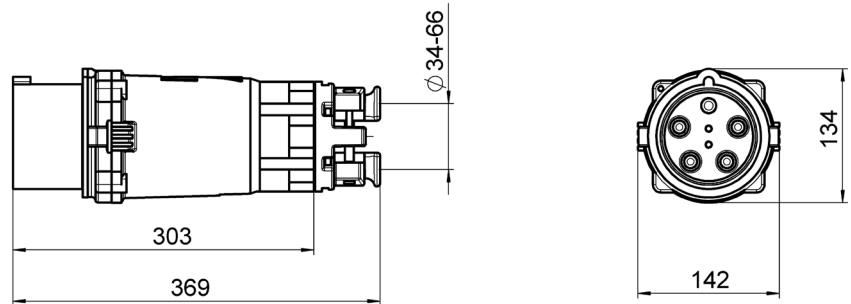

Current	No. of Poles	Voltage	Type designation	Article No.
160 A	4 (3L+PEN)	230V	MC-S4/160 230V-9h	25120
		400V	MC-S4/160 400V-6h	25121
		500V	MC-S4/160 500V-7h	25122
		690V	MC-S4/160 690V-5h	25123
		1000V	MC-S4/160 1000V-1h	25124
	5 (3L+N+PE)	230V	MC-S5/160 230V-9h	25130
		400V	MC-S5/160 400V-6h	25131
		500V	MC-S5/160 500V-7h	25132
		690V	MC-S5/160 690V-5h	25133
		1000V	MC-S5/160 1000V-1h	25134

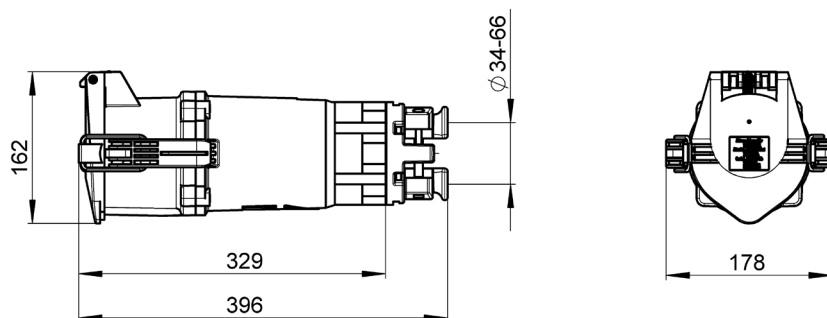

Current	No. of Poles	Voltage	Type designation	Article No.
160 A	4 (3L+PEN)	230V	FC-S4/160 230V-9h	25125
		400V	FC-S4/160 400V-6h	25126
		500V	FC-S4/160 500V-7h	25127
		690V	FC-S4/160 690V-5h	25128
		1000V	FC-S4/160 1000V-1h	25129
	5 (3L+N+PE)	230V	FC-S5/160 230V-9h	25135
		400V	FC-S5/160 400V-6h	25136
		500V	FC-S5/160 500V-7h	25137
		690V	FC-S5/160 690V-5h	25138
		1000V	FC-S5/160 1000V-1h	25139



MCW

Wall Mounted Inlet

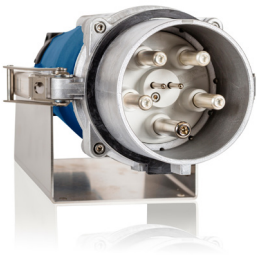
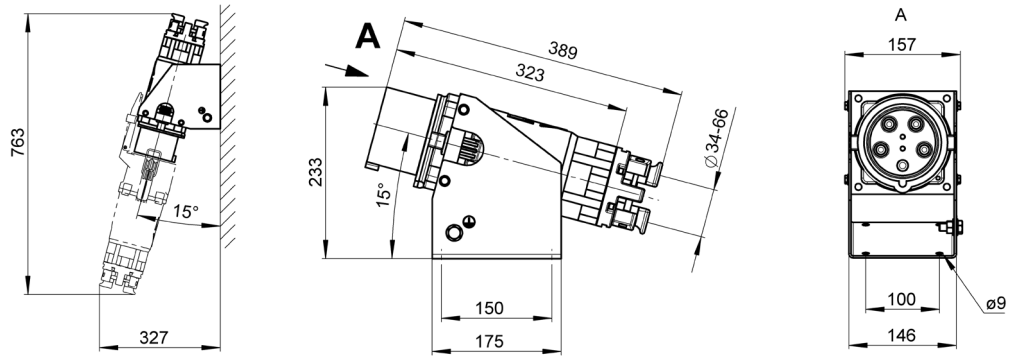

Current	No. of Poles	Voltage	Type designation	Article No.
160 A	4 (3L+PEN)	230V	MCW-S4/160 230V-9h	25140
		400V	MCW-S4/160 400V-6h	25141
		500V	MCW-S4/160 500V-7h	25142
		690V	MCW-S4/160 690V-5h	25143
		1000V	MCW-S4/160 1000V-1h	25144
	5 (3L+N+PE)	230V	MCW-S5/160 230V-9h	25150
		400V	MCW-S5/160 400V-6h	25151
		500V	MCW-S5/160 500V-7h	25152
		690V	MCW-S5/160 690V-5h	25153
		1000V	MCW-S5/160 1000V-1h	25154

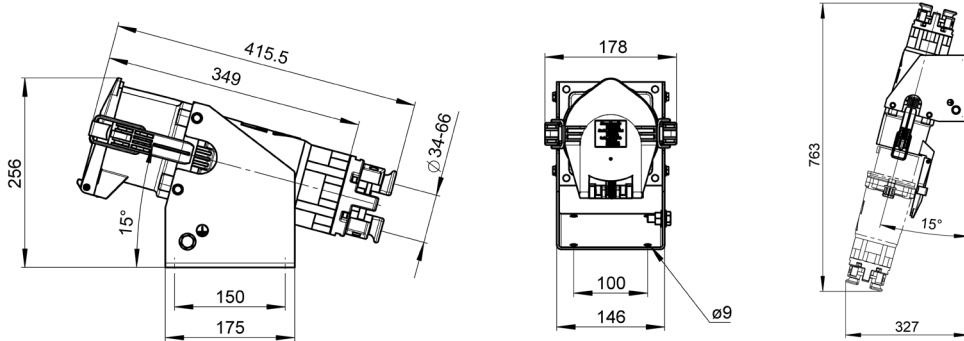

Current	No. of Poles	Voltage	Type designation	Article No.
160 A	4 (3L+PEN)	230V	FCW-S4/160 230V-9h	25145
		400V	FCW-S4/160 400V-6h	25146
		500V	FCW-S4/160 500V-7h	25147
		690V	FCW-S4/160 690V-5h	25148
		1000V	FCW-S4/160 1000V-1h	25149
	5 (3L+N+PE)	230V	FCW-S5/160 230V-9h	25155
		400V	FCW-S5/160 400V-6h	25156
		500V	FCW-S5/160 500V-7h	25157
		690V	FCW-S5/160 690V-5h	25158
		1000V	FCW-S5/160 1000V-1h	25159

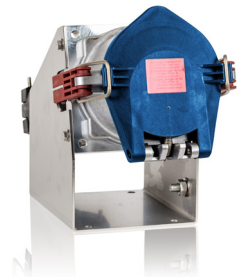

MCP

Panel Mounted Inlet

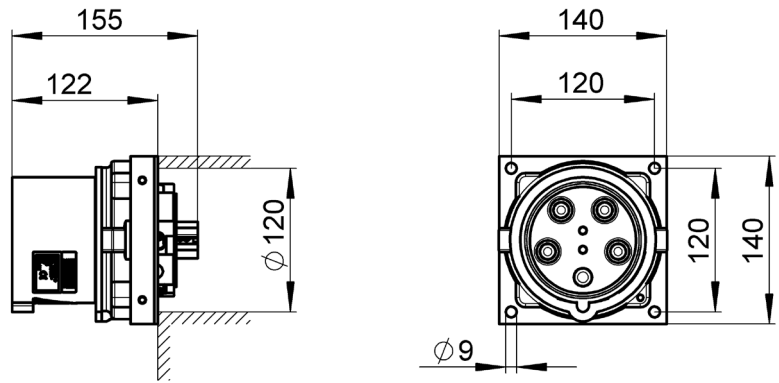

Current	No. of Poles	Voltage	Type designation	Article No.
160 A	4 (3L+PEN)	230V	MCP-S4/160 230V-9h	25160
		400V	MCP-S4/160 400V-6h	25161
		500V	MCP-S4/160 500V-7h	25162
		690V	MCP-S4/160 690V-5h	25163
		1000V	MCP-S4/160 1000V-1h	25164
	5 (3L+N+PE)	230V	MCP-S5/160 230V-9h	25170
		400V	MCP-S5/160 400V-6h	25171
		500V	MCP-S5/160 500V-7h	25172
		690V	MCP-S5/160 690V-5h	25173
		1000V	MCP-S5/160 1000V-1h	25174

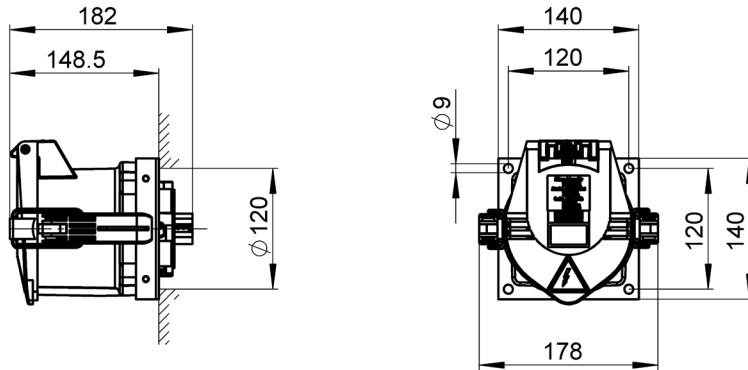

Current	No. of Poles	Voltage	Type designation	Article No.
160 A	4 (3L+PEN)	230V	FCP-S4/160 230V-9h	25165
		400V	FCP-S4/160 400V-6h	25166
		500V	FCP-S4/160 500V-7h	25167
		690V	FCP-S4/160 690V-5h	25168
		1000V	FCP-S4/160 1000V-1h	25169
	5 (3L+N+PE)	230V	FCP-S5/160 230V-9h	25175
		400V	FCP-S5/160 400V-6h	25176
		500V	FCP-S5/160 500V-7h	25177
		690V	FCP-S5/160 690V-5h	25178
		1000V	FCP-S5/160 1000V-1h	25179



MCPA

Panel Mounted Inlet Angled

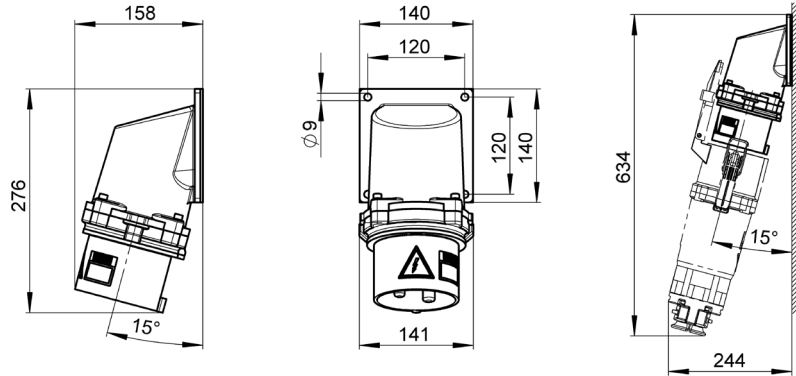

Current	No. of Poles	Voltage	Type designation	Article No.
160 A	4 (3L+PEN)	230V	MCPA-S4/160 230V-9h	25180
		400V	MCPA-S4/160 400V-6h	25181
		500V	MCPA-S4/160 500V-7h	25182
		690V	MCPA-S4/160 690V-5h	25183
		1000V	MCPA-S4/160 1000V-1h	25184
	5 (3L+N+PE)	230V	MCPA-S5/160 230V-9h	25190
		400V	MCPA-S5/160 400V-6h	25191
		500V	MCPA-S5/160 500V-7h	25192
		690V	MCPA-S5/160 690V-5h	25193
		1000V	MCPA-S5/160 1000V-1h	25194

FCPA

Panel Mounted Receptacle Angled

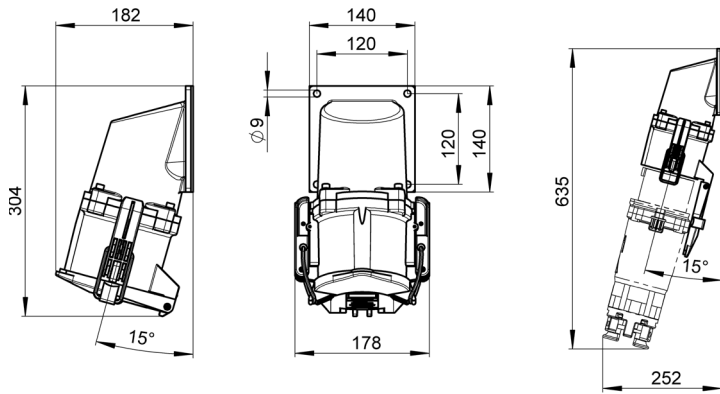

Current	No. of Poles	Voltage	Type designation	Article No.
160 A	4 (3L+PEN)	230V	FCPA-S4/160 230V-9h	25185
		400V	FCPA-S4/160 400V-6h	25186
		500V	FCPA-S4/160 500V-7h	25187
		690V	FCPA-S4/160 690V-5h	25188
		1000V	FCPA-S4/160 1000V-1h	25189
	5 (3L+N+PE)	230V	FCPA-S5/160 230V-9h	25195
		400V	FCPA-S5/160 400V-6h	25196
		500V	FCPA-S5/160 500V-7h	25197
		690V	FCPA-S5/160 690V-5h	25198
		1000V	FCPA-S5/160 1000V-1h	25199



Options

Accessories for every requirement



Seawater resistant connector

For port applications, an option often requested by the customer. The seawater-resistant design prevents oxidation on the housing.

Seawater resistant connectors upon request.



Vibration resistant connectors

On request there are vibration resistant connectors available. This option is frequently asked for railway applications.



Accessories:

- Protective cover (article number: 12122)
- Screwed cable gland for separate pilot cable (article number 13642)
- Padlock (article number: 14349)

General information

Plastic housing D-Line

The D-Line connectors have a special plastic housing. This housing has special properties for applications and is resistant to many chemicals (see table).

- High thermal stability
- Very good insulating properties
- High dielectric strength
- Resistance to many different chemicals
- Compliant with RoHS Directive 2011/65 / EU
- High impact strength and resistance

Plastic housing characteristics

Chemicals	Resistant	Not resistant
Acetic acid	X	
Citric acid solution	X	
Lactic acid	X	
Hydrochloric acid		X
Nitric acid		X
Sulfuric acid		X
Chromic Acid Solution		X
Sodium hydroxide solution	X	
Isopropanol	X	
Methanol	X	
Ethanol	X	
Hydrogen peroxide		X

Chemicals	Resistant	Not resistant
N-hexane	X	
Toluene	X	
Iso-octane	X	
Acetone	X	
Diethyl ether	X	
SAE10W40 Multi-range oil	X	
Diesel oil	X	
Sodium hypochlorite solution		X
Zinc chloride solution		X
Ethyl acetate	X	
Ethylene glycol		X
Water	X	

Weight and packaging-information

Article		Weight (kg)	Packaging Bulk outside (mm)
Plug MC	4-polig	2.7	405 x 190 x 185
	5-polig	2.9	405 x 190 x 185
Panel Mounted Inlet MCP	4-polig	2.2	286 x 204 x 140
	5-polig	2.4	286 x 204 x 140
Panel Mounted Inlet Angled MCPA	4-polig	4.2	462 x 240 x 242
	5-polig	4.4	462 x 240 x 242
Wall Mounted Inlet MCW	4-polig	3.6	360 x 240 x 200
	5-polig	3.8	360 x 240 x 200
Coupling FC	4-polig	3.4	405 x 190 x 185
	5-polig	3.6	405 x 190 x 185
Panel Mounted Receptacle FCP	4-polig	3.2	405 x 190 x 185
	5-polig	3.5	405 x 190 x 185
Panel Mounted Receptacle Angled FCPA	4-polig	4.4	462 x 240 x 242
	5-polig	4.6	462 x 240 x 242
Wall Mounted Receptacle FCW	4-polig	4.3	360 x 240 x 200
	5-polig	4.5	360 x 240 x 200

C - Line

Technical Data



Technical Data	Unit	C - Line	
Nominal current	A	200	250
Rated current	A	250	285
Rated voltage	V	1.000	
Rated frequency	Hz	50 / 60	
Withstand voltage (1 Min / 50 Hz)	V	4.000	
Protection grade		IP 67	
Shock resistance		IK 10	
Ambient temperature	°C	- 40 / + 100	
Insulation resistance (Phase-phase and phase-earth)	MOhm	> 500	
Comparative tracking index of the insert	CTI	> 600	
Terminal cross-section (EN 60228 Class 5)	mm ²	35 - 150	
Max. cross section pilot cable, conductor (EN60228 Class 5)	mm ²	4	
Diameter of cable	mm	34 - 66	
Diameter of cable - separate pilot cable	mm	5 - 10	

Technical modifications reserved

Structure

Structure of C-Line connector

- 1.Cable gland
- 2.Plastic housing
- 3.Connector insert
- 4.Connector collar

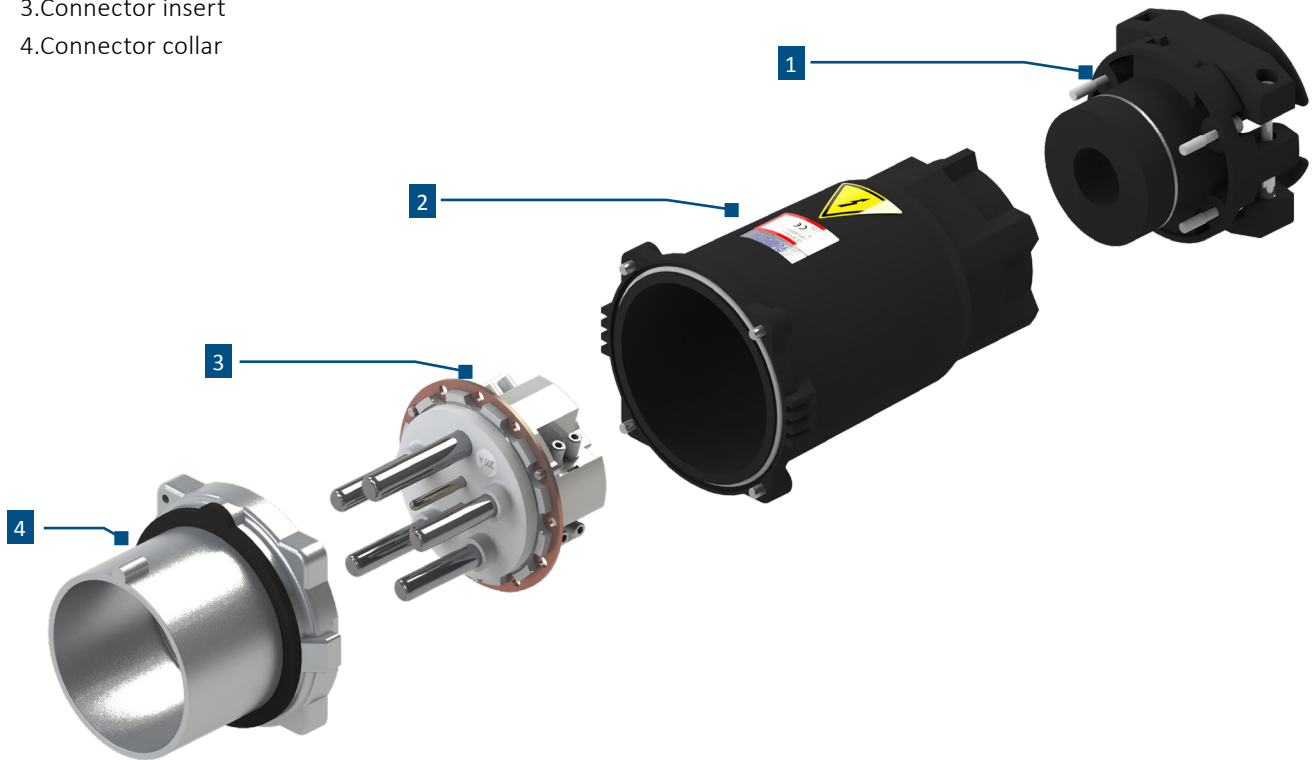

Locking system

Mechanically easy designed locking system, which reduces the force required during plugging and pulling.

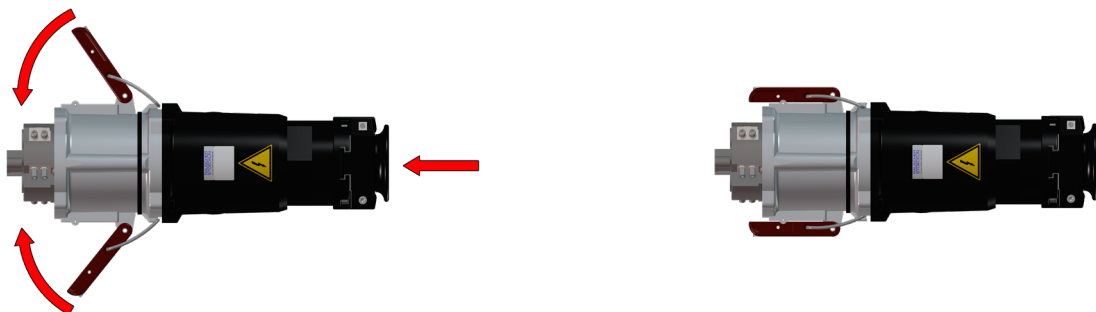

MC

Plug

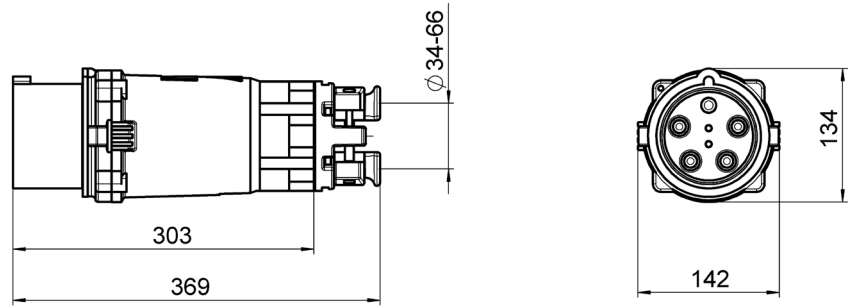

Current	Number of Poles	Voltage	Type designation	Article No.
200 A	4 (3L+PEN)	230V	MC-S4/200 230V-9h	11430
		400V	MC-S4/200 400V-6h	11431
		500V	MC-S4/200 500V-7h	11432
		690V	MC-S4/200 690V-5h	11433
		1000V	MC-S4/200 1000V-1h	11434
	5 (3L+N+PE)	230V	MC-S5/200 230V-9h	11435
		400V	MC-S5/200 400V-6h	11436
		500V	MC-S5/200 500V-7h	11437
		690V	MC-S5/200 690V-5h	11438
		1000V	MC-S5/200 1000V-1h	11439
250 A	4 (3L+PEN)	230V	MC-S4/250 230V-9h	22080
		400V	MC-S4/250 400V-6h	22081
		500V	MC-S4/250 500V-7h	22082
		690V	MC-S4/250 690V-5h	22083
		1000V	MC-S4/250 1000V-1h	22084
	5 (3L+N+PE)	230V	MC-S5/250 230V-9h	22085
		400V	MC-S5/250 400V-6h	22086
		500V	MC-S5/250 500V-7h	22087
		690V	MC-S5/250 690V-5h	22088
		1000V	MC-S5/250 1000V-1h	22089

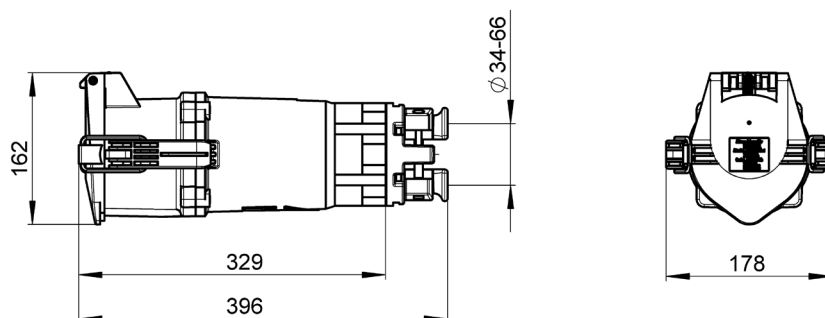

Current	Number of Poles	Voltage	Type designation	Article No.
200 A	4 (3L+PEN)	230V	FC-S4/200 230V-9h	11640
		400V	FC-S4/200 400V-6h	11641
		500V	FC-S4/200 500V-7h	11642
		690V	FC-S4/200 690V-5h	11643
		1000V	FC-S4/200 1000V-1h	11644
	5 (3L+N+PE)	230V	FC-S5/200 230V-9h	11645
		400V	FC-S5/200 400V-6h	11646
		500V	FC-S5/200 500V-7h	11647
		690V	FC-S5/200 690V-5h	11648
		1000V	FC-S5/200 1000V-1h	11649
250 A	4 (3L+PEN)	230V	FC-S4/250 230V-9h	22120
		400V	FC-S4/250 400V-6h	22121
		500V	FC-S4/250 500V-7h	22122
		690V	FC-S4/250 690V-5h	22123
		1000V	FC-S4/250 1000V-1h	22124
	5 (3L+N+PE)	230V	FC-S5/250 230V-9h	22125
		400V	FC-S5/250 400V-6h	22126
		500V	FC-S5/250 500V-7h	22127
		690V	FC-S5/250 690V-5h	22128
		1000V	FC-S5/250 1000V-1h	22129



MCW

Wall Mounted Inlet

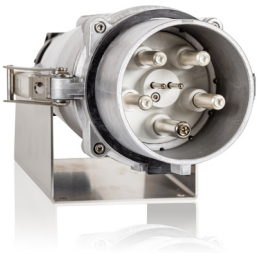
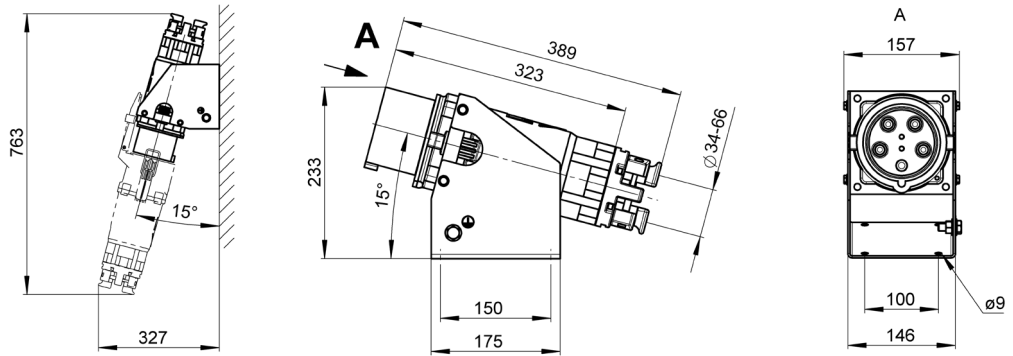

Current	Number of Poles	Voltage	Type designation	Article No.
200 A	4 (3L+PEN)	230V	MCW-S4/200 230V-9h	11700
		400V	MCW-S4/200 400V-6h	11701
		500V	MCW-S4/200 500V-7h	11702
		690V	MCW-S4/200 690V-5h	11703
		1000V	MCW-S4/200 1000V-1h	11704
	5 (3L+N+PE)	230V	MCW-S5/200 230V-9h	11705
		400V	MCW-S5/200 400V-6h	11706
		500V	MCW-S5/200 500V-7h	11707
		690V	MCW-S5/200 690V-5h	11708
		1000V	MCW-S5/200 1000V-1h	11709
250 A	4 (3L+PEN)	230V	MCW-S4/250 230V-9h	22110
		400V	MCW-S4/250 400V-6h	22111
		500V	MCW-S4/250 500V-7h	22112
		690V	MCW-S4/250 690V-5h	22113
		1000V	MCW-S4/250 1000V-1h	22114
	5 (3L+N+PE)	230V	MCW-S5/250 230V-9h	22115
		400V	MCW-S5/250 400V-6h	22116
		500V	MCW-S5/250 500V-7h	22117
		690V	MCW-S5/250 690V-5h	22118
		1000V	MCW-S5/250 1000V-1h	22119

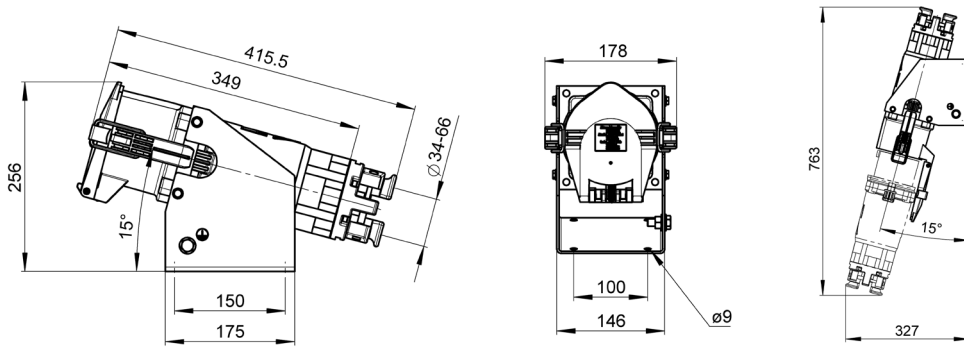

Current	Number of Poles	Voltage	Type designation	Article No.
200 A	4 (3L+PEN)	230V	FCW-S4/200 230V-9h	11670
		400V	FCW-S4/200 400V-6h	11671
		500V	FCW-S4/200 500V-7h	11672
		690V	FCW-S4/200 690V-5h	11673
		1000V	FCW-S4/200 1000V-1h	11674
	5 (3L+N+PE)	230V	FCW-S5/200 230V-9h	11675
		400V	FCW-S5/200 400V-6h	11676
		500V	FCW-S5/200 500V-7h	11677
		690V	FCW-S5/200 690V-5h	11678
		1000V	FCW-S5/200 1000V-1h	11679
250 A	4 (3L+PEN)	230V	FCW-S4/250 230V-9h	22150
		400V	FCW-S4/250 400V-6h	22151
		500V	FCW-S4/250 500V-7h	22152
		690V	FCW-S4/250 690V-5h	22153
		1000V	FCW-S4/250 1000V-1h	22154
	5 (3L+N+PE)	230V	FCW-S5/250 230V-9h	22155
		400V	FCW-S5/250 400V-6h	22156
		500V	FCW-S5/250 500V-7h	22157
		690V	FCW-S5/250 690V-5h	22158
		1000V	FCW-S5/250 1000V-1h	22159

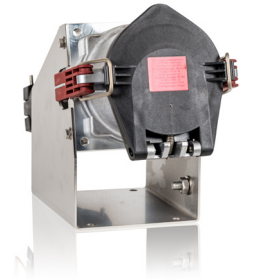

MCP

Panel Mounted Inlet

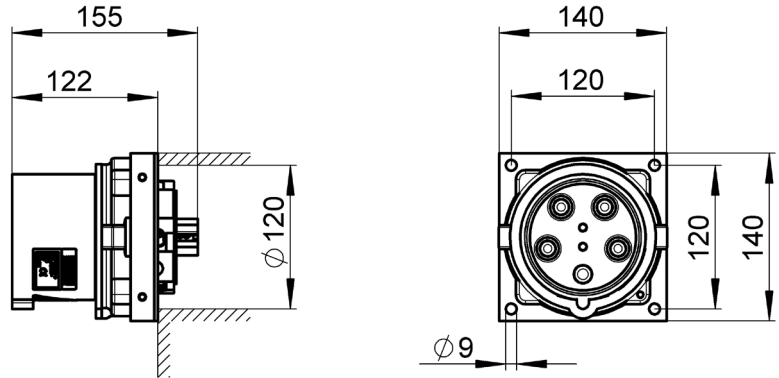

Current	Number of Poles	Voltage	Type designation	Article No.
200 A	4 (3L+PEN)	230V	MCP-S4/200 230V-9h	11730
		400V	MCP-S4/200 400V-6h	11731
		500V	MCP-S4/200 500V-7h	11732
		690V	MCP-S4/200 690V-5h	11733
		1000V	MCP-S4/200 1000V-1h	11734
	5 (3L+N+PE)	230V	MCP-S5/200 230V-9h	11735
		400V	MCP-S5/200 400V-6h	11736
		500V	MCP-S5/200 500V-7h	11737
		690V	MCP-S5/200 690V-5h	11738
		1000V	MCP-S5/200 1000V-1h	11739
250 A	4 (3L+PEN)	230V	MCP-S4/250 230V-9h	22090
		400V	MCP-S4/250 400V-6h	22091
		500V	MCP-S4/250 500V-7h	22092
		690V	MCP-S4/250 690V-5h	22093
		1000V	MCP-S4/250 1000V-1h	22094
	5 (3L+N+PE)	230V	MCP-S5/250 230V-9h	22095
		400V	MCP-S5/250 400V-6h	22096
		500V	MCP-S5/250 500V-7h	22097
		690V	MCP-S5/250 690V-5h	22098
		1000V	MCP-S5/250 1000V-1h	22099

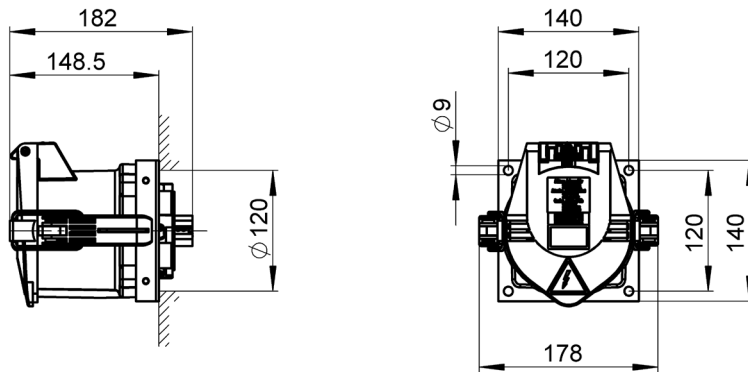

Current	Number of Poles	Voltage	Type designation	Article No.
200 A	4 (3L+PEN)	230V	FCP-S4/200 230V-9h	11760
		400V	FCP-S4/200 400V-6h	11761
		500V	FCP-S4/200 500V-7h	11762
		690V	FCP-S4/200 690V-5h	11763
		1000V	FCP-S4/200 1000V-1h	11764
	5 (3L+N+PE)	230V	FCP-S5/200 230V-9h	11765
		400V	FCP-S5/200 400V-6h	11766
		500V	FCP-S5/200 500V-7h	11767
		690V	FCP-S5/200 690V-5h	11768
		1000V	FCP-S5/200 1000V-1h	11769
250 A	4 (3L+PEN)	230V	FCP-S4/250 230V-9h	22130
		400V	FCP-S4/250 400V-6h	22131
		500V	FCP-S4/250 500V-7h	22132
		690V	FCP-S4/250 690V-5h	22133
		1000V	FCP-S4/250 1000V-1h	22134
	5 (3L+N+PE)	230V	FCP-S5/250 230V-9h	22135
		400V	FCP-S5/250 400V-6h	22136
		500V	FCP-S5/250 500V-7h	22137
		690V	FCP-S5/250 690V-5h	22138
		1000V	FCP-S5/250 1000V-1h	22139



MCPA

Panel Mounted Inlet Angled

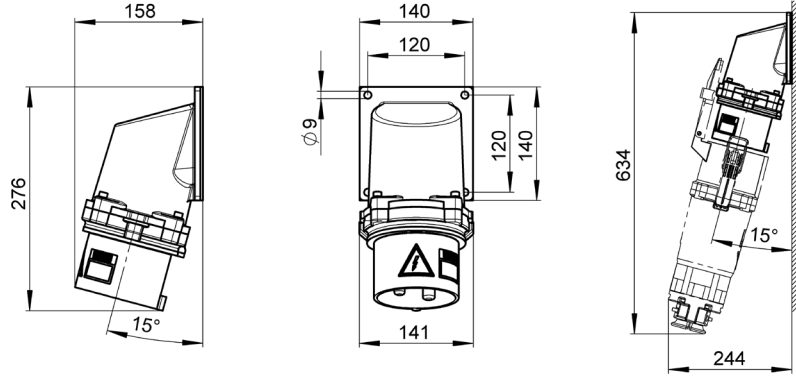

Current	Number of Poles	Voltage	Type designation	Article No.
200 A	4 (3L+PEN)	230V	MCPA-S4/200 230V-9h	20578
		400V	MCPA-S4/200 400V-6h	20579
		500V	MCPA-S4/200 500V-7h	20580
		690V	MCPA-S4/200 690V-5h	20581
		1000V	MCPA-S4/200 1000V-1h	20582
	5 (3L+N+PE)	230V	MCPA-S5/200 230V-9h	20583
		400V	MCPA-S5/200 400V-6h	20584
		500V	MCPA-S5/200 500V-7h	20585
		690V	MCPA-S5/200 690V-5h	20586
		1000V	MCPA-S5/200 1000V-1h	20587
250 A	4 (3L+PEN)	230V	MCPA-S4/250 230V-9h	22100
		400V	MCPA-S4/250 400V-6h	22101
		500V	MCPA-S4/250 500V-7h	22102
		690V	MCPA-S4/250 690V-5h	22103
		1000V	MCPA-S4/250 1000V-1h	22104
	5 (3L+N+PE)	230V	MCPA-S5/250 230V-9h	22105
		400V	MCPA-S5/250 400V-6h	22106
		500V	MCPA-S5/250 500V-7h	22107
		690V	MCPA-S5/250 690V-5h	22108
		1000V	MCPA-S5/250 1000V-1h	22109

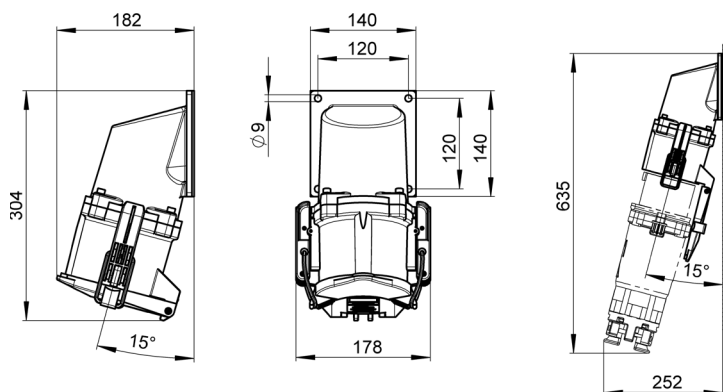

Current	Number of Poles	Voltage	Type designation	Article No.
200 A	4 (3L+PEN)	230V	FCPA-S4/200 230V-9h	20608
		400V	FCPA-S4/200 400V-6h	20609
		500V	FCPA-S4/200 500V-7h	20610
		690V	FCPA-S4/200 690V-5h	20611
		1000V	FCPA-S4/200 1000V-1h	20612
	5 (3L+N+PE)	230V	FCPA-S5/200 230V-9h	20613
		400V	FCPA-S5/200 400V-6h	20614
		500V	FCPA-S5/200 500V-7h	20615
		690V	FCPA-S5/200 690V-5h	20616
		1000V	FCPA-S5/200 1000V-1h	20617
250 A	4 (3L+PEN)	230V	FCPA-S4/250 230V-9h	22140
		400V	FCPA-S4/250 400V-6h	22141
		500V	FCPA-S4/250 500V-7h	22142
		690V	FCPA-S4/250 690V-5h	22143
		1000V	FCPA-S4/250 1000V-1h	22144
	5 (3L+N+PE)	230V	FCPA-S5/250 230V-9h	22145
		400V	FCPA-S5/250 400V-6h	22146
		500V	FCPA-S5/250 500V-7h	22147
		690V	FCPA-S5/250 690V-5h	22148
		1000V	FCPA-S5/250 1000V-1h	22149



Options

Accessories for every requirement



Seawater resistant connector

For port applications, an option often requested by the customer. The seawater-resistant design prevents oxidation on the housing.

Seawater resistant connectors upon request.



Vibration resistant connectors

On request there are vibration resistant connectors available. This option is frequently asked for railway applications.



Accessories:

- Protective cover (article number: 12122)
- Screwed cable gland for separate pilot cable (article number 13642)
- Padlock (article number: 14349)

General information

Plastic housing C-Line

The C-Line connectors have a special plastic housing.

This housing has special properties for applications and is resistant to many chemicals (see table).

- High thermal stability
- Very good insulating properties
- High dielectric strength
- Resistance to many different chemicals
- Compliant with RoHS Directive 2011/65 / EU
- High impact strength and resistance

Plastic housing characteristics

Chemicals	Resistant	Not resistant
Acetic acid	X	
Citric acid solution	X	
Lactic acid	X	
Hydrochloric acid		X
Nitric acid		X
Sulfuric acid		X
Chromic Acid Solution		X
Sodium hydroxide solution	X	
Isopropanol	X	
Methanol	X	
Ethanol	X	
Hydrogen peroxide		X

Chemicals	Resistant	Not resistant
N-hexane	X	
Toluene	X	
Iso-octane	X	
Acetone	X	
Diethyl ether	X	
SAE10W40 Multi-range oil	X	
Diesel oil	X	
Sodium hypochlorite solution		X
Zinc chloride solution		X
Ethyl acetate	X	
Ethylene glycol		X
Water	X	

Weight and packaging-information

Article		Weight (kg)	Packaging Bulk outside (mm)
Plug MC	4-polig	2.7	405 x 190 x 185
	5-polig	2.9	405 x 190 x 185
Panel Mounted Inlet MCP	4-polig	2.2	286 x 204 x 140
	5-polig	2.4	286 x 204 x 140
Panel Mounted Inlet Angled MCPA	4-polig	4.2	462 x 240 x 242
	5-polig	4.4	462 x 240 x 242
Wall Mounted Inlet MCW	4-polig	3.6	360 x 240 x 200
	5-polig	3.8	360 x 240 x 200
Coupling FC	4-polig	3.4	405 x 190 x 185
	5-polig	3.6	405 x 190 x 185
Panel Mounted Receptacle FCP	4-polig	3.2	405 x 190 x 185
	5-polig	3.5	405 x 190 x 185
Panel Mounted Receptacle Angled FCPA	4-polig	4.4	462 x 240 x 242
	5-polig	4.6	462 x 240 x 242
Wall Mounted Receptacle FCW	4-polig	4.3	360 x 240 x 200
	5-polig	4.5	360 x 240 x 200

B - Line

Technical Data



Technical Data	Unit	B - Line		
Nominal current	A	250	315	400
Rated current	A	315	380	450
Rated voltage	V	1'000		
Rated frequency	Hz	50 / 60		
Withstand voltage (1 Min / 50 Hz)	V	4'000		
Protection grade		IP 67		
Shock resistance		IK 10		
Ambient temperature	°C	-40 / +100		
Insulation resistance (Phase-phase and phase-earth)	MOhm	> 500		
Comparative tracking index of the insert	CTI	> 600		
Terminal cross-section (EN 60228 Class 5)	mm ²	70 - 240		
Max. cross section pilot cable, conductor (EN60228 Class 5)	mm ²	4		
Diameter of cable	mm	34 - 66 until 80 on request		
Diameter of cable - separate pilot cable	mm	8 -15		

Technical modifications reserved

Structure

Structure of C-Line connector

- 1.Cable gland
- 2.Aluminum housing
- 3.Connector insert
- 4.Connector collar

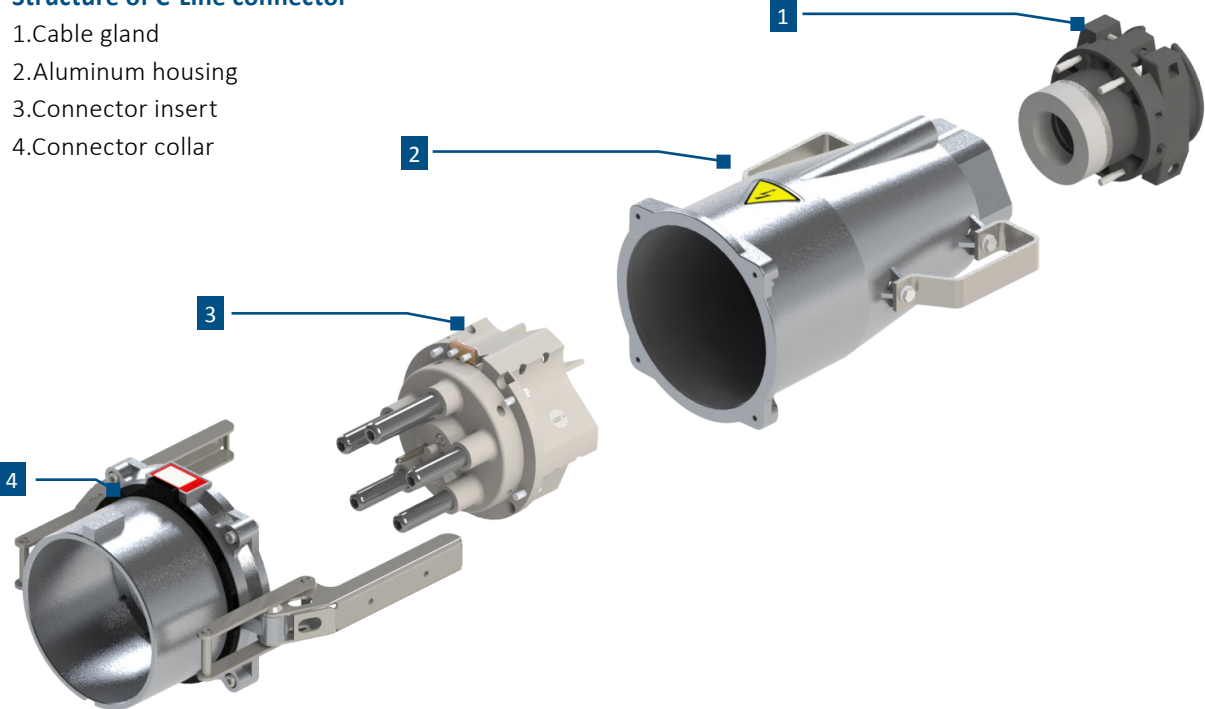

Locking system

Mechanically easy designed locking system, which reduces the force required during plugging and pulling.

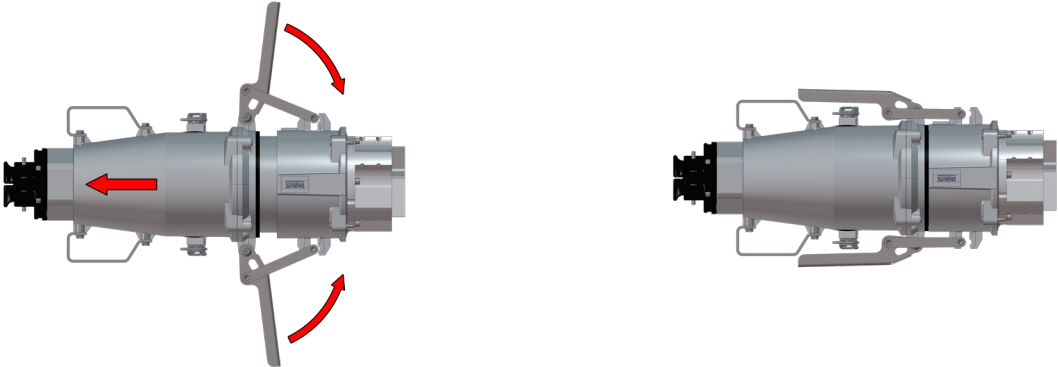

MC

Plug

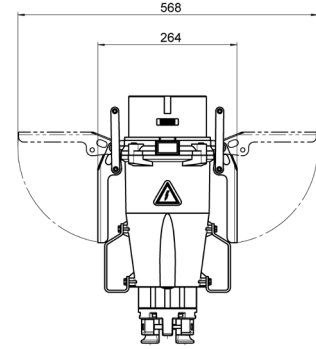
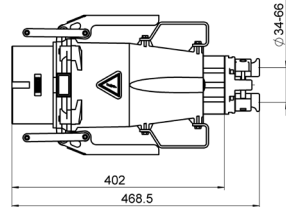

Current	Number of Poles	Voltage	Type designation	Article No.
250A	4 (3L+PEN)	230V	MC-S4/250 230V-9h	11440
		400V	MC-S4/250 400V-6h	11441
		500V	MC-S4/250 500V-7h	11442
		690V	MC-S4/250 690V-5h	11443
		1000V	MC-S4/250 1000V-1h	11444
	5 (3L+N+PE)	230V	MC-S5/250 230V-9h	11445
		400V	MC-S5/250 400V-6h	11446
		500V	MC-S5/250 500V-7h	11447
		690V	MC-S5/250 690V-5h	11448
		1000V	MC-S5/250 1000V-1h	11449
315 A	4 (3L+PEN)	230V	MC-S4/315 230V-9h	22900
		400V	MC-S4/315 400V-6h	22901
		500V	MC-S4/315 500V-7h	22902
		690V	MC-S4/315 690V-5h	22903
		1000V	MC-S4/315 1000V-1h	22904
	5 (3L+N+PE)	230V	MC-S5/315 230V-9h	22905
		400V	MC-S5/315 400V-6h	22906
		500V	MC-S5/315 500V-7h	22907
		690V	MC-S5/315 690V-5h	22908
		1000V	MC-S5/315 1000V-1h	22909
400 A	4 (3L+PEN)	230V	MC-S4/400 230V-9h	11450
		400V	MC-S4/400 400V-6h	11451
		500V	MC-S4/400 500V-7h	11452
		690V	MC-S4/400 690V-5h	11453
		1000V	MC-S4/400 1000V-1h	11454
	5 (3L+N+PE)	230V	MC-S5/400 230V-9h	11455
		400V	MC-S5/400 400V-6h	11456
		500V	MC-S5/400 500V-7h	11457
		690V	MC-S5/400 690V-5h	11458
		1000V	MC-S5/400 1000V-1h	11459

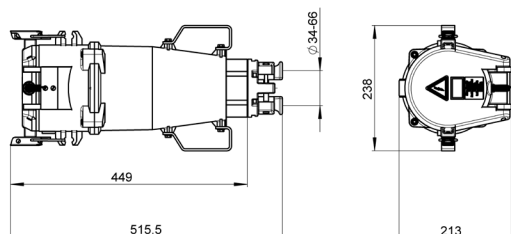

Current	Number of Poles	Voltage	Type designation	Article No.
250A	4 (3L+PEN)	230V	FC-S4/250 230V-9h	11650
		400V	FC-S4/250 400V-6h	11651
		500V	FC-S4/250 500V-7h	11652
		690V	FC-S4/250 690V-5h	11653
		1000V	FC-S4/250 1000V-1h	11654
	5 (3L+N+PE)	230V	FC-S5/250 230V-9h	11655
		400V	FC-S5/250 400V-6h	11656
		500V	FC-S5/250 500V-7h	11657
		690V	FC-S5/250 690V-5h	11658
		1000V	FC-S5/250 1000V-1h	11659
315 A	4 (3L+PEN)	230V	FC-S4/315 230V-9h	22890
		400V	FC-S4/315 400V-6h	22891
		500V	FC-S4/315 500V-7h	22892
		690V	FC-S4/315 690V-5h	22893
		1000V	FC-S4/315 1000V-1h	22894
	5 (3L+N+PE)	230V	FC-S5/315 230V-9h	22895
		400V	FC-S5/315 400V-6h	22896
		500V	FC-S5/315 500V-7h	22897
		690V	FC-S5/315 690V-5h	22898
		1000V	FC-S5/315 1000V-1h	22899
400 A	4 (3L+PEN)	230V	FC-S4/400 230V-9h	11660
		400V	FC-S4/400 400V-6h	11661
		500V	FC-S4/400 500V-7h	11662
		690V	FC-S4/400 690V-5h	11663
		1000V	FC-S4/400 1000V-1h	11664
	5 (3L+N+PE)	230V	FC-S5/400 230V-9h	11665
		400V	FC-S5/400 400V-6h	11666
		500V	FC-S5/400 500V-7h	11667
		690V	FC-S5/400 690V-5h	11668
		1000V	FC-S5/400 1000V-1h	11669



MCW

Wall Mounted Inlet

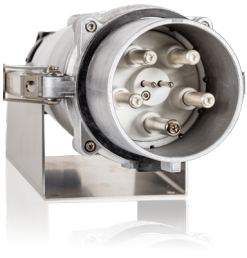
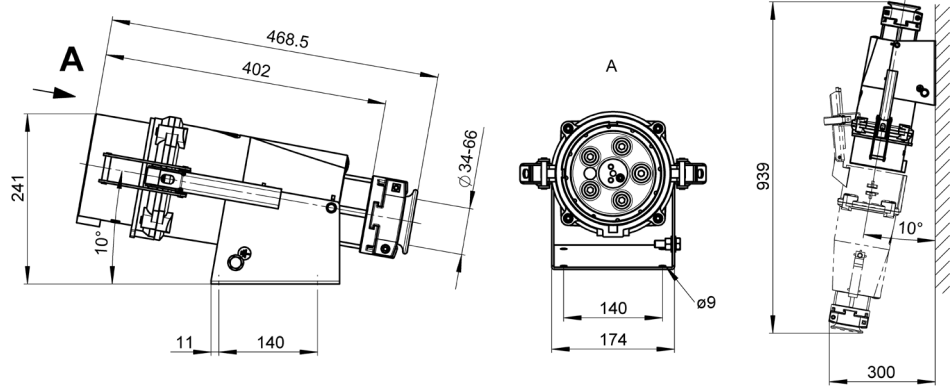

Current	Number of Poles	Voltage	Type designation	Article No.
250A	4 (3L+PEN)	230V	MCW-S4/250 230V-9h	11710
		400V	MCW-S4/250 400V-6h	11711
		500V	MCW-S4/250 500V-7h	11712
		690V	MCW-S4/250 690V-5h	11713
		1000V	MCW-S4/250 1000V-1h	11714
	5 (3L+N+PE)	230V	MCW-S5/250 230V-9h	11715
		400V	MCW-S5/250 400V-6h	11716
		500V	MCW-S5/250 500V-7h	11717
		690V	MCW-S5/250 690V-5h	11718
		1000V	MCW-S5/250 1000V-1h	11719
315 A	4 (3L+PEN)	230V	MCW-S4/315 230V-9h	22910
		400V	MCW-S4/315 400V-6h	22911
		500V	MCW-S4/315 500V-7h	22912
		690V	MCW-S4/315 690V-5h	22913
		1000V	MCW-S4/315 1000V-1h	22914
	5 (3L+N+PE)	230V	MCW-S5/315 230V-9h	22915
		400V	MCW-S5/315 400V-6h	22916
		500V	MCW-S5/315 500V-7h	22917
		690V	MCW-S5/315 690V-5h	22918
		1000V	MCW-S5/315 1000V-1h	22919
400 A	4 (3L+PEN)	230V	MCW-S4/400 230V-9h	11720
		400V	MCW-S4/400 400V-6h	11721
		500V	MCW-S4/400 500V-7h	11722
		690V	MCW-S4/400 690V-5h	11723
		1000V	MCW-S4/400 1000V-1h	11724
	5 (3L+N+PE)	230V	MCW-S5/400 230V-9h	11725
		400V	MCW-S5/400 400V-6h	11726
		500V	MCW-S5/400 500V-7h	11727
		690V	MCW-S5/400 690V-5h	11728
		1000V	MCW-S5/400 1000V-1h	11729

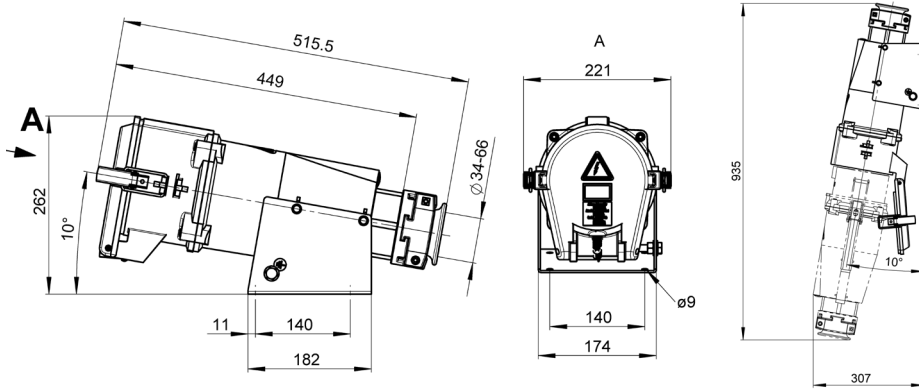

Current	Number of Poles	Voltage	Type designation	Article No.
250A	4 (3L+PEN)	230V	FCW-S4/250 230V-9h	11680
		400V	FCW-S4/250 400V-6h	11681
		500V	FCW-S4/250 500V-7h	11682
		690V	FCW-S4/250 690V-5h	11683
		1000V	FCW-S4/250 1000V-1h	11684
	5 (3L+N+PE)	230V	FCW-S5/250 230V-9h	11685
		400V	FCW-S5/250 400V-6h	11686
		500V	FCW-S5/250 500V-7h	11687
		690V	FCW-S5/250 690V-5h	11688
		1000V	FCW-S5/250 1000V-1h	11689
315 A	4 (3L+PEN)	230V	FCW-S4/315 230V-9h	22860
		400V	FCW-S4/315 400V-6h	22861
		500V	FCW-S4/315 500V-7h	22862
		690V	FCW-S4/315 690V-5h	22863
		1000V	FCW-S4/315 1000V-1h	22864
	5 (3L+N+PE)	230V	FCW-S5/315 230V-9h	22865
		400V	FCW-S5/315 400V-6h	22866
		500V	FCW-S5/315 500V-7h	22867
		690V	FCW-S5/315 690V-5h	22868
		1000V	FCW-S5/315 1000V-1h	22869
400 A	4 (3L+PEN)	230V	FCW-S4/400 230V-9h	11690
		400V	FCW-S4/400 400V-6h	11691
		500V	FCW-S4/400 500V-7h	11692
		690V	FCW-S4/400 690V-5h	11693
		1000V	FCW-S4/400 1000V-1h	11694
	5 (3L+N+PE)	230V	FCW-S5/400 230V-9h	11695
		400V	FCW-S5/400 400V-6h	11696
		500V	FCW-S5/400 500V-7h	11697
		690V	FCW-S5/400 690V-5h	11698
		1000V	FCW-S5/400 1000V-1h	11699



MCP

Panel Mounted Inlet

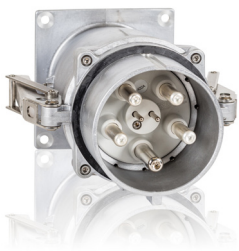
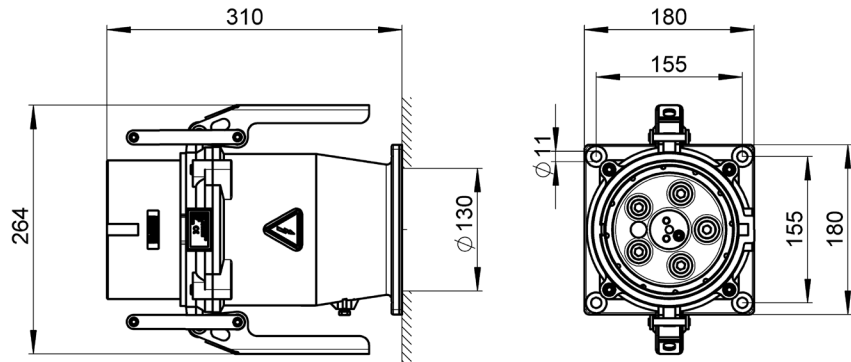

Current	Number of Poles	Voltage	Type designation	Article No.
250A	4 (3L+PEN)	230V	MCP-S4/250 230V-9h	11740
		400V	MCP-S4/250 400V-6h	11741
		500V	MCP-S4/250 500V-7h	11742
		690V	MCP-S4/250 690V-5h	11743
		1000V	MCP-S4/250 1000V-1h	11744
	5 (3L+N+PE)	230V	MCP-S5/250 230V-9h	11745
		400V	MCP-S5/250 400V-6h	11746
		500V	MCP-S5/250 500V-7h	11747
		690V	MCP-S5/250 690V-5h	11748
		1000V	MCP-S5/250 1000V-1h	11749
315 A	4 (3L+PEN)	230V	MCP-S4/315 230V-9h	22920
		400V	MCP-S4/315 400V-6h	22921
		500V	MCP-S4/315 500V-7h	22922
		690V	MCP-S4/315 690V-5h	22923
		1000V	MCP-S4/315 1000V-1h	22924
	5 (3L+N+PE)	230V	MCP-S5/315 230V-9h	22925
		400V	MCP-S5/315 400V-6h	22926
		500V	MCP-S5/315 500V-7h	22927
		690V	MCP-S5/315 690V-5h	22928
		1000V	MCP-S5/315 1000V-1h	22929
400 A	4 (3L+PEN)	230V	MCP-S4/400 230V-9h	11750
		400V	MCP-S4/400 400V-6h	11751
		500V	MCP-S4/400 500V-7h	11752
		690V	MCP-S4/400 690V-5h	11753
		1000V	MCP-S4/400 1000V-1h	11754
	5 (3L+N+PE)	230V	MCP-S5/400 230V-9h	11755
		400V	MCP-S5/400 400V-6h	11756
		500V	MCP-S5/400 500V-7h	11757
		690V	MCP-S5/400 690V-5h	11758
		1000V	MCP-S5/400 1000V-1h	11759

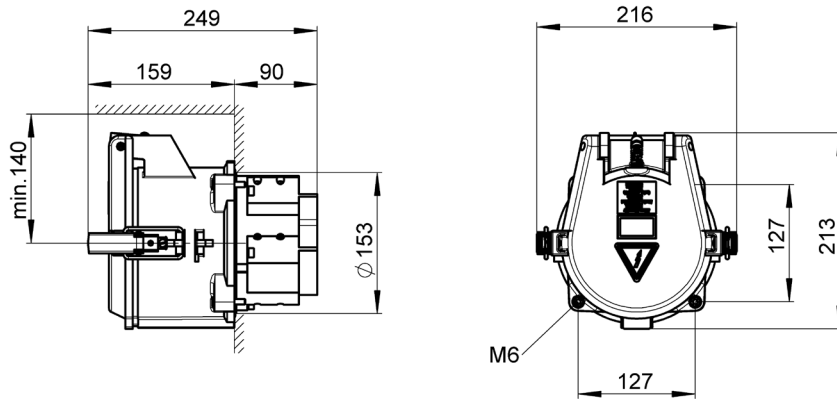

Current	Number of Poles	Voltage	Type designation	Article No.
250A	4 (3L+PEN)	230V	FCP-S4/250 230V-9h	11770
		400V	FCP-S4/250 400V-6h	11771
		500V	FCP-S4/250 500V-7h	11772
		690V	FCP-S4/250 690V-5h	11773
		1000V	FCP-S4/250 1000V-1h	11774
	5 (3L+N+PE)	230V	FCP-S5/250 230V-9h	11775
		400V	FCP-S5/250 400V-6h	11776
		500V	FCP-S5/250 500V-7h	11777
		690V	FCP-S5/250 690V-5h	11778
		1000V	FCP-S5/250 1000V-1h	11779
315 A	4 (3L+PEN)	230V	FCP-S4/315 230V-9h	22870
		400V	FCP-S4/315 400V-6h	22871
		500V	FCP-S4/315 500V-7h	22872
		690V	FCP-S4/315 690V-5h	22873
		1000V	FCP-S4/315 1000V-1h	22874
	5 (3L+N+PE)	230V	FCP-S5/315 230V-9h	22875
		400V	FCP-S5/315 400V-6h	22876
		500V	FCP-S5/315 500V-7h	22877
		690V	FCP-S5/315 690V-5h	22878
		1000V	FCP-S5/315 1000V-1h	22879
400 A	4 (3L+PEN)	230V	FCP-S4/400 230V-9h	11780
		400V	FCP-S4/400 400V-6h	11781
		500V	FCP-S4/400 500V-7h	11782
		690V	FCP-S4/400 690V-5h	11783
		1000V	FCP-S4/400 1000V-1h	11784
	5 (3L+N+PE)	230V	FCP-S5/400 230V-9h	11785
		400V	FCP-S5/400 400V-6h	11786
		500V	FCP-S5/400 500V-7h	11787
		690V	FCP-S5/400 690V-5h	11788
		1000V	FCP-S5/400 1000V-1h	11789



MCPA

Panel Mounted Inlet Angled

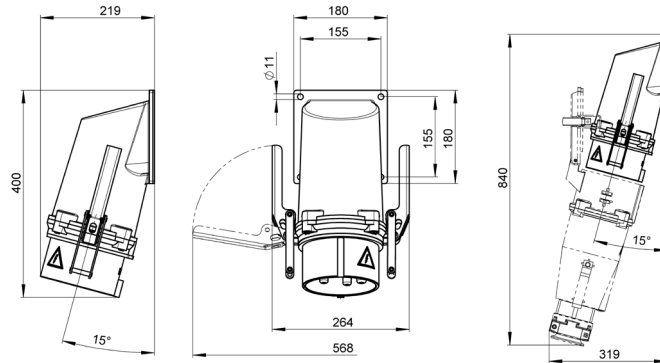

Current	Number of Poles	Voltage	Type designation	Article No.
250A	4 (3L+PEN)	230V	MCPA-S4/250 230V-9h	20588
		400V	MCPA-S4/250 400V-6h	20589
		500V	MCPA-S4/250 500V-7h	20590
		690V	MCPA-S4/250 690V-5h	20591
		1000V	MCPA-S4/250 1000V-1h	20592
	5 (3L+N+PE)	230V	MCPA-S5/250 230V-9h	20593
		400V	MCPA-S5/250 400V-6h	20594
		500V	MCPA-S5/250 500V-7h	20595
		690V	MCPA-S5/250 690V-5h	20596
		1000V	MCPA-S5/250 1000V-1h	20597
315 A	4 (3L+PEN)	230V	MCPA-S4/315 230V-9h	22930
		400V	MCPA-S4/315 400V-6h	22931
		500V	MCPA-S4/315 500V-7h	22932
		690V	MCPA-S4/315 690V-5h	22933
		1000V	MCPA-S4/315 1000V-1h	22934
	5 (3L+N+PE)	230V	MCPA-S5/315 230V-9h	22935
		400V	MCPA-S5/315 400V-6h	22936
		500V	MCPA-S5/315 500V-7h	22937
		690V	MCPA-S5/315 690V-5h	22938
		1000V	MCPA-S5/315 1000V-1h	22939
400 A	4 (3L+PEN)	230V	MCPA-S4/400 230V-9h	20598
		400V	MCPA-S4/400 400V-6h	20599
		500V	MCPA-S4/400 500V-7h	20600
		690V	MCPA-S4/400 690V-5h	20601
		1000V	MCPA-S4/400 1000V-1h	20602
	5 (3L+N+PE)	230V	MCPA-S5/400 230V-9h	20603
		400V	MCPA-S5/400 400V-6h	20604
		500V	MCPA-S5/400 500V-7h	20605
		690V	MCPA-S5/400 690V-5h	20606
		1000V	MCPA-S5/400 1000V-1h	20607

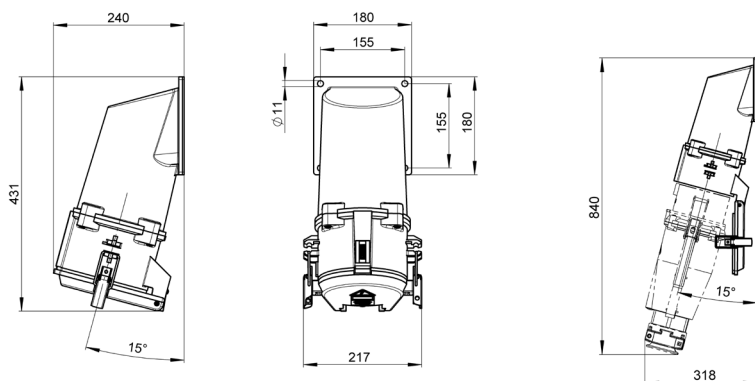

Current	Number of Poles	Voltage	Type designation	Article No.
250A	4 (3L+PEN)	230V	FCPA-S4/250 230V-9h	20618
		400V	FCPA-S4/250 400V-6h	20619
		500V	FCPA-S4/250 500V-7h	20620
		690V	FCPA-S4/250 690V-5h	20621
		1000V	FCPA-S4/250 1000V-1h	20622
	5 (3L+N+PE)	230V	FCPA-S5/250 230V-9h	20623
		400V	FCPA-S5/250 400V-6h	20624
		500V	FCPA-S5/250 500V-7h	20625
		690V	FCPA-S5/250 690V-5h	20626
		1000V	FCPA-S5/250 1000V-1h	20627
315 A	4 (3L+PEN)	230V	FCPA-S4/315 230V-9h	22880
		400V	FCPA-S4/315 400V-6h	22881
		500V	FCPA-S4/315 500V-7h	22882
		690V	FCPA-S4/315 690V-5h	22883
		1000V	FCPA-S4/315 1000V-1h	22884
	5 (3L+N+PE)	230V	FCPA-S5/315 230V-9h	22885
		400V	FCPA-S5/315 400V-6h	22886
		500V	FCPA-S5/315 500V-7h	22887
		690V	FCPA-S5/315 690V-5h	22888
		1000V	FCPA-S5/315 1000V-1h	22889
400 A	4 (3L+PEN)	230V	FCPA-S4/400 230V-9h	20628
		400V	FCPA-S4/400 400V-6h	20629
		500V	FCPA-S4/400 500V-7h	20630
		690V	FCPA-S4/400 690V-5h	20631
		1000V	FCPA-S4/400 1000V-1h	20632
	5 (3L+N+PE)	230V	FCPA-S5/400 230V-9h	20633
		400V	FCPA-S5/400 400V-6h	20634
		500V	FCPA-S5/400 500V-7h	20635
		690V	FCPA-S5/400 690V-5h	20636
		1000V	FCPA-S5/400 1000V-1h	20637



Options

Enhancements for every application



Seawater resistant connector

For port applications, an option often requested by the customer. The seawater-resistant design prevents oxidation on the housing.

Seawater resistant connectors upon request.

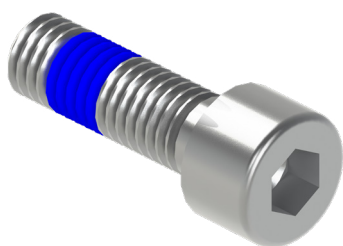

Vibration resistant connectors

On request there are vibration resistant connectors available. This option is frequently asked for railway applications.



Accessories:

- Cover cap (article No.: 12123)
- Cable gland up to \varnothing 80mm
 - 66 - 69.5mm - article No 12126
 - 68 - 74mm - article No: 12127
 - 74 - 80mm - article No: 22013
- Padlock (article Nor: 14349)

General information

Special features for B-Line connectors

Some product features listed in the catalog apply only to the B-Line connectors.

This includes:

- Exchangeable contacts
- Resistant housing up to 2 tons load

Weight and packaging-information

Article	Weight (kg)	Packaging Bulk outside (mm)
Plug MC	4-polig	462 x 240 x 242
	5-polig	462 x 240 x 242
Panel Mounted Inlet MCP	4-polig	275 x 230 x 350
	5-polig	275 x 230 x 350
Panel Mounted Inlet Angled MCPA	4-polig	462 x 240 x 242
	5-polig	462 x 240 x 242
Wall Mounted Inlet MCW	4-polig	462 x 240 x 242
	5-polig	462 x 240 x 242
Coupling FC	4-polig	462 x 240 x 242
	5-polig	462 x 240 x 242
Panel Mounted Receptacle FCP	4-polig	275 x 230 x 350
	5-polig	275 x 230 x 350
Panel Mounted Receptacle Angled FCPA	4-polig	462 x 240 x 242
	5-polig	462 x 240 x 242
Wall Mounted Receptacle FCW	4-polig	462 x 240 x 242
	5-polig	462 x 240 x 242

A - Line

Technical Data



Technical Data	Unit	A - Line	
Nominal current	A	500	600
Rated current	A	500	600
Rated voltage	V	1'000	
Rated frequency	Hz	50 / 60	
Withstand voltage (1 Min / 50 Hz)	V	4'000	
Protection grade		IP 67	
Shock resistance		IK 10	
Ambient temperature	°C	-40 / +100	
Insulation resistance (Phase-phase and phase-earth)	MOhm	> 500	
Comparative tracking index of the insert	CTI	> 600	
Terminal cross-section (EN 60228 Class 5)	mm ²	70 - 240	
Max. cross section pilot cable, conductor (EN 60228 Class 5)	mm ²	4	
Diameter of cable	mm	34 - 66 until 80 on request	
Diameter of cable - separate pilot cable	mm	8 -15	

Technical modifications reserved

Structure

Structure of A-Line Connector

- 1. Cable gland
- 2. Aluminium housing
- 3. Connector insert
- 4. Connector collar

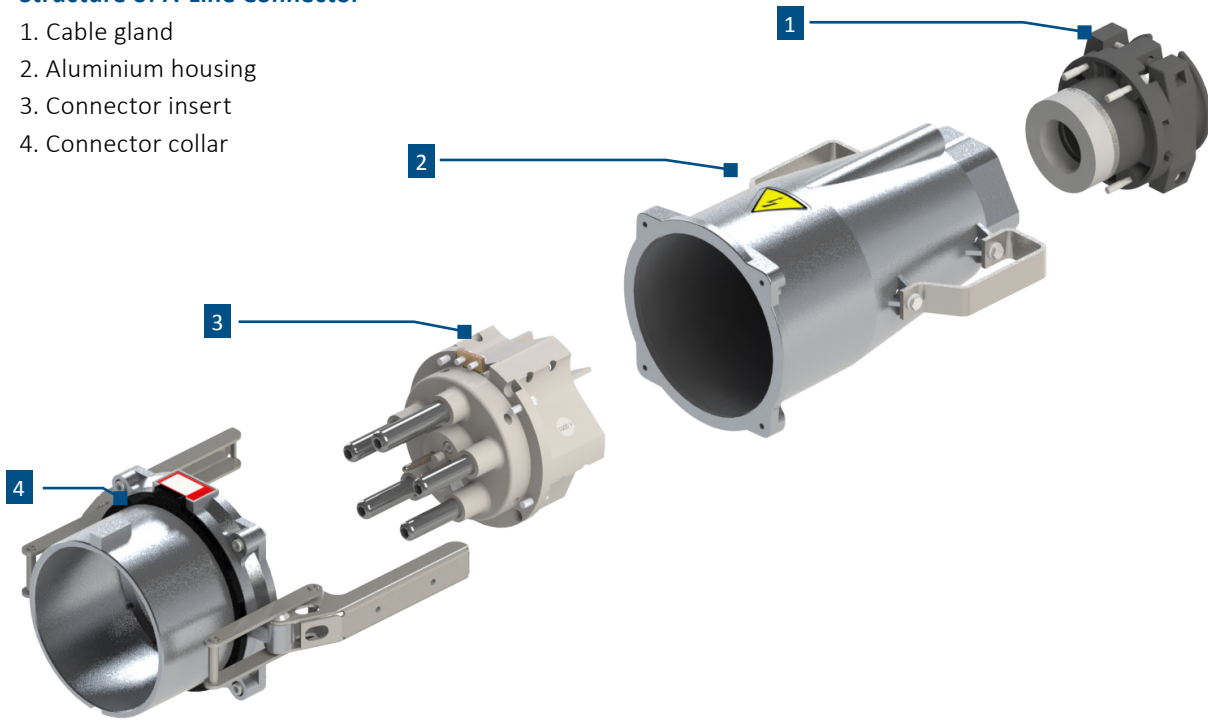

Locking system

Mechanically easy designed locking system, which reduces the force required during plugging and pulling.

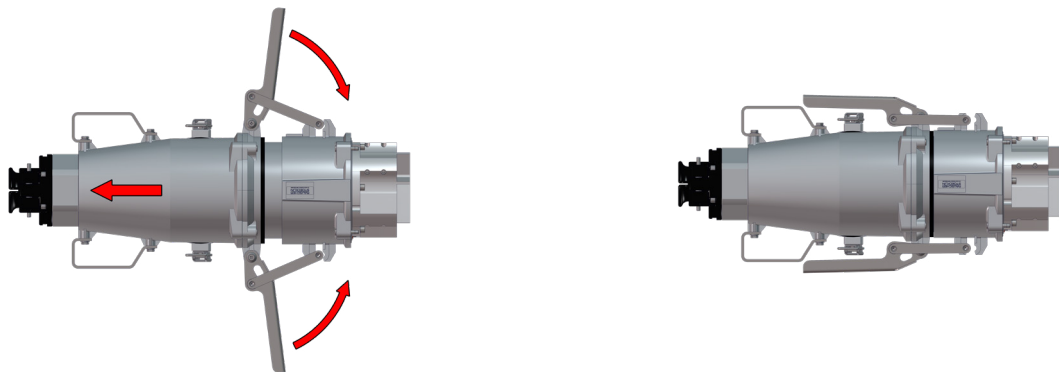

MC

Plug

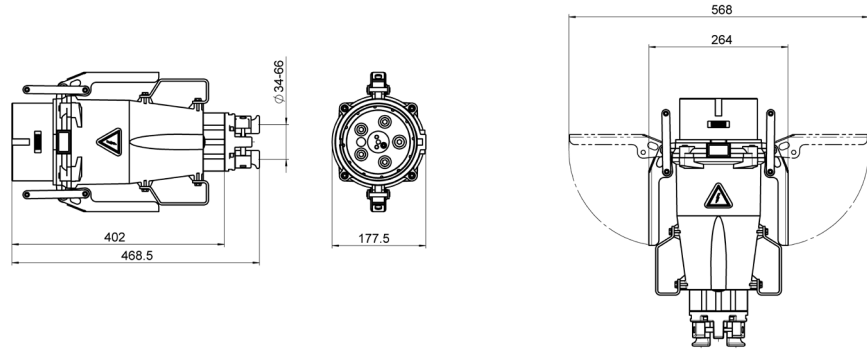

Current	No. of Poles	Voltage	Type designation	Article No.
500 A	4 (3L+PEN)	230V	MC-S4/500 230V-9h	25200
		400V	MC-S4/500 400V-6h	25201
		500V	MC-S4/500 500V-7h	25202
		690V	MC-S4/500 690V-5h	25203
		1000V	MC-S4/500 1000V-1h	25204
	5 (3L+N+PE)	230V	MC-S5/500 230V-9h	25210
		400V	MC-S5/500 400V-6h	25211
		500V	MC-S5/500 500V-7h	25212
		690V	MC-S5/500 690V-5h	25213
		1000V	MC-S5/500 1000V-1h	25214
600 A	4 (3L+PEN)	230V	MC-S4/600 230V-9h	25280
		400V	MC-S4/600 400V-6h	25281
		500V	MC-S4/600 500V-7h	25282
		690V	MC-S4/600 690V-5h	25283
		1000V	MC-S4/600 1000V-1h	25284
	5 (3L+N+PE)	230V	MC-S5/600 230V-9h	25290
		400V	MC-S5/600 400V-6h	25291
		500V	MC-S5/600 500V-7h	25292
		690V	MC-S5/600 690V-5h	25293
		1000V	MC-S5/600 1000V-1h	25294

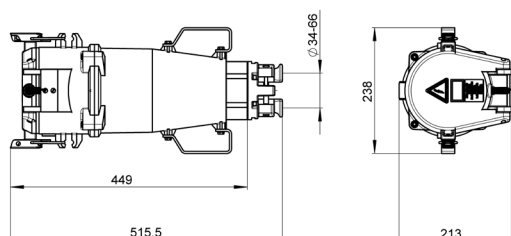

Current	No. of Poles	Voltage	Type designation	Article No.
500 A	4 (3L+PEN)	230V	FC-S4/500 230V-9h	25205
		400V	FC-S4/500 400V-6h	25206
		500V	FC-S4/500 500V-7h	25207
		690V	FC-S4/500 690V-5h	25208
		1000V	FC-S4/500 1000V-1h	25209
	5 (3L+N+PE)	230V	FC-S5/500 230V-9h	25215
		400V	FC-S5/500 400V-6h	25216
		500V	FC-S5/500 500V-7h	25217
		690V	FC-S5/500 690V-5h	25218
		1000V	FC-S5/500 1000V-1h	25219
600 A	4 (3L+PEN)	230V	FC-S4/600 230V-9h	25285
		400V	FC-S4/600 400V-6h	25286
		500V	FC-S4/600 500V-7h	25287
		690V	FC-S4/600 690V-5h	25288
		1000V	FC-S4/600 1000V-1h	25289
	5 (3L+N+PE)	230V	FC-S5/600 230V-9h	25295
		400V	FC-S5/600 400V-6h	25296
		500V	FC-S5/600 500V-7h	25297
		690V	FC-S5/600 690V-5h	25298
		1000V	FC-S5/600 1000V-1h	25299



MCW

Wall Mounted Inlet

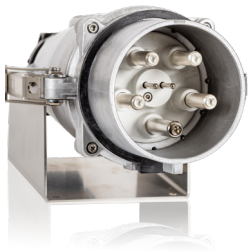
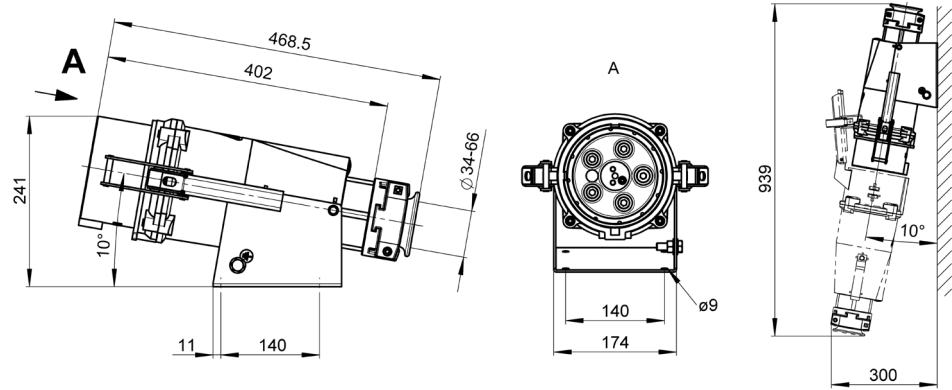

Current	No. of Poles	Voltage	Type designation	Article No.
500 A	4 (3L+PEN)	230V	MCW-S4/500 230V-9h	25220
		400V	MCW-S4/500 400V-6h	25221
		500V	MCW-S4/500 500V-7h	25222
		690V	MCW-S4/500 690V-5h	25223
		1000V	MCW-S4/500 1000V-1h	25224
	5 (3L+N+PE)	230V	MCW-S5/500 230V-9h	25230
		400V	MCW-S5/500 400V-6h	25231
		500V	MCW-S5/500 500V-7h	25232
		690V	MCW-S5/500 690V-5h	25233
		1000V	MCW-S5/500 1000V-1h	25234
600 A	4 (3L+PEN)	230V	MCW-S4/600 230V-9h	25300
		400V	MCW-S4/600 400V-6h	25301
		500V	MCW-S4/600 500V-7h	25302
		690V	MCW-S4/600 690V-5h	25303
		1000V	MCW-S4/600 1000V-1h	25304
	5 (3L+N+PE)	230V	MCW-S5/600 230V-9h	25310
		400V	MCW-S5/600 400V-6h	25311
		500V	MCW-S5/600 500V-7h	25312
		690V	MCW-S5/600 690V-5h	25313
		1000V	MCW-S5/600 1000V-1h	25314

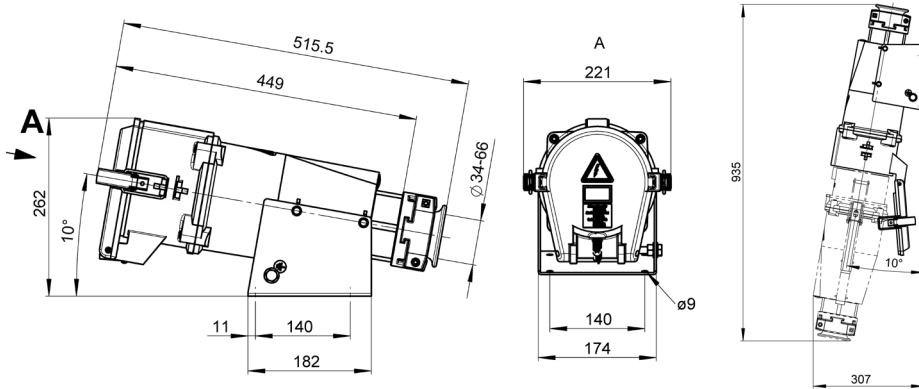

Current	No. of Poles	Voltage	Type designation	Article No.
500 A	4 (3L+PEN)	230V	FCW-S4/500 230V-9h	25225
		400V	FCW-S4/500 400V-6h	25226
		500V	FCW-S4/500 500V-7h	25227
		690V	FCW-S4/500 690V-5h	25228
		1000V	FCW-S4/500 1000V-1h	25229
	5 (3L+N+PE)	230V	FCW-S5/500 230V-9h	25235
		400V	FCW-S5/500 400V-6h	25236
		500V	FCW-S5/500 500V-7h	25237
		690V	FCW-S5/500 690V-5h	25238
		1000V	FCW-S5/500 1000V-1h	25239
600 A	4 (3L+PEN)	230V	FCW-S4/600 230V-9h	25305
		400V	FCW-S4/600 400V-6h	25306
		500V	FCW-S4/600 500V-7h	25307
		690V	FCW-S4/600 690V-5h	25308
		1000V	FCW-S4/600 1000V-1h	25309
	5 (3L+N+PE)	230V	FCW-S5/600 230V-9h	25315
		400V	FCW-S5/600 230V-9h	25316
		500V	FCW-S5/600 500V-7h	25317
		690V	FCW-S5/600 690V-5h	25318
		1000V	FCW-S5/600 1000V-1h	25319



MCP

Panel Mounted Inlet

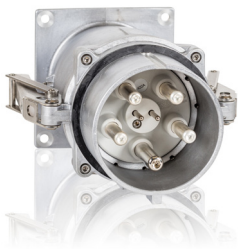
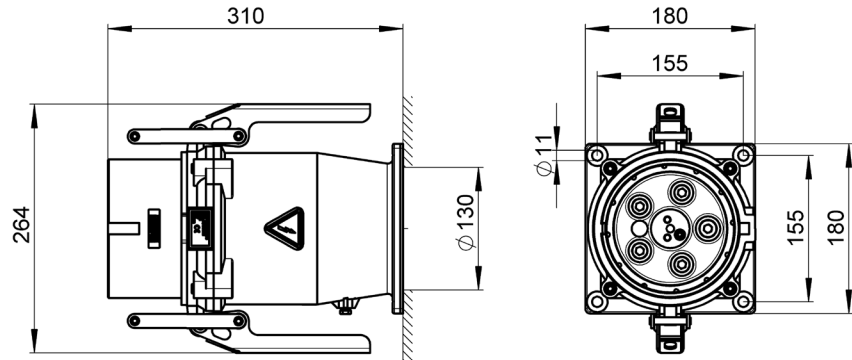

Current	No. of Poles	Voltage	Type designation	Article No.
500 A	4 (3L+PEN)	230V	MCP-S4/500 230V-9h	25240
		400V	MCP-S4/500 400V-6h	25241
		500V	MCP-S4/500 500V-7h	25242
		690V	MCP-S4/500 690V-5h	25243
		1000V	MCP-S4/500 1000V-1h	25244
	5 (3L+N+PE)	230V	MCP-S5/500 230V-9h	25250
		400V	MCP-S5/500 400V-6h	25251
		500V	MCP-S5/500 500V-7h	25252
		690V	MCP-S5/500 690V-5h	25253
		1000V	MCP-S5/500 1000V-1h	25254
600 A	4 (3L+PEN)	230V	MCP-S4/600 230V-9h	25320
		400V	MCP-S4/600 400V-6h	25321
		500V	MCP-S4/600 500V-7h	25322
		690V	MCP-S4/600 690V-5h	25323
		1000V	MCP-S4/600 1000V-1h	25324
	5 (3L+N+PE)	230V	MCP-S5/600 230V-9h	25330
		400V	MCP-S5/600 400V-6h	25331
		500V	MCP-S5/600 500V-7h	25332
		690V	MCP-S5/600 690V-5h	25333
		1000V	MCP-S5/600 1000V-1h	25334

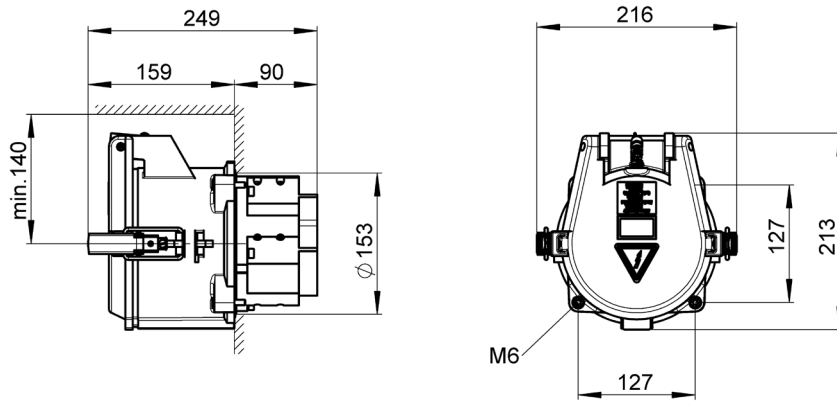

Current	No. of Poles	Voltage	Type designation	Article No.
500 A	4 (3L+PEN)	230V	FCP-S4/500 230V-9h	25245
		400V	FCP-S4/500 400V-6h	25246
		500V	FCP-S4/500 500V-7h	25247
		690V	FCP-S4/500 690V-5h	25248
		1000V	FCP-S4/500 1000V-1h	25249
	5 (3L+N+PE)	230V	FCP-S5/500 230V-9h	25255
		400V	FCP-S5/500 400V-6h	25256
		500V	FCP-S5/500 500V-7h	25257
		690V	FCP-S5/500 690V-5h	25258
		1000V	FCP-S5/500 1000V-1h	25259
600 A	4 (3L+PEN)	230V	FCP-S4/600 230V-9h	25325
		400V	FCP-S4/600 400V-6h	25326
		500V	FCP-S4/600 500V-7h	25327
		690V	FCP-S4/600 690V-5h	25328
		1000V	FCP-S4/600 1000V-1h	25329
	5 (3L+N+PE)	230V	FCP-S5/600 230V-9h	25335
		400V	FCP-S5/600 400V-6h	25336
		500V	FCP-S5/600 500V-7h	25337
		690V	FCP-S5/600 690V-5h	25338
		1000V	FCP-S5/600 1000V-1h	25339

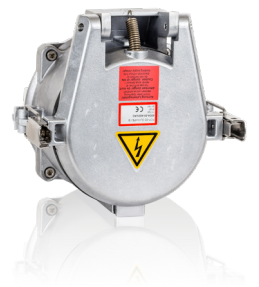

MCPA

Panel Mounted Inlet Angled

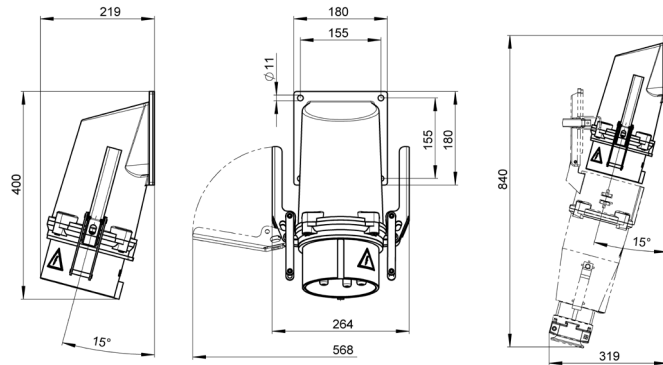

Current	No. of Poles	Voltage	Type designation	Article No.
500 A	4 (3L+PEN)	230V	MCPA-S4/500 230V-9h	25260
		400V	MCPA-S4/500 400V-6h	25261
		500V	MCPA-S4/500 500V-7h	25262
		690V	MCPA-S4/500 690V-5h	25263
		1000V	MCPA-S4/500 1000V-1h	25264
	5 (3L+N+PE)	230V	MCPA-S5/500 230V-9h	25270
		400V	MCPA-S5/500 400V-6h	25271
		500V	MCPA-S5/500 500V-7h	25272
		690V	MCPA-S5/500 690V-5h	25273
		1000V	MCPA-S5/500 1000V-1h	25274
600 A	4 (3L+PEN)	230V	MCPA-S4/600 230V-9h	25340
		400V	MCPA-S4/600 400V-6h	25341
		500V	MCPA-S4/600 500V-7h	25342
		690V	MCPA-S4/600 690V-5h	25343
		1000V	MCPA-S4/600 1000V-1h	25344
	5 (3L+N+PE)	230V	MCPA-S5/600 230V-9h	25350
		400V	MCPA-S5/600 400V-6h	25351
		500V	MCPA-S5/600 500V-7h	25352
		690V	MCPA-S5/600 690V-5h	25353
		1000V	MCPA-S5/600 1000V-1h	25354

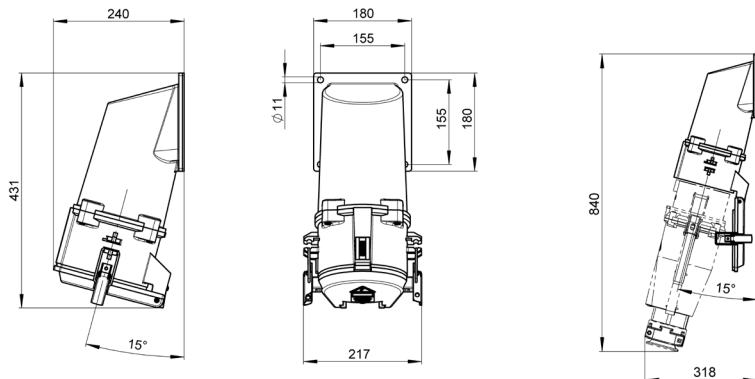

Current	No. of Poles	Voltage	Type designation	Article No.
500 A	4 (3L+PEN)	230V	FCPA-S4/500 230V-9h	25265
		400V	FCPA-S4/500 400V-6h	25266
		500V	FCPA-S4/500 500V-7h	25267
		690V	FCPA-S4/500 690V-5h	25268
		1000V	FCPA-S4/500 1000V-1h	25269
	5 (3L+N+PE)	230V	FCPA-S5/500 230V-9h	25275
		400V	FCPA-S5/500 400V-6h	25276
		500V	FCPA-S5/500 500V-7h	25277
		690V	FCPA-S5/500 690V-5h	25278
		1000V	FCPA-S5/500 1000V-1h	25279
600 A	4 (3L+PEN)	230V	FCPA-S4/600 230V-9h	25345
		400V	FCPA-S4/600 400V-6h	25346
		500V	FCPA-S4/600 500V-7h	25347
		690V	FCPA-S4/600 690V-5h	25348
		1000V	FCPA-S4/600 1000V-1h	25349
	5 (3L+N+PE)	230V	FCPA-S5/600 230V-9h	25355
		400V	FCPA-S5/600 400V-6h	25356
		500V	FCPA-S5/600 500V-7h	25357
		690V	FCPA-S5/600 690V-5h	25358
		1000V	FCPA-S5/600 1000V-1h	25359



Options

Enhancements for every application



Seawater resistant connector

For port applications, an option often requested by the customer. The seawater-resistant design prevents oxidation on the housing.

Seawater resistant connectors upon request.

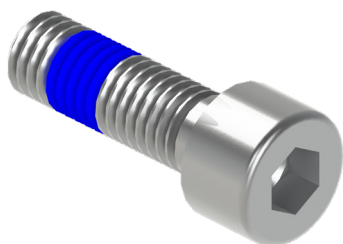

Vibration resistant connectors

On request there are vibration resistant connectors available. This option is frequently asked for railway applications.



Accessories:

- Cover cap (article No.: 12123)
- Cable gland up to \varnothing 80mm
 - 66 - 69.5mm - article No 12126
 - 68 - 74mm - article No: 12127
 - 74 - 80mm - article No: 22013
- Padlock (article Nor: 14349)

General information

Special features for A-Line connectors

Some product features listed in the catalog apply only to the A-Line connectors.

This includes:

- Exchangeable contacts
- Resistant housing up to 2 tons load

Weight and packaging-information

Article		Weight (kg)	Packaging Bulk outside (mm)
Plug MC	4-polig	7.1	462 x 240 x 242
	5-polig	8.6	462 x 240 x 242
Panel Mounted Inlet MCP	4-polig	8.1	275 x 230 x 350
	5-polig	8.6	275 x 230 x 350
Panel Mounted Inlet Angled MCPA	4-polig	9.8	462 x 240 x 242
	5-polig	10.3	462 x 240 x 242
Wall Mounted Inlet MCW	4-polig	10.0	462 x 240 x 242
	5-polig	10.5	462 x 240 x 242
Coupling FC	4-polig	9.4	462 x 240 x 242
	5-polig	9.9	462 x 240 x 242
Panel Mounted Receptacle FCP	4-polig	6.8	275 x 230 x 350
	5-polig	7.3	275 x 230 x 350
Panel Mounted Receptacle Angled FCPA	4-polig	10.3	462 x 240 x 242
	5-polig	10.8	462 x 240 x 242
Wall Mounted Receptacle FCW	4-polig	11.5	462 x 240 x 242
	5-polig	12.0	462 x 240 x 242

Connector Unit

CUMI



Technical Data	Unit	D-Line	C-Line	B - Line	A-Line
Nominal current	A	160	200	250	250 315 400 500 600
Rated current	A	160	250	285	315 380 450 500 600
Rated voltage	V	1'000			
Rated frequency	Hz	50 / 60			
Withstand voltage (1 Min / 50 Hz)	V	4'000			
Protection grade		IP 55			
Shock resistance		IK 07			
Ambient temperature	°C	-40 / +70			
Insulation resistance (phase to phase and phase to earth)	MOhm	> 500			
Comparative tracking index of the insert	CTI	> 600			
Weight 4-pol. (3L+PEN)	kg	25.1		45.6	
Weight 5-pol. (3L+N+PE)	kg	25.3		47.1	
Connector bolts for cable shoes		M8		M10	
Max. cross section pilot cable, conductor (EN 60228 Class 1)	mm ²	4		4	
Diameter of cable					
- normal	mm	20 - 70			
other diameters on request					

Technical modifications reserved

Structure

Locking system

Male connector will be connected to connector unit. Switch is manually set to the „ON“ position. Connector is now under load and is mechanically locked via a linkage integrated in the connector unit.

Only by moving the switch to the „OFF“ position the connector can be disconnected from the connector unit.

Important!

Plugging is not possible under load!

Construction of a CUMI connector unit

1. Cable gland
2. Load break switch
3. Linkage
4. Switch
5. Panel Mounted Receptacle

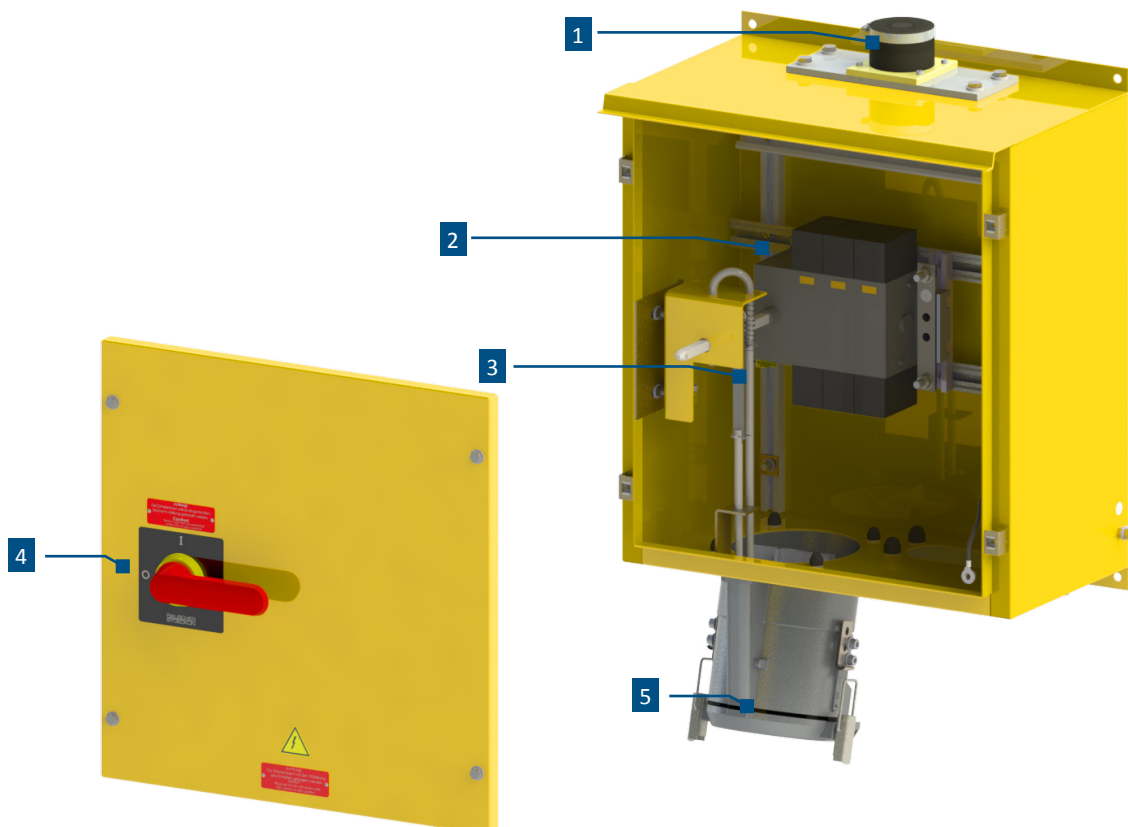

CUMI D - Line

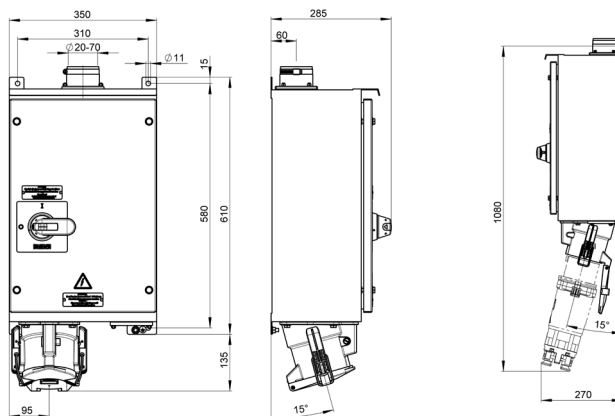

Current	No. of Poles	Voltage	Type designation	Article No.
160 A	4 (3L+PEN)	230V	CUMI-S4/160 230V-9h	25360
		400V	CUMI-S4/160 400V-6h	25361
		500V	CUMI-S4/160 500V-7h	25362
		690V	CUMI-S4/160 690V-5h	25363
		1000V	CUMI-S4/160 1000V-1h	25364
	5 (3L+N+PE)	230V	CUMI-S5/160 230V-9h	25375
		400V	CUMI-S5/160 400V-6h	25376
		500V	CUMI-S5/160 500V-7h	25377
		690V	CUMI-S5/160 690V-5h	25378
		1000V	CUMI-S5/160 1000V-1h	25379



CUMI C - Line

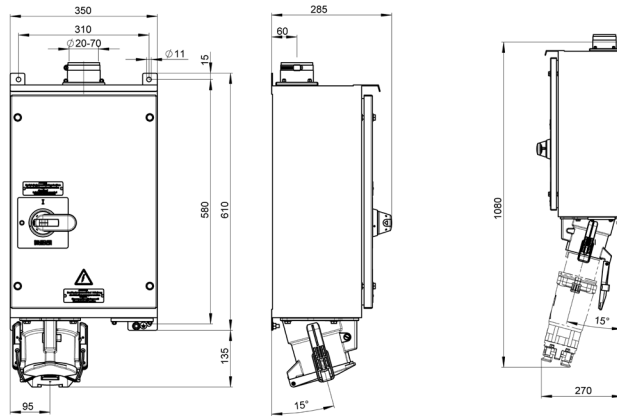

Current	No. of Poles	Voltage	Type designation	Article No.
200 A	4 (3L+PEN)	230V	CUMI-S4/200 230V-9h	11790
		400V	CUMI-S4/200 400V-6h	11791
		500V	CUMI-S4/200 500V-7h	11792
		690V	CUMI-S4/200 690V-5h	11793
		1000V	CUMI-S4/200 1000V-1h	11794
	5 (3L+N+PE)	230V	CUMI-S5/200 230V-9h	11795
		400V	CUMI-S5/200 400V-6h	11796
		500V	CUMI-S5/200 500V-7h	11797
		690V	CUMI-S5/200 690V-5h	11798
		1000V	CUMI-S5/200 1000V-1h	11799
250 A	4 (3L+PEN)	230V	CUMI-S4/250 230V-9h	22160
		400V	CUMI-S4/250 400V-6h	22161
		500V	CUMI-S4/250 500V-7h	22162
		690V	CUMI-S4/250 690V-5h	22163
		1000V	CUMI-S4/250 1000V-1h	22164
	5 (3L+N+PE)	230V	CUMI-S5/250 230V-9h	22165
		400V	CUMI-S5/250 400V-6h	22166
		500V	CUMI-S5/250 500V-7h	22167
		690V	CUMI-S5/250 690V-5h	22168
		1000V	CUMI-S5/250 1000V-1h	22169

CUMI B - Line

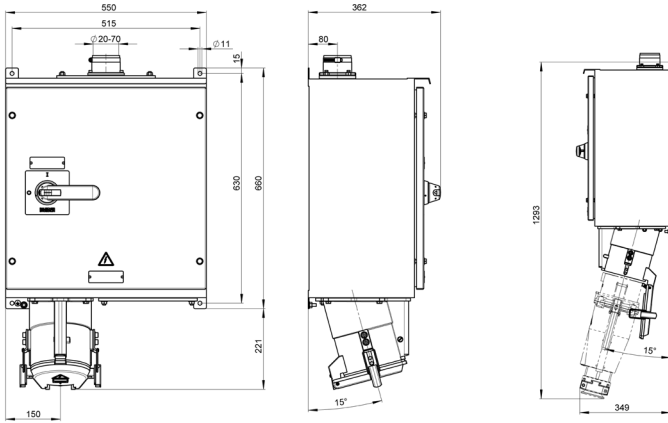

Current	No. of Poles	Voltage	Type designation	Article No.
250A	4 (3L+PEN)	230V	CUMI-S4/250 230V-9h	11800
		400V	CUMI-S4/250 400V-6h	11801
		500V	CUMI-S4/250 500V-7h	11802
		690V	CUMI-S4/250 690V-5h	11803
		1000V	CUMI-S4/250 1000V-1h	11804
	5 (3L+N+PE)	230V	CUMI-S5/250 230V-9h	11805
		400V	CUMI-S5/250 400V-6h	11806
		500V	CUMI-S5/250 500V-7h	11807
		690V	CUMI-S5/250 690V-5h	11808
		1000V	CUMI-S5/250 1000V-1h	11809
315 A	4 (3L+PEN)	230V	CUMI-S4/315 230V-9h	22960
		400V	CUMI-S4/315 400V-6h	22961
		500V	CUMI-S4/315 500V-7h	22962
		690V	CUMI-S4/315 690V-5h	22963
		1000V	CUMI-S4/315 1000V-1h	22964
	5 (3L+N+PE)	230V	CUMI-S5/315 230V-9h	22965
		400V	CUMI-S5/315 400V-6h	22966
		500V	CUMI-S5/315 500V-7h	22967
		690V	CUMI-S5/315 690V-5h	22968
		1000V	CUMI-S5/315 1000V-1h	22969
400 A	4 (3L+PEN)	230V	CUMI-S4/400 230V-9h	11810
		400V	CUMI-S4/400 400V-6h	11811
		500V	CUMI-S4/400 500V-7h	11812
		690V	CUMI-S4/400 690V-5h	11813
		1000V	CUMI-S4/400 1000V-1h	11814
	5 (3L+N+PE)	230V	CUMI-S5/400 230V-9h	11815
		400V	CUMI-S5/400 400V-6h	11816
		500V	CUMI-S5/400 500V-7h	11817
		690V	CUMI-S5/400 690V-5h	11818
		1000V	CUMI-S5/400 1000V-1h	11819



CUMI A - Line

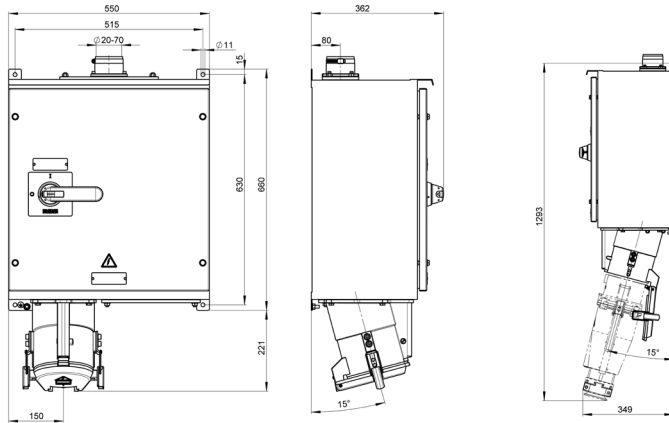

Current	No. of Poles	Voltage	Type designation	Article No.
500 A	4 (3L+PEN)	230V	CUMI-S4/500 230V-9h	25365
		400V	CUMI-S4/500 400V-6h	25366
		500V	CUMI-S4/500 500V-7h	25367
		690V	CUMI-S4/500 690V-5h	25368
		1000V	CUMI-S4/500 1000V-1h	25369
	5 (3L+N+PE)	230V	CUMI-S5/500 230V-9h	25380
		400V	CUMI-S5/500 400V-6h	25381
		500V	CUMI-S5/500 500V-7h	25382
		690V	CUMI-S5/500 690V-5h	25383
		1000V	CUMI-S5/500 1000V-1h	25384
600 A	4 (3L+PEN)	230V	CUMI-S4/600 230V-9h	25370
		400V	CUMI-S4/600 400V-6h	25371
		500V	CUMI-S4/600 500V-7h	25372
		690V	CUMI-S4/600 690V-5h	25373
		1000V	CUMI-S4/600 1000V-1h	25374
	5 (3L+N+PE)	230V	CUMI-S5/600 230V-9h	25385
		400V	CUMI-S5/600 400V-6h	25386
		500V	CUMI-S5/600 500V-7h	25387
		690V	CUMI-S5/600 690V-5h	25388
		1000V	CUMI-S5/600 1000V-1h	25389



Connector Unit

CUBC

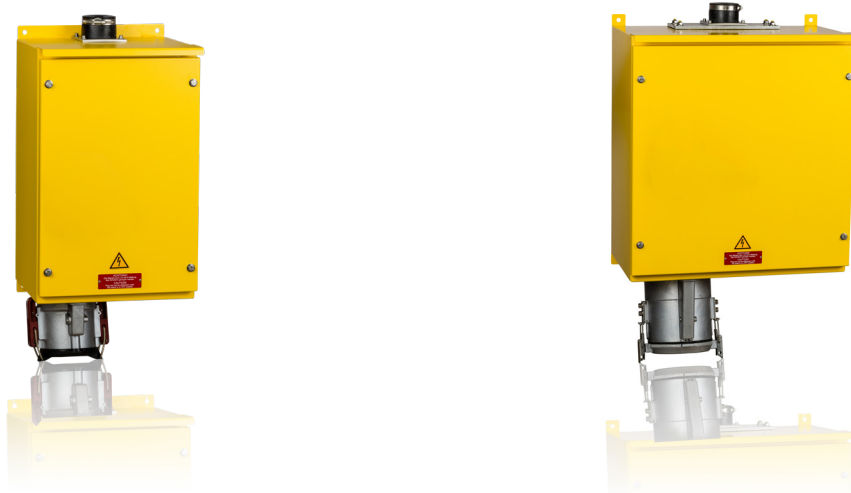

Technical Data	Unit	D-Line	C-Line	B - Line	A-Line				
Nominal current	A	160	200	250	250	315	400	500	600
Rated current	A	160	250	285	315	380	450	500	600
Rated voltage	V	1'000							
Rated frequency	Hz	50 / 60							
Withstand voltage (1 Min / 50 Hz)	V	4'000							
Protection grade		IP 55							
Shock resistance		IK 07							
Ambient temperature	°C	-40 / +70							
Insulation resistance (phase to phase and phase to earth)	MOhm	> 500							
Comparative tracking index of the insert	CTI	> 600							
Weight 4-pol. (3L+PEN)	kg		25.1					45.6	
Weight 5-pol. (3L+N+PE)	kg		25.3					47.1	
Connection bolts for cable shoes			M8					M10	
Max. cross section pilot cable, conductor (EN 60228 Class 1)	mm ²	4							
Diameter of cable									
- normal	mm	20 - 70							
other diameters on request									

Technical modifications reserved

Structure

Locking system

A contactor is installed in the CUBC connector unit. During every plug-in operation, the standardly installed pilot contacts in the connector transmit a signal to the contactors.

The main contacts in the connector unit are subsequently closed. Thus the connection is under load. Furthermore, the electrical connection will be disconnected immediately by the pilot contacts, if an unintentional manual disconnection is conducted.

Construction of a CUBC connection box

1. Cable gland
2. Contactor
3. Panel Mounted Receptacle

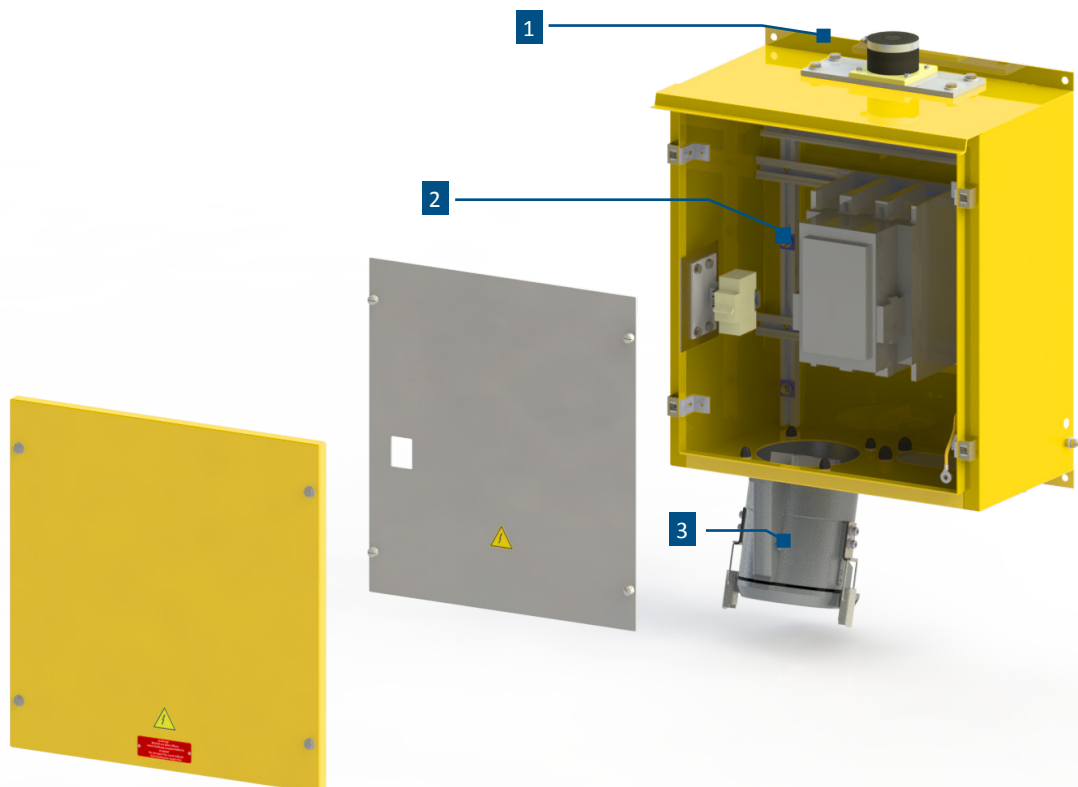

CUBC D - Line

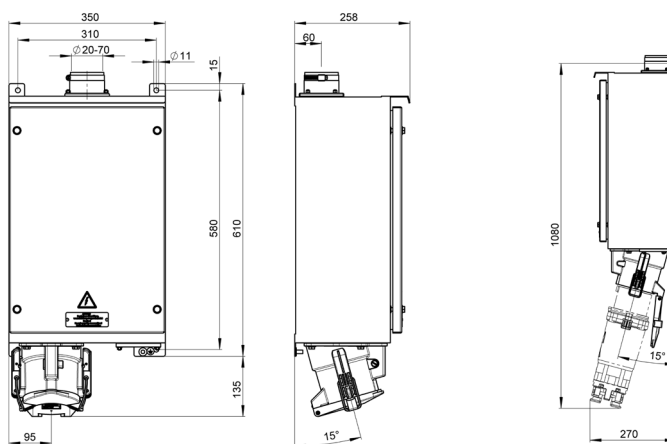

Current	No. of Poles	Voltage	Type designation	Article No.
160 A	4 (3L+PEN)	230V	CUBC-S4/160 230V-9h	25390
		400V	CUBC-S4/160 400V-6h	25391
		500V	CUBC-S4/160 500V-7h	25392
		690V	CUBC-S4/160 690V-5h	25393
		1000V	CUBC-S4/160 1000V-1h	25394
	5 (3L+N+PE)	230V	CUBC-S5/160 230V-9h	25405
		400V	CUBC-S5/160 400V-6h	25406
		500V	CUBC-S5/160 500V-7h	25407
		690V	CUBC-S5/160 690V-5h	25408
		1000V	CUBC-S5/160 1000V-1h	25409



CUBC C - Line

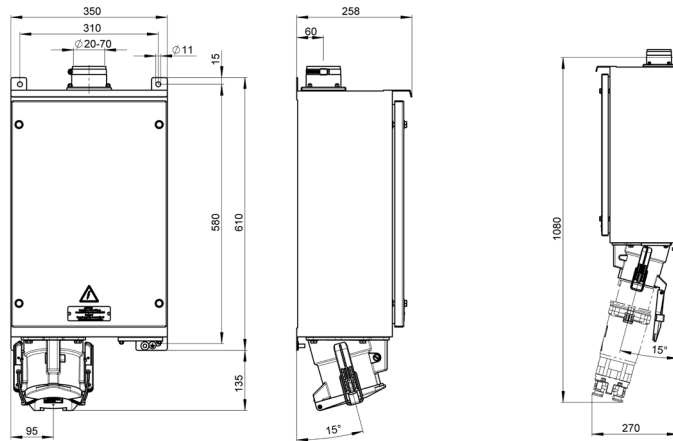

Current	No. of Poles	Voltage	Type designation	Article No.
200 A	4 (3L+PEN)	230V	CUBC-S4/200 230V-9h	11820
		400V	CUBC-S4/200 400V-6h	11821
		500V	CUBC-S4/200 500V-7h	11822
		690V	CUBC-S4/200 690V-5h	11823
		1000V	CUBC-S4/200 1000V-1h	11824
	5 (3L+N+PE)	230V	CUBC-S5/200 230V-9h	11825
		400V	CUBC-S5/200 400V-6h	11826
		500V	CUBC-S5/200 500V-7h	11827
		690V	CUBC-S5/200 690V-5h	11828
		1000V	CUBC-S5/200 1000V-1h	11829
250 A	4 (3L+PEN)	230V	CUBC-S4/250 230V-9h	22170
		400V	CUBC-S4/250 400V-6h	22171
		500V	CUBC-S4/250 500V-7h	22172
		690V	CUBC-S4/250 690V-5h	22173
		1000V	CUBC-S4/250 1000V-1h	22174
	5 (3L+N+PE)	230V	CUBC-S5/250 230V-9h	22175
		400V	CUBC-S5/250 400V-6h	22176
		500V	CUBC-S5/250 500V-7h	22177
		690V	CUBC-S5/250 690V-5h	22178
		1000V	CUBC-S5/250 1000V-1h	22179

CUBC B - Line

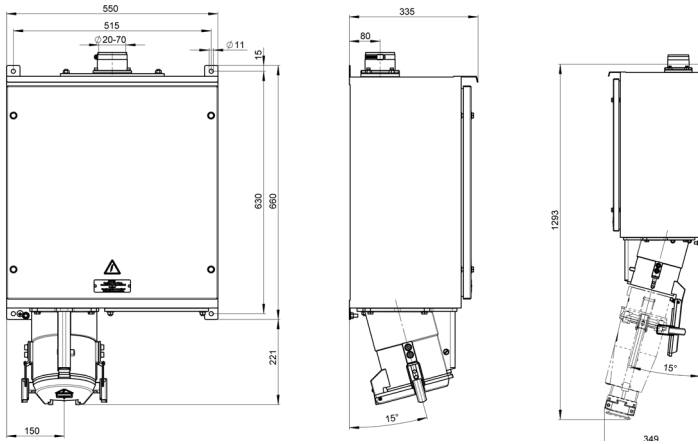

Current	No. of Poles	Voltage	Type designation	Article No.
250A	4 (3L+PEN)	230V	CUBC-S4/250 230V-9h	11830
		400V	CUBC-S4/250 400V-6h	11831
		500V	CUBC-S4/250 500V-7h	11832
		690V	CUBC-S4/250 690V-5h	11833
		1000V	CUBC-S4/250 1000V-1h	11834
	5 (3L+N+PE)	230V	CUBC-S5/250 230V-9h	11835
		400V	CUBC-S5/250 400V-6h	11836
		500V	CUBC-S5/250 500V-7h	11837
		690V	CUBC-S5/250 690V-5h	11838
		1000V	CUBC-S5/250 1000V-1h	11839
315 A	4 (3L+PEN)	230V	CUBC-S4/315 230V-9h	22970
		400V	CUBC-S4/315 400V-6h	22971
		500V	CUBC-S4/315 500V-7h	22972
		690V	CUBC-S4/315 690V-5h	22973
		1000V	CUBC-S4/315 1000V-1h	22974
	5 (3L+N+PE)	230V	CUBC-S5/315 230V-9h	22975
		400V	CUBC-S5/315 400V-6h	22976
		500V	CUBC-S5/315 500V-7h	22977
		690V	CUBC-S5/315 690V-5h	22978
		1000V	CUBC-S5/315 1000V-1h	22979
400 A	4 (3L+PEN)	230V	CUBC-S4/400 230V-9h	11840
		400V	CUBC-S4/400 400V-6h	11841
		500V	CUBC-S4/400 500V-7h	11842
		690V	CUBC-S4/400 690V-5h	11843
		1000V	CUBC-S4/400 1000V-1h	11844
	5 (3L+N+PE)	230V	CUBC-S5/400 230V-9h	11845
		400V	CUBC-S5/400 400V-6h	11846
		500V	CUBC-S5/400 500V-7h	11847
		690V	CUBC-S5/400 690V-5h	11848
		1000V	CUBC-S5/400 1000V-1h	11849



CUBC A - Line

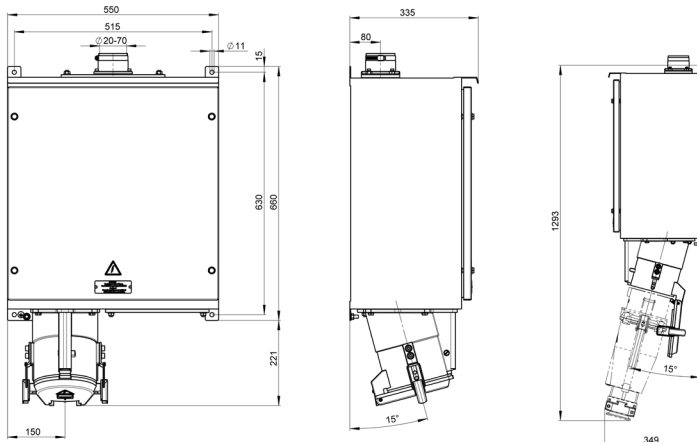

Current	No. of Poles	Voltage	Type designation	Article No.
500 A	4 (3L+PEN)	230V	CUBC-S4/500 230V-9h	25395
		400V	CUBC-S4/500 400V-6h	25396
		500V	CUBC-S4/500 500V-7h	25397
		690V	CUBC-S4/500 690V-5h	25398
		1000V	CUBC-S4/500 1000V-1h	25399
	5 (3L+N+PE)	230V	CUBC-S5/500 230V-9h	25410
		400V	CUBC-S5/500 400V-6h	25411
		500V	CUBC-S5/500 500V-7h	25412
		690V	CUBC-S5/500 690V-5h	25413
		1000V	CUBC-S5/500 1000V-1h	25414
600 A	4 (3L+PEN)	230V	CUBC-S4/600 230V-9h	25400
		400V	CUBC-S4/600 400V-6h	25401
		500V	CUBC-S4/600 500V-7h	25402
		690V	CUBC-S4/600 690V-5h	25403
		1000V	CUBC-S4/600 1000V-1h	25404
	5 (3L+N+PE)	230V	CUBC-S5/600 230V-9h	25415
		400V	CUBC-S5/600 400V-6h	25416
		500V	CUBC-S5/600 500V-7h	25417
		690V	CUBC-S5/600 690V-5h	25418
		1000V	CUBC-S5/600 1000V-1h	25419



Connector Unit

CUCB



Technical Data	Unit	D-Line	C-Line			B - Line		A-Line	
Nominal current	A	160	200	250	250	315	400	500	600
Rated current	A	160	250	285	315	380	450	500	600
Rated voltage	V	690							
Rated ultimate short-circuit breaking capacity I _{cu} (400V)	kA	36							
Thermo magnetic current setting range	A	200		250	250	315	400		
Rated frequency	Hz	50 / 60							
Withstand voltage (1 Min / 50 Hz)	V	3'000							
Protection grade		IP 54							
Shock resistance		IK 07							
Ambient temperature	°C	-40 / +70							
Insulation resistance (phase to phase and phase to earth)	MOhm	> 500							
Comparative tracking index of the insert	CTI	> 600							
Weight 4-pol. (3L+PEN)	kg	25.1			45.6				
Weight 5-pol. (3L+N+PE)	kg	25.3			47.1				
Connection bolts for cable shoes		M10							
Max. cross section pilot cable, conductor (EN 60228 Class 1)	mm ²	4							
Diameter of cable - normal other diameters on request	mm	20 - 70							

Technical modifications reserved

Structure

Locking system

A circuit breaker is installed in the CUCB connector unit. During every plug-in operation, the standardly installed pilot contacts in the connector transmit a signal to the circuit breaker.

The main contacts in the connector unit can be manually closed via the switch afterwards. Thus the connection is under load.

In addition, the CUCB has an overload protection device, which safely disconnects the connection even in the event of damage to other connected devices.

On request, a residual current circuit breaker „RCD“ is also available.

Construction of a CUCB connection box

1. Cable gland
2. Switch
3. Panel Mounted Receptacle

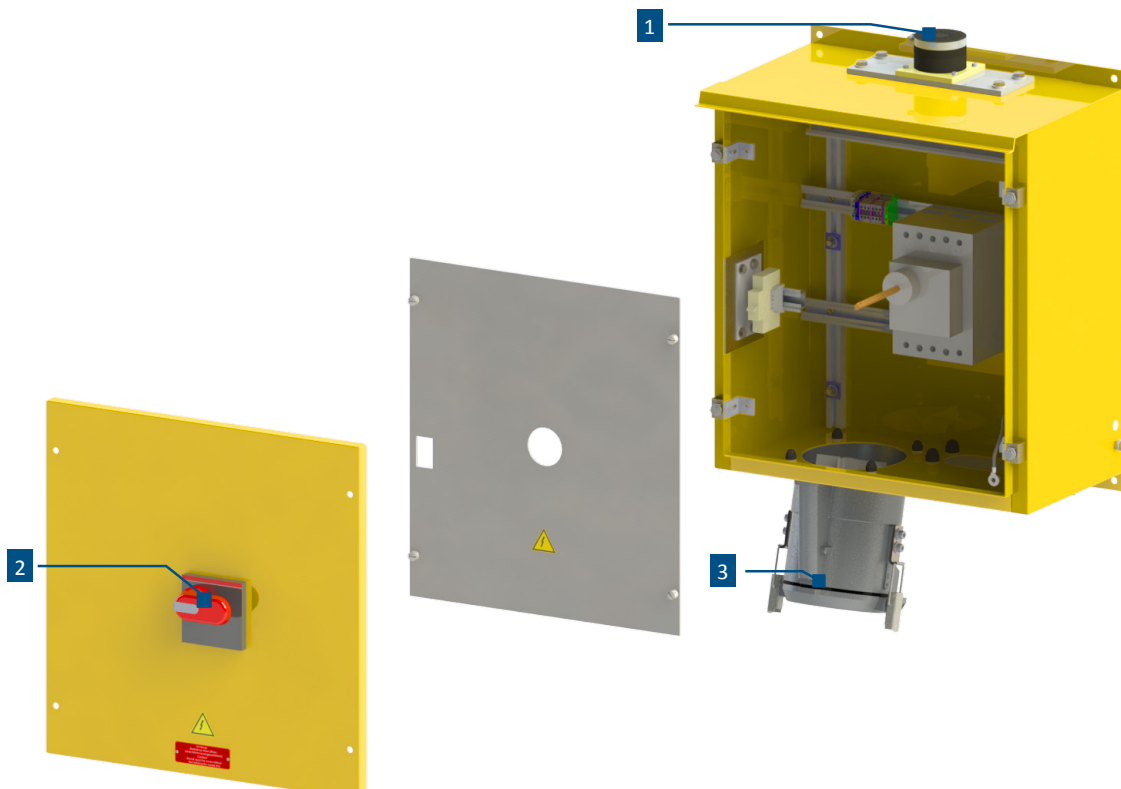

CUCB D - Line

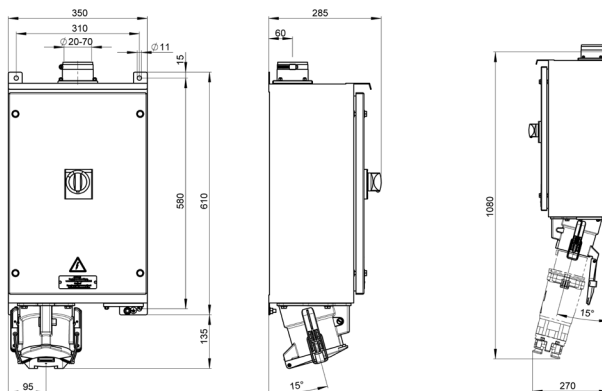

Current	No. of Poles	Voltage	Type designation	Article No.
160 A	4 (3L+PEN)	230V	CUCB-S4/160 230V-9h	25420
		400V	CUCB-S4/160 400V-6h	25421
		500V	CUCB-S4/160 500V-7h	25422
		690V	CUCB-S4/160 690V-5h	25423
		1000V	CUCB-S4/160 1000V-1h	25424
	5 (3L+N+PE)	230V	CUCB-S5/160 230V-9h	25435
		400V	CUCB-S5/160 400V-6h	25436
		500V	CUCB-S5/160 500V-7h	25437
		690V	CUCB-S5/160 690V-5h	25438
		1000V	CUCB-S5/160 1000V-1h	25439

CUCB C - Line

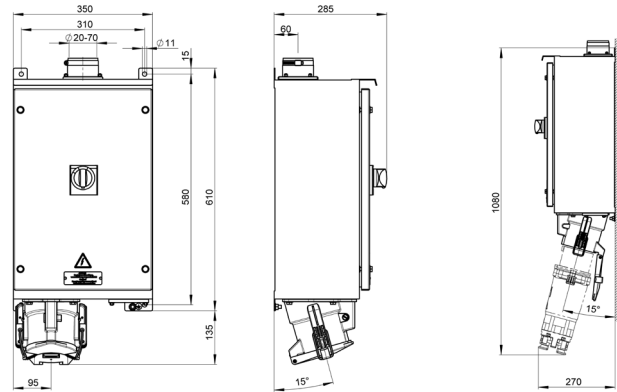

Current	No. of Poles	Voltage	Type designation	Article No.
200 A	4 (3L+PEN)	230V	CUCB-S4/200 230V-9h	17360
		400V	CUCB-S4/200 400V-6h	17361
		500V	CUCB-S4/200 500V-7h	17362
		690V	CUCB-S4/200 690V-5h	17363
	5 (3L+N+PE)	230V	CUCB-S5/200 400V-6h	17365
		400V	CUCB-S5/200 500V-7h	17366
		500V	CUCB-S5/200 690V-5h	17367
		690V	CUCB-S4/250 230V-9h	17368
250 A	4 (3L+PEN)	230V	CUCB-S4/250 500V-7h	22180
		400V	CUCB-S4/250 690V-5h	22181
		500V	CUCB-S5/250 230V-9h	22182
		690V	CUCB-S5/250 400V-6h	22183
	5 (3L+N+PE)	230V	CUCB-S5/250 690V-5h	22185
		400V	CUBC-S5/250 400V-6h	22186
		500V	CUBC-S5/250 500V-7h	22187
		690V	CUBC-S5/250 690V-5h	22188

CUCB B - Line

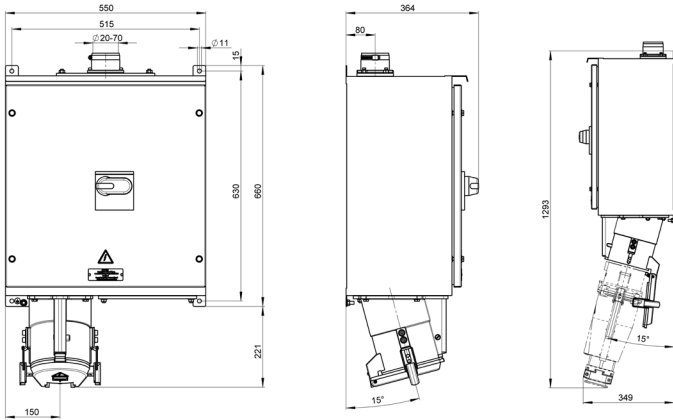

Current	No. of Poles	Voltage	Type designation	Article No.
250A	4 (3L+PEN)	230V	CUCB-S4/250 230V-9h	17370
		400V	CUCB-S4/250 400V-6h	17371
		500V	CUCB-S4/250 500V-7h	17372
		690V	CUCB-S4/250 690V-5h	17373
	5 (3L+N+PE)	230V	CUCB-S5/250 400V-6h	17375
		400V	CUCB-S5/250 500V-7h	17376
		500V	CUCB-S5/250 690V-5h	17377
		690V	CUCB-S4/315 230V-9h	17378
315 A	4 (3L+PEN)	230V	CUCB-S4/315 500V-7h	22980
		400V	CUCB-S4/315 690V-5h	22981
		500V	CUCB-S5/315 230V-9h	22982
		690V	CUCB-S5/315 400V-6h	22983
	5 (3L+N+PE)	230V	CUCB-S5/315 690V-5h	22984
		400V	CUCB-S4/400 230V-9h	22985
		500V	CUCB-S4/400 400V-6h	22986
		690V	CUCB-S4/400 500V-7h	22987
400 A	4 (3L+PEN)	230V	CUCB-S5/400 230V-9h	17380
		400V	CUCB-S5/400 400V-6h	17381
		500V	CUCB-S5/400 500V-7h	17382
		690V	CUCB-S5/400 690V-5h	17383
	5 (3L+N+PE)	230V	CUBC-S5/400 230V-9h	17385
		400V	CUBC-S5/400 400V-6h	17386
		500V	CUBC-S5/400 500V-7h	17387
		690V	CUBC-S5/400 690V-5h	17388



CUCB A - Line

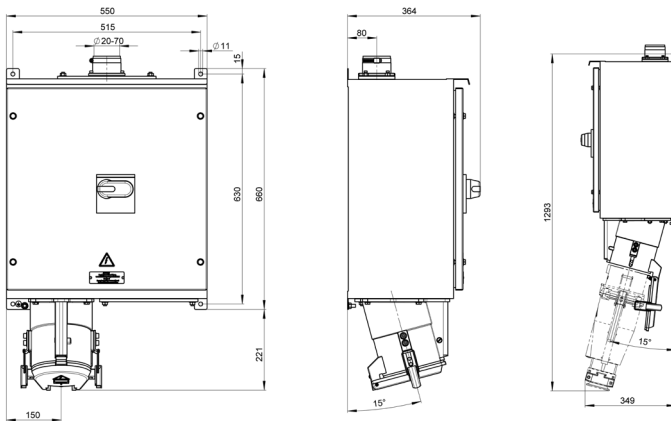

Current	No. of Poles	Voltage	Type designation	Article No.
500 A	4 (3L+PEN)	230V	CUCB-S4/500 230V-9h	25425
		400V	CUCB-S4/500 400V-6h	25426
		500V	CUCB-S4/500 500V-7h	25427
		690V	CUCB-S4/500 690V-5h	25428
		1000V	CUCB-S4/500 1000V-1h	25429
	5 (3L+N+PE)	230V	CUCB-S5/500 230V-9h	25440
		400V	CUCB-S5/500 400V-6h	25441
		500V	CUCB-S5/500 500V-7h	25442
		690V	CUCB-S5/500 690V-5h	25443
		1000V	CUCB-S5/500 1000V-1h	25444
600 A	4 (3L+PEN)	230V	CUCB-S4/600 230V-9h	25430
		400V	CUCB-S4/600 400V-6h	25431
		500V	CUCB-S4/600 500V-7h	25432
		690V	CUCB-S4/600 690V-5h	25433
		1000V	CUCB-S4/600 1000V-1h	25434
	5 (3L+N+PE)	230V	CUCB-S5/600 230V-9h	25445
		400V	CUCB-S5/600 400V-6h	25446
		500V	CUCB-S5/600 500V-7h	25447
		690V	CUCB-S5/600 690V-5h	25448
		1000V	CUCB-S5/600 1000V-1h	25449



Customized Solutions

Special designs upon request

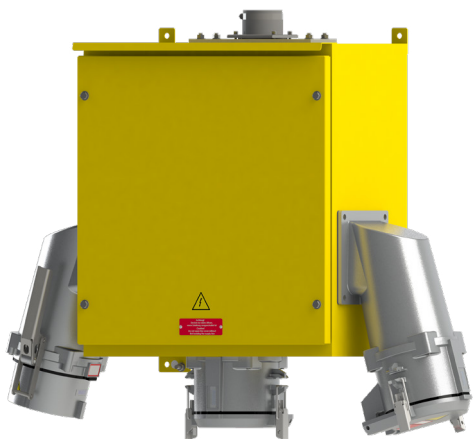

CUBC for special applications

The project - specific connector unit CUBC was designed for a tunnel construction application on customer request. Several machines could be connected at the same time and the workload was reduced to a minimum.



CUMI with CEE connectors

In cooperation with renowned manufacturers of CEE connectors, Rauscher & Stoecklin AG develops solutions that go beyond the normal portfolio.



Connector unit 2 in 1

In order to make optimum use of limited space conditions, a connection box has been designed on request which takes over the function of two connector units.

Options

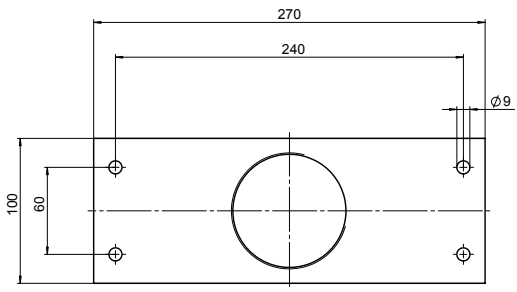
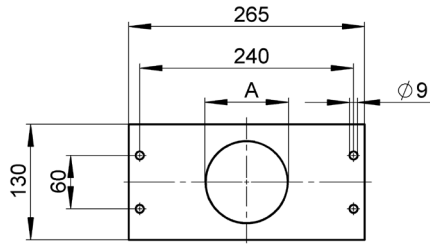
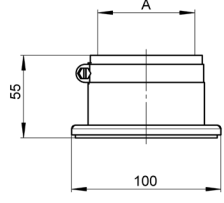
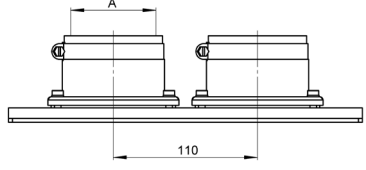
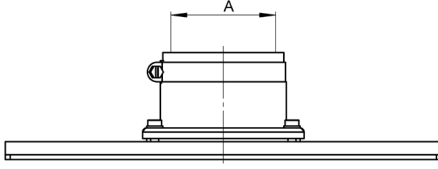
Description	Image	A	Cable Ø	Weight	Article No.
Seawater resistant connector unit					On request
Cover plate for B-Line		1xM64x2	43-53 mm	0.50 kg	12135
Cover plate for B-Line		1xM94x2	62-80 mm	0.60 kg	12137
Cover plate with 1 introduction clip for C-Line		1x Ø70	20-70 mm	0.31 kg	22009
Cover plate including two cable entry sleeves for B - Line		2x Ø70	2x20-70 mm	1.18 kg	12138
Cover plate with 1 introduction clip for B-Line		1x Ø70	20-70 mm	0.85 kg	21195

Technical modifications reserved

Applications

High current connectors can be used in every industry.

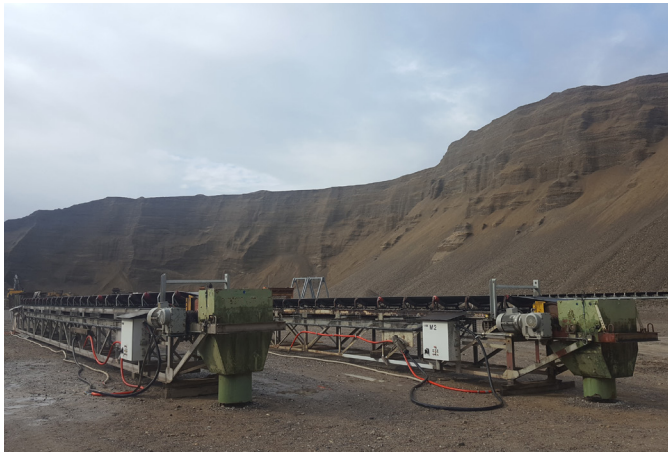

Gravel plant

Connectors are used for the power supply of conveyor belts.

IP67 and IK10 provide protection against external loads.



Tunnel construction

Large construction machines are increasingly operated with electrical energy in order to protect users from smog.



Marine

Power supply of underwater motor pumps.



Tunnel construction

Mobile distribution transformers - sleds are equipped with connector units to ensure safe energy distribution.



Railway

Customized connector unit facilitates the daily work of the work.



Railway

Connectors are used in the depot for power supply.

Notes

Companies of R&S

R&S International Holding

Reuslistrasse 32
4450 Sissach
Switzerland
info@the-rsgroup.com
www.the-rsgroup.com

SERW

Tymákovská 42, Sedlec
332 02 Starý Plzenec
Czech Republic
serw@serw.cz
www.serw.cz

Tesar

Loc. Chiaveretto
52010 Subbiano - Arezzo
Italy
info@tesar.eu
www.tesar.eu

Rauscher & Stoecklin

Reuslistrasse 32
4450 Sissach
Switzerland
info@raustoc.ch
www.raustoc.ch

ZREW Transformers

ul. Rokicińska 144
92-412 Łódź
Poland
transformatory@zrew-tr.pl
www.zrew-transformatory.pl

Tesar Polska

ul. Skarbowska 34
32-005 Niepołomice
Poland
info@tesarpolska.pl
www.tesarpolska.pl