

EKD SYSTEMS

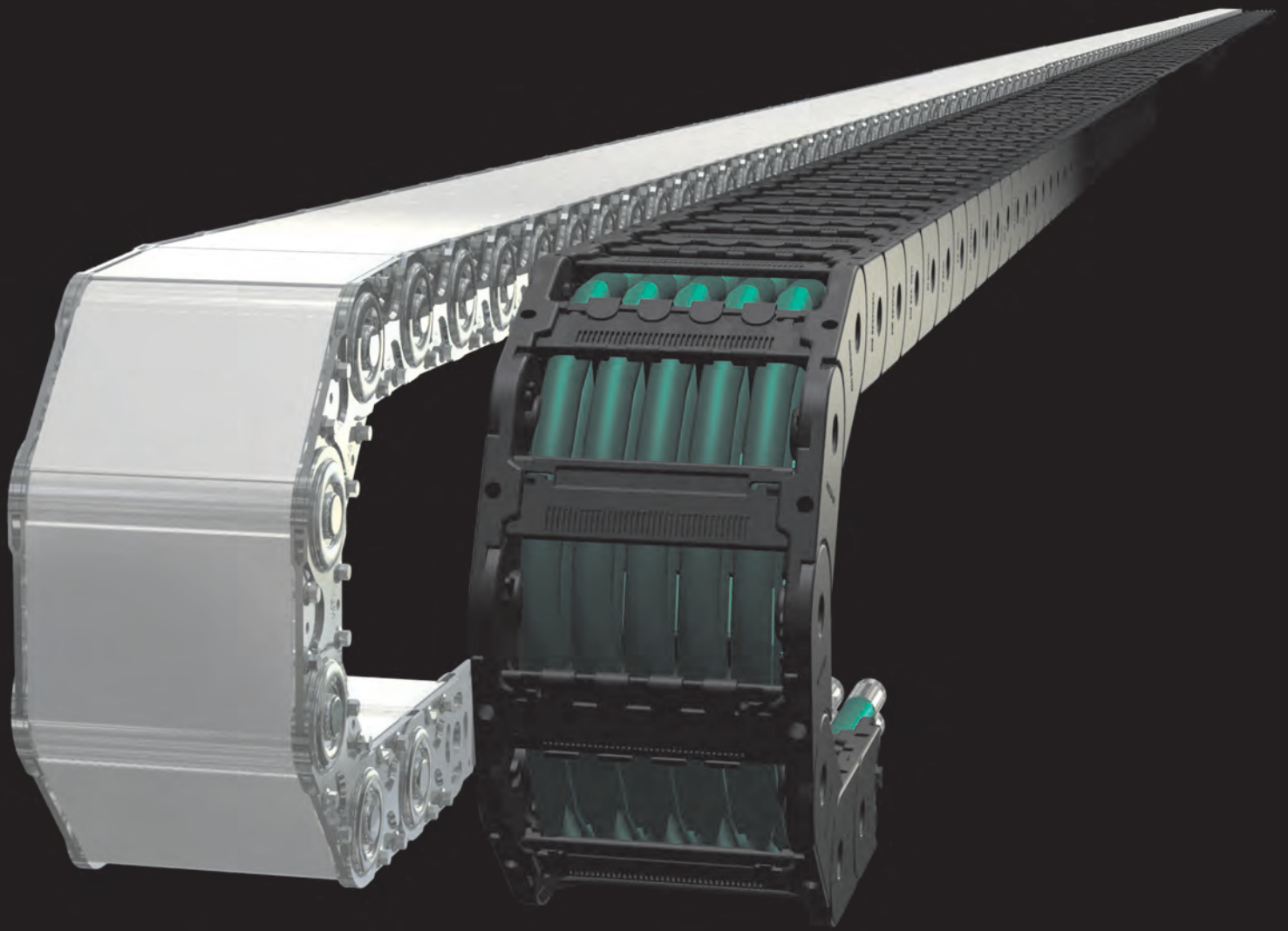

energy chains and
energy chain systems
in steel and plastics



EKD SYSTEMS is manufacturer of energy chains since 1970 and since 2022 a member of HELUKABEL GmbH. From the founding product energy pipe is formed today a wide range of energy chains and energy chain systems, which provides the standard of energy chains in steel and plastic up to plug in speciality products and tailor-made solutions with cables, connectors and mounting kits for every application. The service spectrum ranges from the selection and design of appropriate energy chains, electrical and hose lining to final assembly and commissioning on site.

In addition to standardized series products in steel and plastics special products are a priority of the ekd product range, which are designed and made of materials in accordance to customers requirements.

This product range contents the energy chain itself up to energy chain components and plug and play ready complete systems, which are named as energy chain systems.



The headquarter in Erkrath in plant 1 comprises the administration, the mold injection area with an attached tool manufacturing, machining centers, the final assembly and shipping area and the stock 1.

Further stocks and the manufacturing of assemblies and complete systems are organized in the adjacent factories.

The proximity and the organization of the individual process design and manufacturing areas in a certified Quality Management System (ISO 9001:2008) enable customer-oriented and fast processing of requests from the initial project outline to delivery - no matter whether standard or custom solutions.

Design guidelines	4		
Arrangements	8		
Wiring	11		
Strain reliefs	12		
Order informations	14		
Kolibri	18		
▪ applications	19		
▪ dimensions	20		
▪ types	21		
▪ sizes	22		
▪ height 10	23		
▪ height 15	24		
▪ height 22	26		
▪ height 30	28		
▪ height 40	33		
▪ height 50	35		
▪ height 65	37		
▪ parts	39		
▪ assembly	40		
▪ flanges	42		
▪ part numbers	44		
PKK	48		
▪ applications	49		
▪ dimensions	50		
▪ types	52		
▪ sizes	54		
▪ parts	55		
▪ assembly	56		
▪ part numbers	62		
PLE	66		
▪ applications	67		
▪ dimensions	68		
▪ types	69		
▪ sizes	71		
– PLE with inserts			
– PLP with plastic divider Pz			
– PLA with alu-slotprofile			
– PLS with foam stay			
▪ parts	72		
▪ assembly	73		
▪ part numbers	76		
SLE	80		
▪ applications	81		
▪ dimensions	82		
▪ types	84		
▪ sizes	86		
– SLE with inserts			
– SLP with plastic divider Pz			
– SLA with alu-slotprofile			
– SLS with foam stay			
– SLR with pipe- / rollstays			
▪ parts	87		
▪ assembly	88		
▪ part numbers	92		
▪ accessories	98		
GKA	100		
▪ dimensions	103		
▪ connectors	103		
▪ types	103		
▪ sizes	104		
▪ parts	105		
SFK	106		
▪ dimensions	106		
▪ connectors	107		
PFR	108		
▪ dimensions	108		
▪ connectors	108		
Troughs	110		
▪ gliding applications	113		
Energy chain systems	114		
System Marathon	116		
System Allround	118		
System Eltola	119		
System Reintec	120		
Materials	122		
Safety instructions	127		

DESIGN GUIDELINES

Selection of the energy chain and material

For most applications energy chains made of plastic is your first choice. Chemical resistance, light weight and low costs are the major advantages. Steel chains are used under extreme payloads and high mechanical or other particular requirements. For extreme cycles the hardened (carburized) steel is required to achieve long life.

Calculation of cross-section

First, the cross-section required for the wires is determined, and then specific motions or arrangements, aggressive environmental conditions or other factors lead to your selection.

A pre-selection of the product series may use the fields of application (see product series chapter).

All lines must be able to move freely in the energy chain. This requires an individual clearance to be taken into account for each line:

- round cable: 10% of the diameter
- flat cable: 10% of the cable width and height
- hoses: 20% of hose diameter

Optimum requirement is the separation of all lines by means of individual chambers. Especially with varying diameters or multi-layer wiring a separation by vertical and horizontal dividers is required.

If several lines are to be laid in one chamber, the chamber dimensions have to be restricted so that they maintain their relative positions.

Even multi-layer arrangements of flat cables have always to be separated with horizontal dividers.

When using pressure hose a change in length has to be taken into account through additional clearance in the chain bow (radius), which can be achieved by a corresponding chain height (a).

The distribution of the energy chain cross-section should be symmetrical in order to ensure a uniform load. In addition heavy lines are laid out close to the links to minimize the bending loads on the transverse bars.

Determination of the bending radius

The bending radius of the energy chain is determined by the minimum permissible bending radius of the cables and hoses, the available installation space and the polygon oscillation PA of the energy chain.

In general, a minimum bend radius of $10d$ is considered, where d is the largest existing line diameter. Cables with smaller minimum bend radii are available by some manufacturers.

The polygon oscillation PA influences the moving of an energy chain. A large bend radius at the same pitch results usually in a calmer movement of the energy chain.

The installation space must have a height of more than $2R + c$, where R is the set-radius and c is the link height of the energy chain. The real radius is the set radius $+0/-5\%$. The pretension of the energy chain should also be considered.

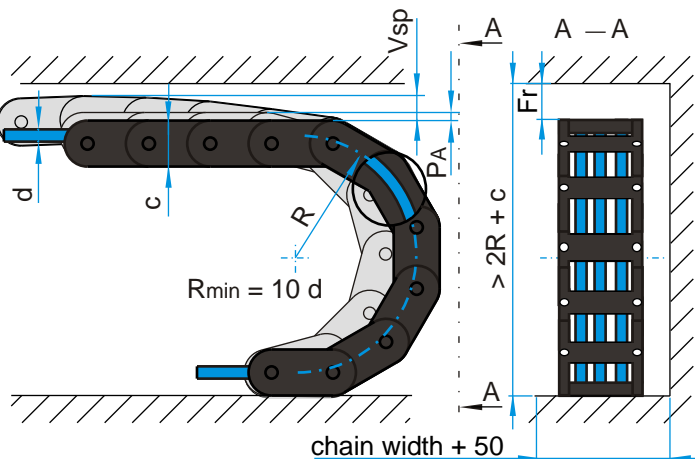
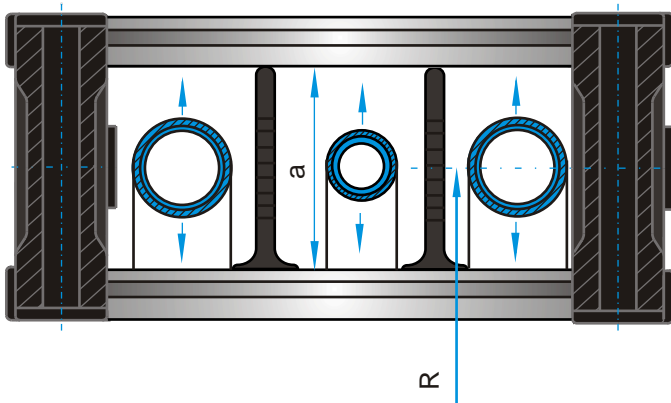
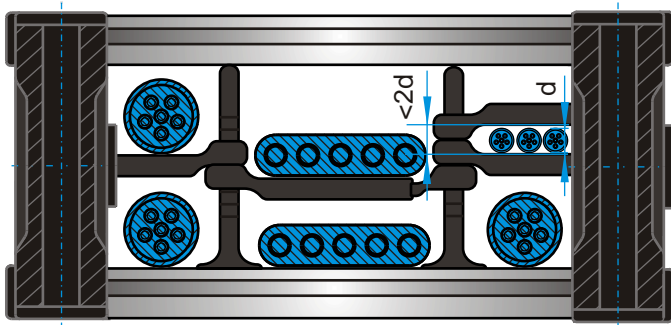
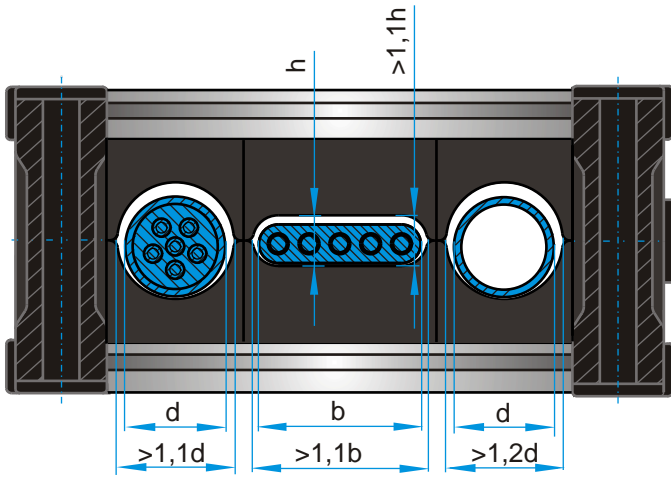

$$R = R_{set} +0/-5\%$$

$$Fr > 50 \text{ if } c < 70$$

$$Fr > 100 \text{ if } c > 70$$

Energy chain length

In standard applications the fixed connector of the energy chain is arranged in the middle of the travel distance. The moving connector moves horizontally over the fixed connector between the end positions of the travel. The required length of the energy chain between the first and the last pivoting link is then determined as follows:

$$L = \frac{LV}{2} + 4 R$$

- L length of the energy chain
- LV length of travel
- R bending radius of the energy chain

If the fixed connector is not in the middle of the travel, the energy chain has to be extended by a displacement of x:

$$L = \frac{LV}{2} + 4 R + x$$

- x offset of the fixed connector

After the selection of the energy chain, the length is rounded up to the link pitch. This length is the ordering length of the energy chain.

The connectors height is double bend radius plus link height:

$$HA = 2 R + c$$

- HA connector height
- c link height of the energy chain

Review of the free carrying length

The additional load is the weight of all cables and hoses, divided by the length of the chain:

$$ms = \frac{mL}{L}$$

- mL cable weight
- ms specific additional load

Thus with calculated additional load and the help of the load diagram the free carrying length of the energy chain can be verified.

If the additional load is too high for a particular chain an energy chain with greater free carrying length is chosen or constructive changes have to be done that allow the operation with the chosen energy chain (eg, gliding arrangement, support rollers, SYSTEM MARATHON or similar).

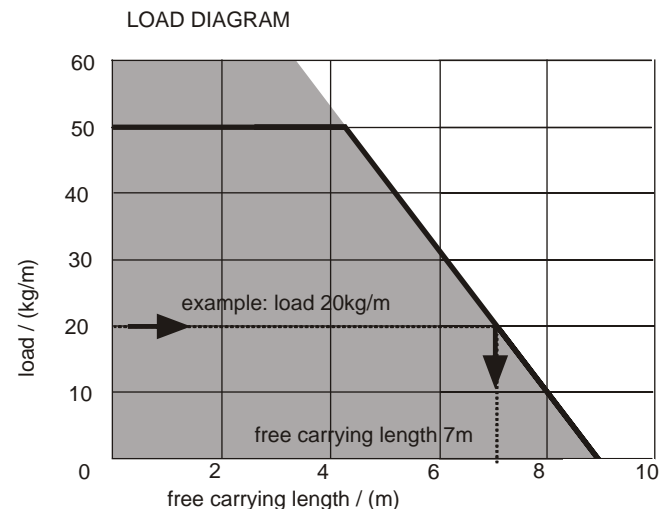
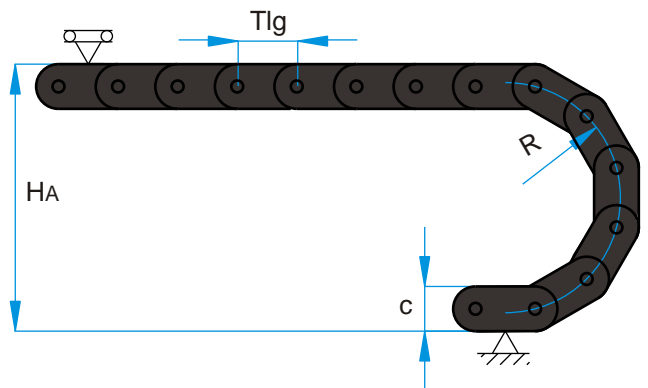
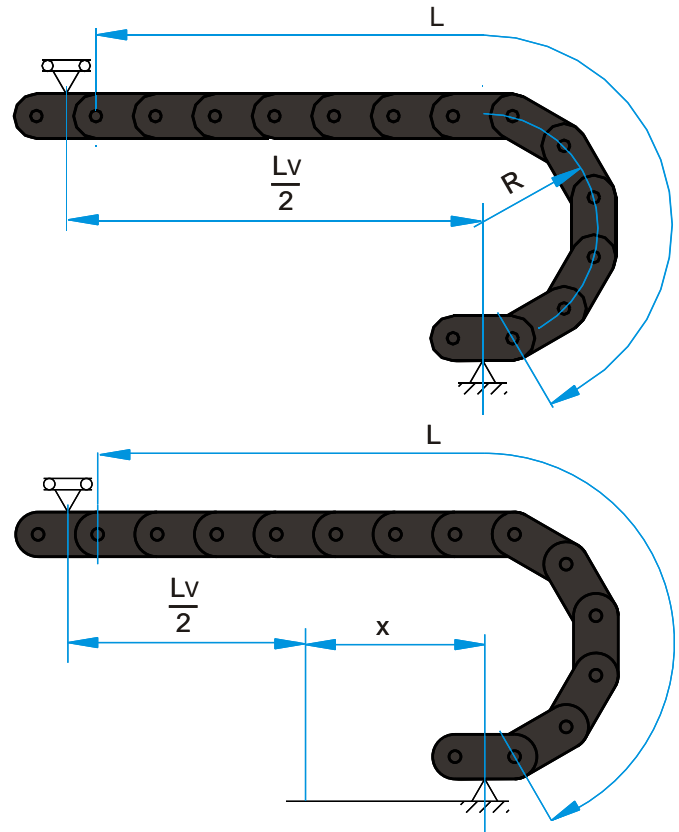

Pretension and permissible sag

ekd energy chains are supplied with pretension. Exceptions are energy chains for vertical or sliding arrangements as well as on the side lying energy chains, for example, in a circular arrangement.

The pretension is a manufacturing tool to achieve energy chains with increased free carrying lengths. The values for the pretension is set by the manufacturer. ekd energy chains made of steel are manufactured with 5 mm / m and plastic energy chains up to 25 mm / m as pretension with no load.

The sag is due to the additional load and the weight of the energy chain. Due to the significantly lower elongation of steel (0.2% linear elongation) compared to plastics the permissible sag of the steel chains is limited lower than for plastic energy chains.

On the other hand, the effect on plastic energy chains of a long-term static load with a long unsupported length of the upper strand chains will increase the sag (creeping of plastics).

Elevated temperatures and humidity increases this effect. The sag of energy chains is also increased by use-wear.

The maximum allowable sag can only be judged in the assessment of all operating conditions. Within the limits for the free carrying length specified in the load diagram the sag is within the permissible range at normal operating and environmental conditions.

In addition the following factors have to be taken into account:

Using toughs and slow moving energy chain sag is limited.

For high accelerations and high travel speeds too much sag is a problem. A defined force application at the moved connector is not guaranteed and uncontrollable chain oscillations can occur. Thus the energy chain material is subjected to extreme dynamic stresses. In such cases, corrective steps should be taken.

The first step is the selection of an energy chain with increased free carrying length. If this can not be done, these are the following alternatives:

Support rolls and support rails

Support rollers can increase the maximum travel L_v of steel chains by up to four times the free carrying length L_f . With additional support rollers and a support rail the maximum range of movement can be expanded up to eight times the free carrying length.

The use of support rollers with support frames, is limited to speeds below 1 m/s.

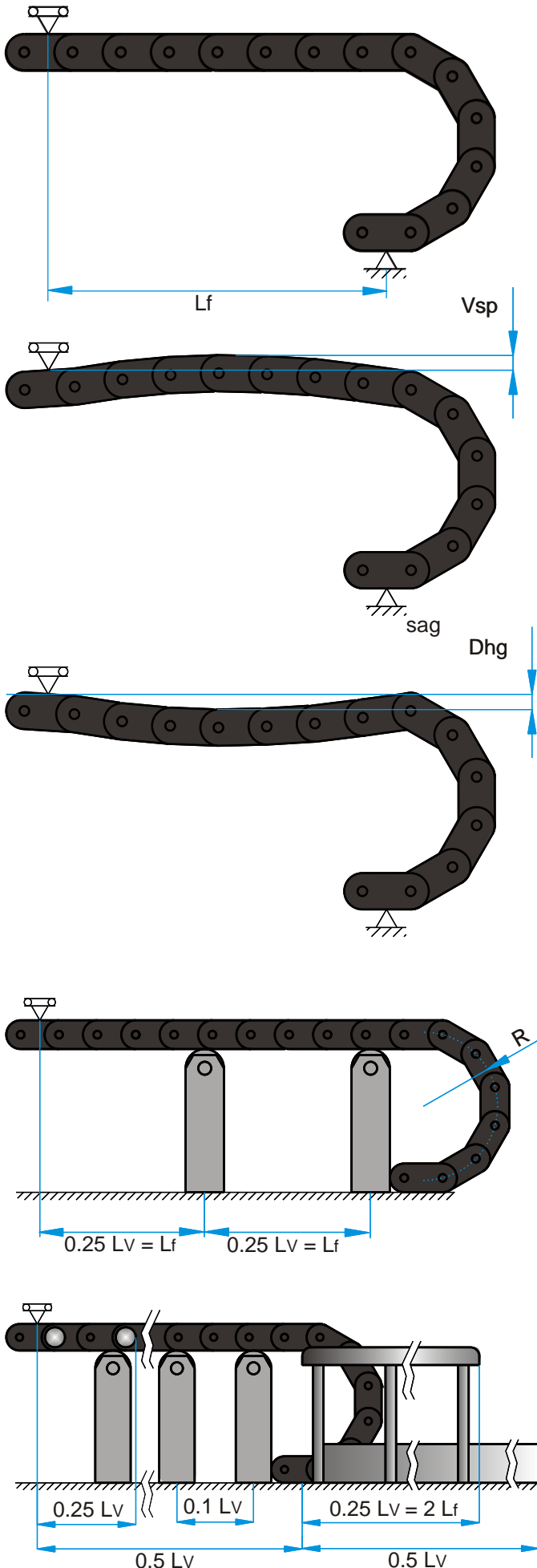

Raised trough

This type is mainly used with plastic energy chain applications. As with the use of support rolls the maximum travel can be increased up to four times the free carrying length.

Because of the larger permissible sagging, support rolls are not suitable for plastic energy chains.

Support carriage

For long travel distances and high additional loads support carriages can be used with reverse travelling energy chains. The side-mounted support rolls carry the energy chain and move the support carriage.

The energy chains now only face pull forces and through this an extremely long life is achieved even at high additional loads.

SYSTEM MARATHON

The patented SYSTEM MARATHON for unlimited travel is also designed for high speeds and high accelerations. The upper run is running with supporting rollers over the entire travel on continuous flat rails and the rollers swing in the radius to lay down the energy chain at the bottom profile. In the back movement the rollers swing out again and lead the energy chain without wear over the entire travel. The SYSTEM MARATHON is not dependant upon the type of energy chain and therefore steel energy chains are as equally suitable as plastic energy chains.

Gliding energy chains

Gliding energy chains require guiding the upper run in a continuous trough. In addition, the first half of travel slide bars are mounted on the energy chain is extended via the fixed end in the middle of the travel out up to the starting point to create a continuous gliding plane (see also chapter troughs).

With high dynamic demands on the energy chain, lowering the moving connection end may be necessary to result in a better introduction of push forces into the energy chain.

In travels over 30 m, velocities above 1.5 m / s and acceleration of 1 m/s² lowering the moving end is recommended and requires an additional length of the energy chain. Chain links with an opposite bend radius minimize the required additional length and minimize oscillations of the remaining free carrying length of the energy chain.

PKK, PLE and SLE energy chains for gliding arrangements are preferably equipped with sliders that can be replaced after reaching the wear limit without dismantling or replacing the energy chain.

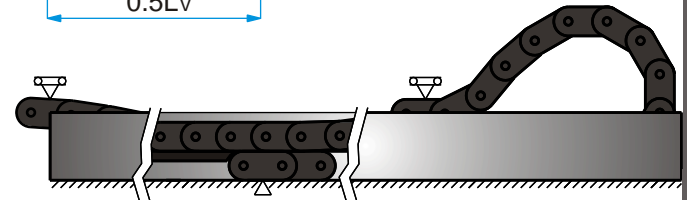
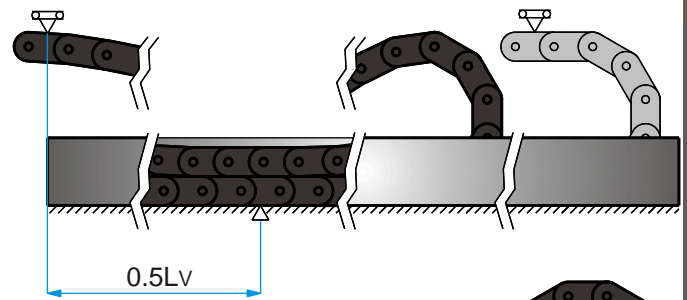
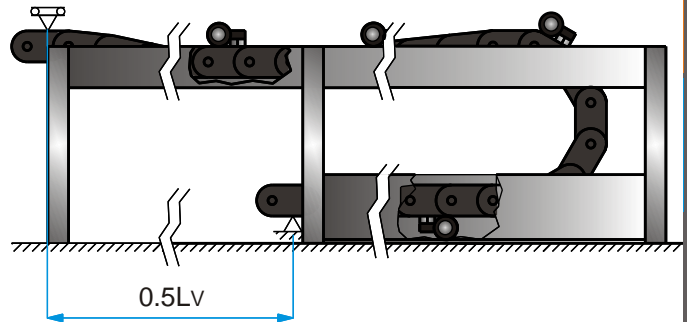
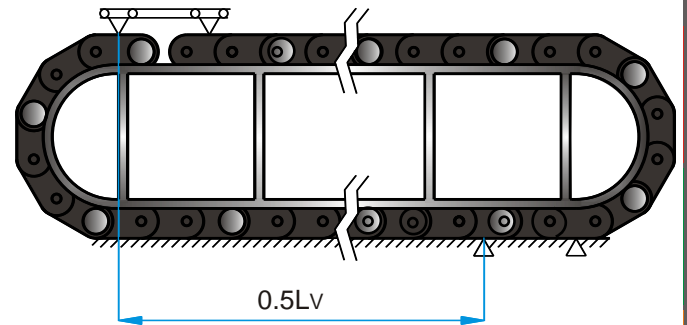
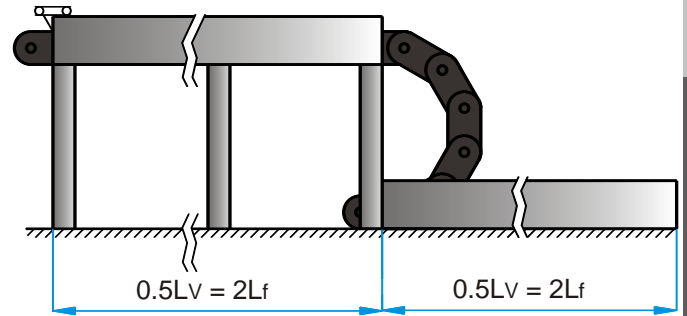

B = moving connector
 F = fixed connector
 normal
 (not specified in order)

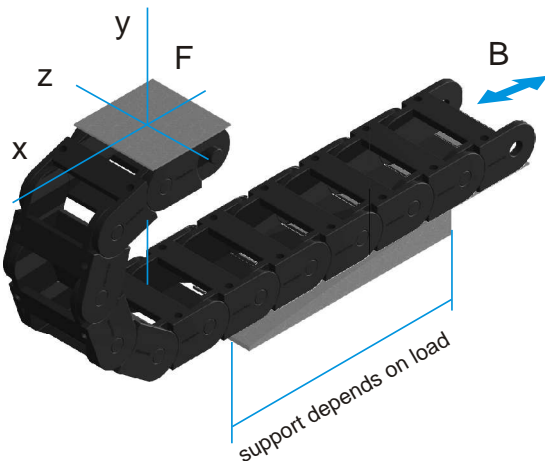
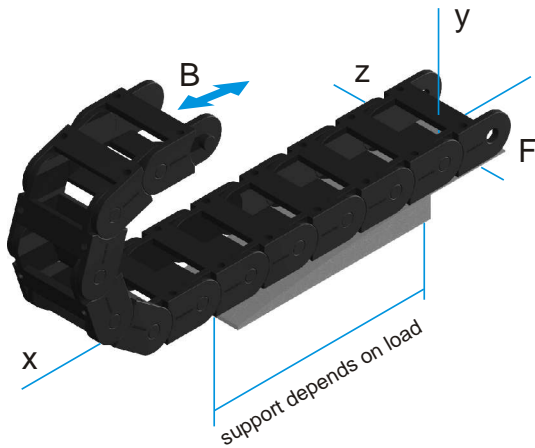
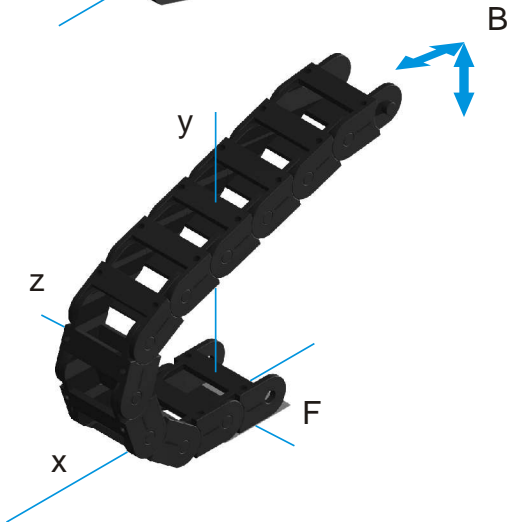
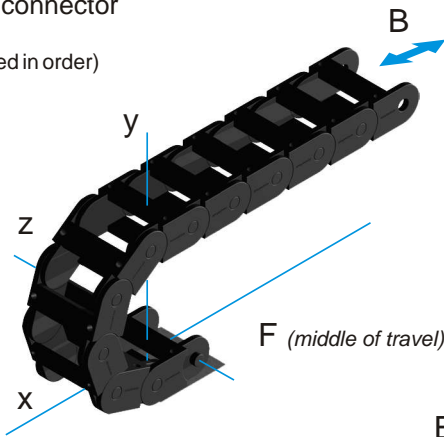

ARRANGEMENTS

normal arrangement (n)

In the **normal** arrangement the fixed connector is usually on the first link in the lower strand in the middle of the travel. The moving end connector is moving the chain in a straight line lengthwise at a height of $2R+c$ over the entire travel. The upper strand is steadily reduced through the bending of the individual links until the whole chain length is taken to the bottom or in a trough. This arrangement allows maximum speeds and extreme acceleration with optimum durability.

multiaxial (m)

In the **multiaxial** arrangement is a vertical and horizontal motion of the driver along the x-axis (travel direction) and one or more movement in the y- or z-direction. While running in the y-direction may be done by any conventional energy chain, the movements in the z-direction require the energy chain system ALLROUND.

free overhang (f)

In contrast to the normal arrangement the freely exceeding lower strand is supported only partially by a substructure. Due to the high weight load on the lower strand in this arrangement only significantly reduced travel distance is possible.

moved end downside (u)

If the driver is positioned in the lower, due to the heavy weight only a reduced travel distance is possible (see above).

nested travel (i)

The arrangement of two or more energy chains with different bending radii or even different energy chains makes sense when using a variety of cables and hoses together. The energy chains are moved together by a common driver.

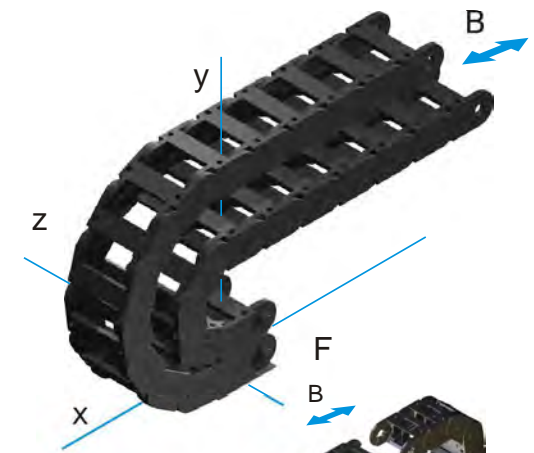

opposite running (g)

Opposite running means two energy chains running in one line synchronously or independent of each other. It is a further possibility to raise the number of moved lines without increasing the necessary space.

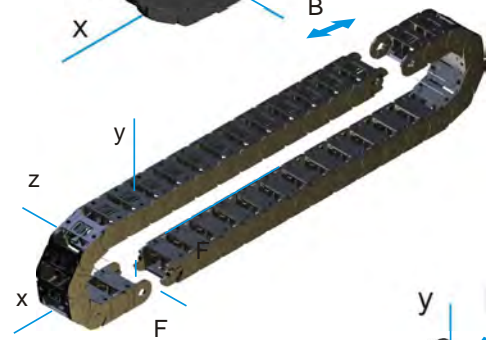

gliding arrangement (l)

If the free carrying length is exceeded, the energy chain changes into a gliding state. In this arrangement, use energy chains without pretension. A trough is required (see chapter troughs). Sliders increase the lifespan and can be replaced if necessary.

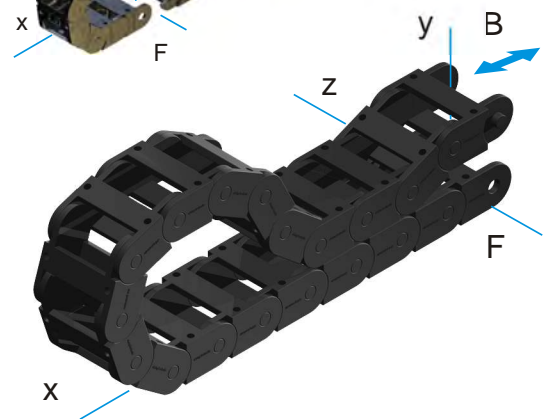

vertical travel (s)

Vertical travel arrangements are often installed in systems in which multiple linear axes are coupled. In this arrangement usually energy chains without pretension are used. Vertical arrangement with multiaxial movement needs chains with pretension.

The weight of the lines and of the energy chain has to be placed and pushed by the straight part of the chain. This forces should be caught by a supporting.

The energy chain should be arranged so that optional cross accelerations are in the y-direction

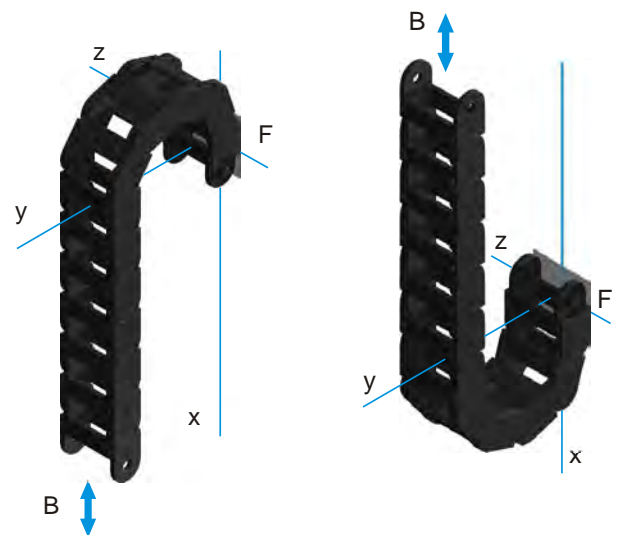

vertically hanging (h)

Elevators, high-bay stores and doors are typical applications for energy chains in vertically hanging arrangement. In this arrangement the energy chain is predominantly tensile stressed. Lateral acceleration should be layed if any, in the y-direction. Energy chains are without pretension.

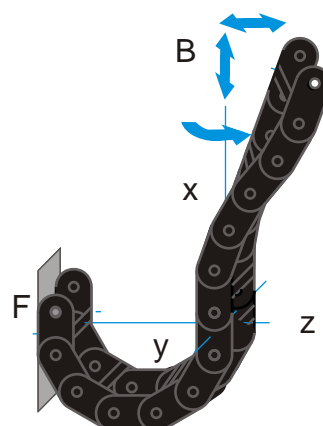

hanging multiaxial (hm)

The energy chain ALLROUND provides the combination of linear and rotary motion.

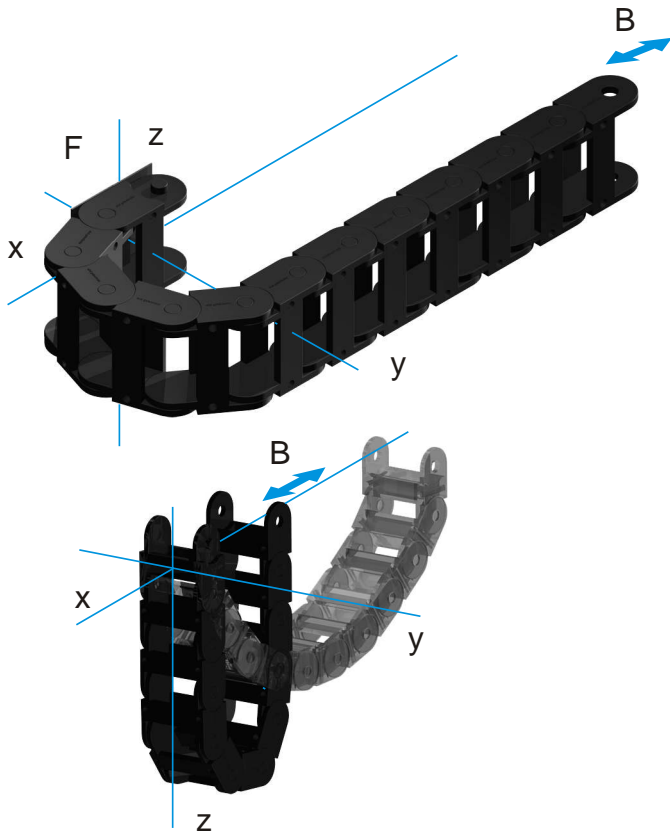

horizontal (w)

on the side

Energy chains are arranged horizontally lying on their side, for example, if the space does not allow a normal arrangement. In some cases, lying on its side provides an alternative for very long traverse at low speeds and strokes. In this application mainly chains without pretension are used.

In general, suitable guide troughs and gliding discs or rollers are required.

driving apart (a)

With energy chains moving apart the calculation of the energy chain length does not follow the usual pattern, but be adapted to the individual requirements of the application.

circle (k)

on the side

The circular motion is a special form of chain movement. For circle movement a part of the energy chain has to be manufactured with an opposite bending radius R2.

The outer radius R3 is derived from the link height, the bending radius of the energy chain R1 and the opposite radius R2.

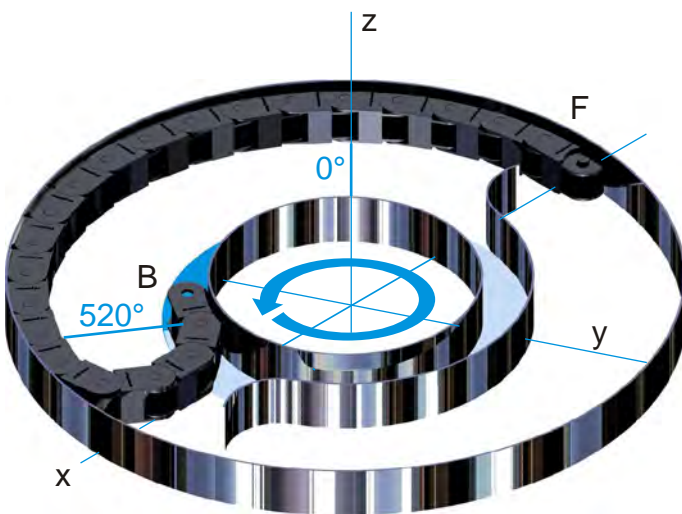
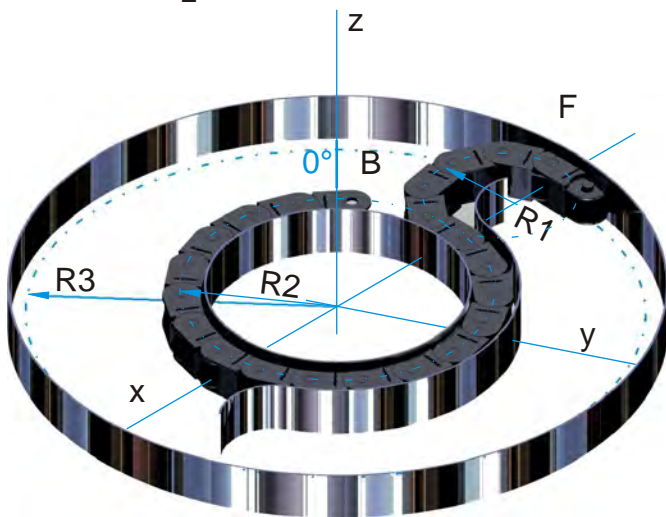

This type of horizontal arrangement allows rotation up to 520°. A customized guide channel is required.

For laying in energy chains only highly flexible cables with permissible bending radii and sufficient dynamic capacity suitable. The cables have to be laid twist free to move freely lengthwise. Cable on a reel should be unrolled in the reverse winding direction and placed in the extended state in the energy chain. For intermediate storage the lines are ideally laid out straight. The material relaxation occurs in this case facilitates a twist-free installation.

The distribution of the chain interior must prevent mutual interference between the wires with dividers or wrap clamping of different diameters safely, so that each line can move freely in the longitudinal direction (see design guidelines). In particular in the energy chain radius tensile stressed wires increase wear drastically and reduce the reliability. A fixation of the wires or a bundle of several lines using cable ties or the like within the energy chain can also cause damage.

Strain Relief

With long travel distances and high speeds the cables should be attached with strain relief only at the driver end. For free carrying energy chains recommend for aesthetic reasons, a strain relief on both ends. The distance of strain relief to the bending stressed area depends on the particulars of the line manufacturer. Hydraulic hoses have special needs. Special requirements apply to hydraulic and media hoses. Appropriate jacket material and the structural design are crucial for hydraulic hoses. The minimum bending radii specified by the manufacturer must be observed. If the hoses are fixed on both sides in the longitudinal direction of the chain, the hose line lengths may only be manufactured with minimal tolerances.

Integrated strain relief

In this space-saving type the strain relief is directly attached to the plastic dividers (PZ) in the first link of the energy chain (note the mounting direction of PZ!).

In order to avoid premature line wear caused by dynamic loads, a small excess length of the chain is recommended.

Combined strain relief

The combined strain relief combines the advantage of a sufficient distance from the bending line areas to the strain relief by the simple and space-saving installation of the integrated strain relief. The anchor profile is provided to the drilling dimensions of the energy chain and attached to the chain.

The lateral insertion and extraction of strain relief elements is through the C-profile.

Separate strain relief

The separate strain relief is recommended for high dynamic loads and large line diameters. A sufficient distance of the strain relief to the moved line areas and length compensations are easy to implement. In this variant the lateral insertion and extraction of the strain relief elements with no installation work on the cable carrier is possible.

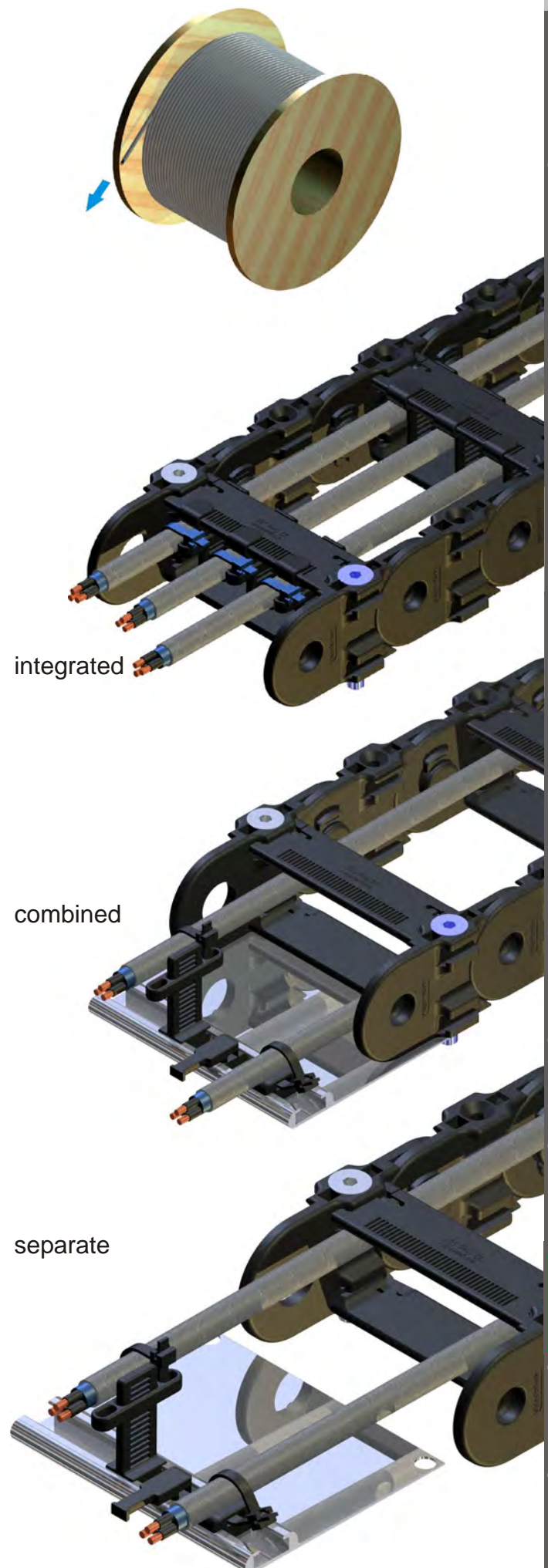

ZLP XX part no. 1163
(xx = chain width)

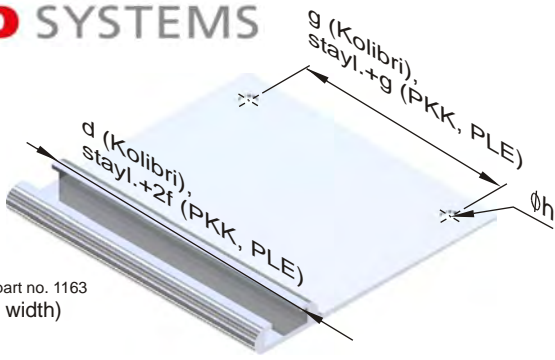

anchor profile ZLP

The aluminum anchor profile is used to mount various strain relief elements. Both the distance to the energy chain as well as the positioning of the strain relief elements can be easily designed. The length of the anchor profile and the drilling dimensions are determined by the dimensions of the energy chain.

strain relief stay ZLS

The strain relief stay was developed for anchoring the blue ribbon and the cable anchor. The design of the strain relief stay is closely based on the plastic divider (PZ). It is installed laterally into the anchor profile or a commercially available C-profile and can add several strain relief elements through the stay.

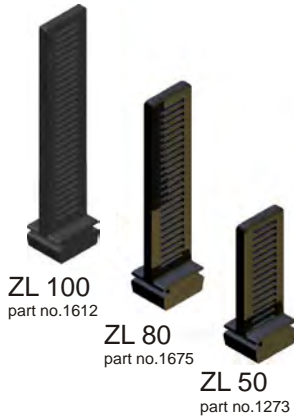

ZLB24 part no. 1142

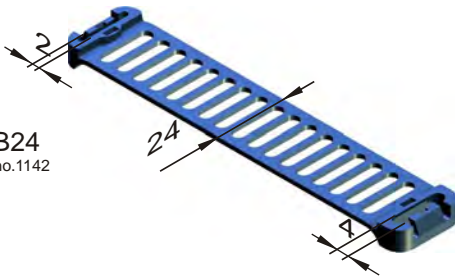

Ø7 < D < Ø35

blue ribbon ZLB 24

The Blue Ribbon is a special ekd cable tie with a 24 mm wide cable mounting. The Blue Ribbon can be locked on the strain relief stay or the plastic divider (2mm, 4mm). Cables with diameters of 7 mm up to 35 mm can be fixed single or multiple (s-shaped) with the Blue Ribbon.

ZLA8 4 part no. 1159

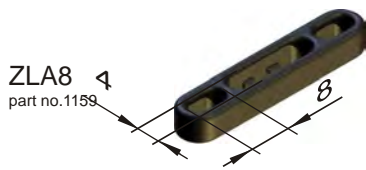

cable anchor ZLA 8

Connect the lines with standard cable ties to the cable anchor (single or double slide) and push on the plastic divider.

A multi-layer connection of wires with this is as easy as possible, with the simple removal to carry out maintenance work.

ZLS10 part no. 1160

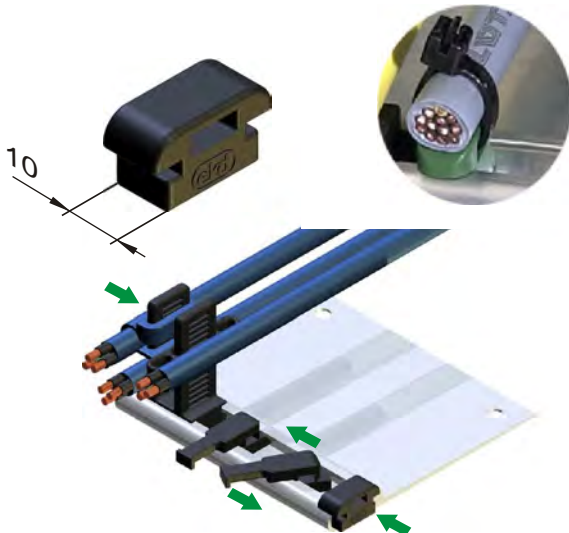

sliding anchor ZLS 10

The line is mounted with commercially available cable ties at the sliding anchor which is inserted into the aluminum C-profile. The simple movement of the sliding anchor provides a generous assembly space.

horn stay ZHS 10

The horn stay ZHS10 is transversely inserted into the anchor profile and locked by a 90 ° rotation. It is therefore permanently positioned in the anchor profile. The line is mounted with cable ties at the horn stay.

The horn stay HS 65 and HS 85 are components of the integrated strain relief for the rigid version of the chain series Kolibri. HS 55 and HS 75 are for the standard versions of the chain series Kolibri. For the series PKK the horn stay HS 220 and HS 320 deliverable.

The horn stays are attached to the stay of the chain connecting link.

ZHS10
part.no.1407

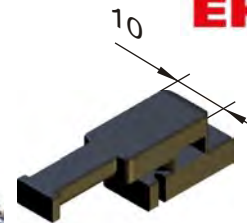

HS65
part.no.1503

HS85
part.no.1504

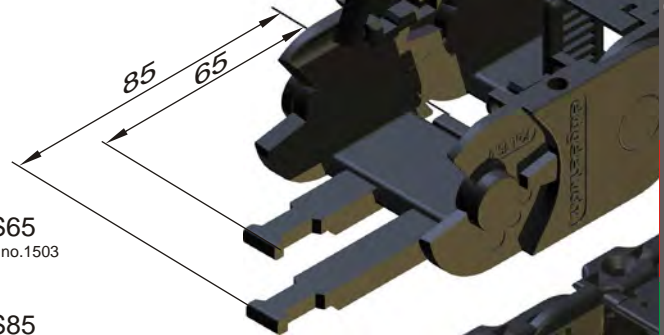

yoke clamps

Commercial yoke clamps can be used as a separate strain relief and are mounted with the aluminum C-profile of the SLE 520 or SLE 320 in front of the energy chain connectors.

As an integrated strain relief they are inserted directly into the first and last chain link of the SLE and PLE.

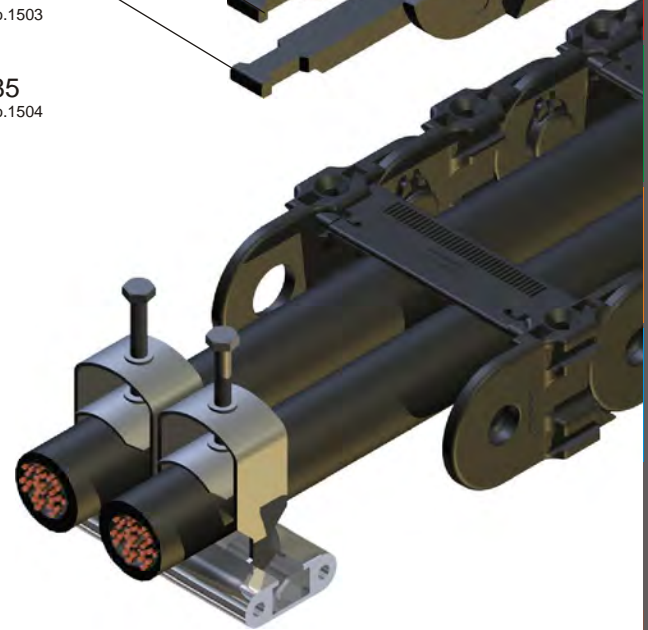

General operating and safety instructions

Energy chains are technical products which are designed and sized as part of an engineering-design according to a specific use. Dealing with this products in accordance with the generally recognized rules of operating and safety rules have to be followed in dealing with these products. Observe the accident prevention regulations. Additional requirements, such as when operating in hazardous areas are to take into account.

Electrical conductiv energy chains have to be grounded in every case.

Proper use requires the observance of the dimension limits of the energy chains. The following experiences from practice shows errors can lead to significant functional impairment or damage of energy chains:

- Improper handling of the energy chain for transport and assembly due to weight load of the energy chain, especially an unsupported application.
- Contamination from such items as coarse shavings can cause damage to zour lines.

If this can not be avoided in the operating in abrasive conditions such as abrasive dust entry or vibrations, so trough appropriate design and inspection intervals, particularly in unsupervised, automated operating systems to avoid unexpected machine failure.

The order for ekd energy chain includes the following information:

The energy chain selection is based on the diameter and number of cables to be laid. A clearance of at least 10% for cable and 20% for hoses should be available. The choice of plastic or steel energy chain, and between open and closed design and operating conditions.

The radius is also dependent on the cables to be installed. Comply with the specifications of the manufacturer. 10 times the largest line diameter can be a general rule.

The length of the chain depends on the travel distance. The following formula can be used:

$$L = \text{travel distance} / 2 + (4 \times \text{radius}) \text{ (round up to link pitch)}$$

Kolibri, PKK and PLE energy chains can be supplied with additional connector links (see figure below).

The width of the chain depends on the number and dimension of the cables to be installed. With slow applications cables can be installed on top of one another, creating extra space.

ekd plastic energy chains with integrated connectors need no additional connector parts. In case of special connector constitutions the order text lists first the fixed connector then the moving connector

The arrangement is only to be stated in special cases.

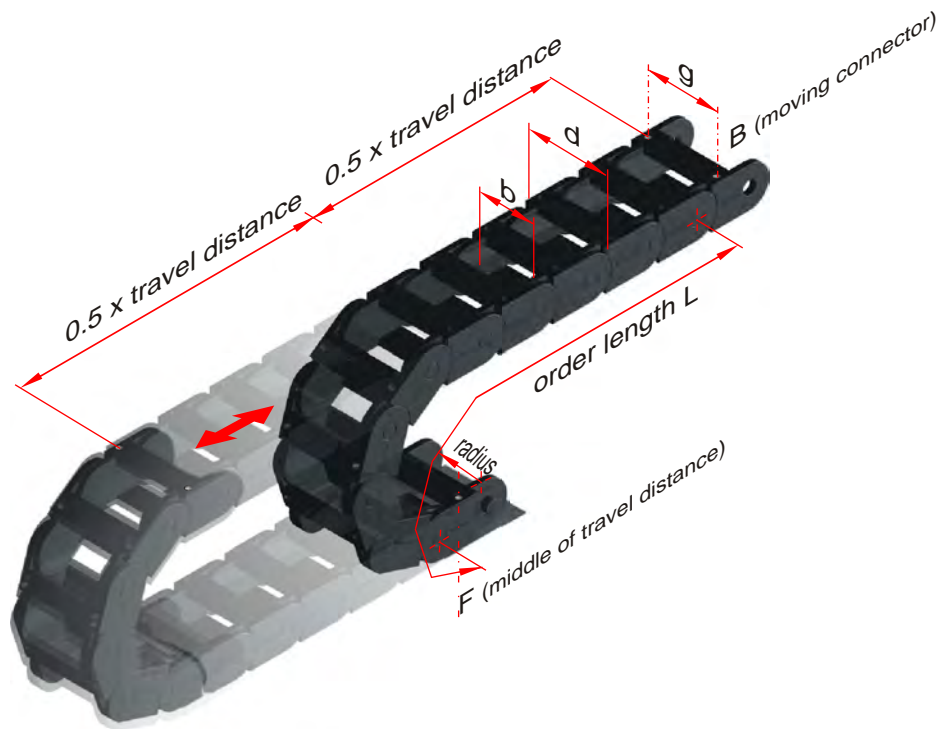

order examples:						
energy chain	/ radius	X length	/ width	/ connectors (F/B)	arrangement	stay distribution
Kolibri 30.095.0	/ 75	X 2170				
PKK 220	/ 200	X 2340	/ 200		"h"	;5 Pz, 1PT55
PLE 220	/ 200	X 2325	/ 200		"u"	;5 Pz, 1 Pt55
SLE 220	/ 200	X 2325	/ 200	- D/E		n.Z.
GKA 160	/ 1000	X 8775	/ 660	- D/E		n.Z.
SFK 32N	/ 250	X 3000		- A/N	"h"	
PFR 223	/ 200	X 3200		- K/K		

ORDER EXAMPLES

Kolibri 30.095.0 (standard type, pitch 35 mm), normal arrangement, bending radius R75, travel $s = 3.680$ m:

$$s/2 + 4R = 3.680\text{mm}/2 + (4 \times 75\text{mm}) = 2140\text{mm}$$

$$2140\text{mm}/35\text{mm} = 61.14 \Rightarrow 62 \text{ chain links}$$

$$62 \times 35\text{mm} = 2170\text{mm} = \text{order length } L$$

The energy chain is mounted via the integrated connector. An interior separation is not necessary.

order text:
pos 1: 1 pcs. Kolibri 30.095.0 / 75 x 2170

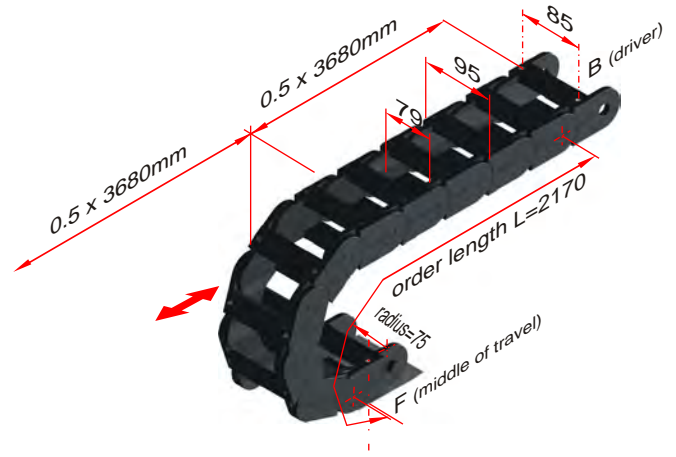

PKK 220 bending radius R200, travel 3.00m, inner width 200 mm (stay length 200), the chain is assembled hanging, inner separation through 5 PZ (movable) and 1 PT 55 in every 2. chain link.

A strain relief of the lines has to be installed bilateral with anchor profile, strain relief stays, cable anchors and sliding anchors.

$$s/2 + 4R = 3.000\text{mm}/2 + (4 \times 200\text{mm}) = 2300\text{mm}$$

$$2300\text{mm}/65\text{mm} = 35.38 \Rightarrow 36 \text{ chain links}$$

$$36 \times 65\text{mm} = 2340\text{mm} = \text{order length } L$$

order text:
pos.1: 1 pcs. PKK 220 / 200 x 2340 / 200 "h"; 5 PZ (movable), 1PT55, in every 2.link
pos.2: 2 pcs. ZLP 230 mit 7 ZLS 10, 2 ZL50, 2 ZLA 8

separation:

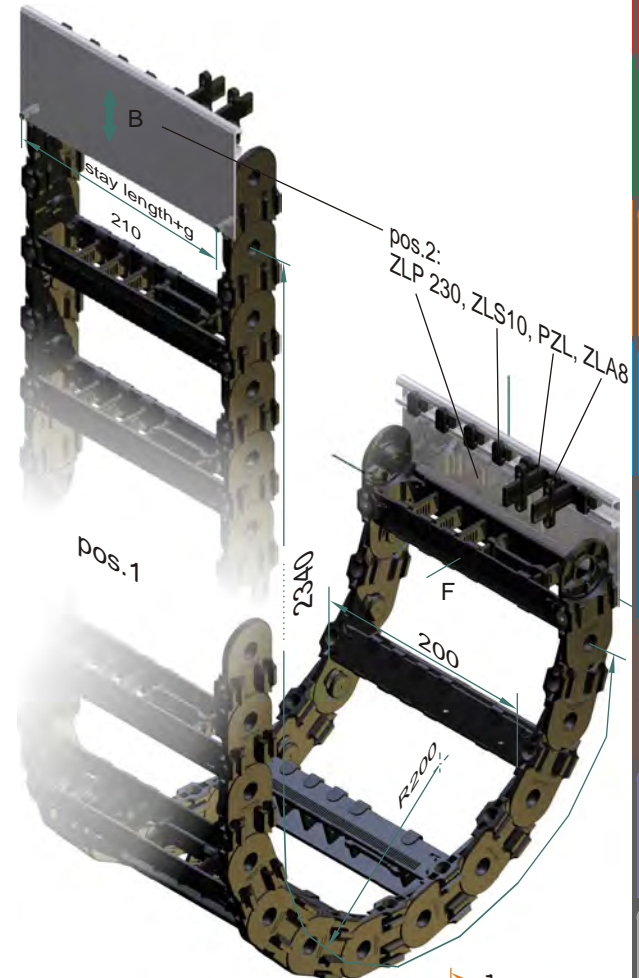
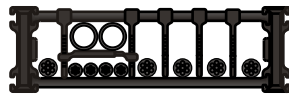

PLE 320 bending radius R100, travel 1.00m, inner width 100 mm (stay length 100), bottom driver, plastic inserts according to drawing no. xy in every chain link. A strain relief should be installed by the customer

$$s/2 + 4r = 1.000\text{mm}/2 + (4 \times 100\text{mm}) = 900\text{mm}$$

$$900\text{mm}/100\text{mm} = 9 \Rightarrow 9 \text{ chain links}$$

$$9 \times 100\text{mm} = 900\text{mm} = \text{order length } L$$

order text:
PLE 320 / 100 x 900 / 100 "u"; inserts acc. dwg. no.xy

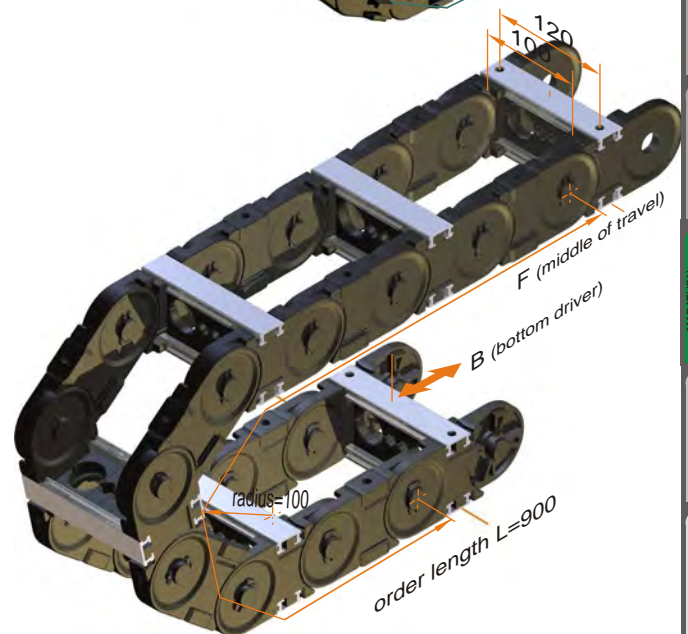

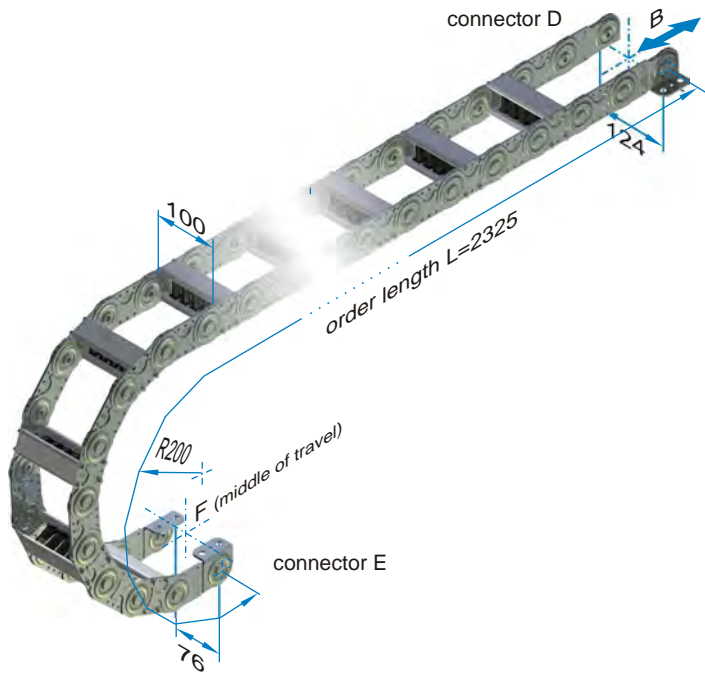

SLP 220 (SLE standard type with plastic inserts), pitch 75 mm, bending radius R200, travel $s = 3.00\text{m}$, inner width (=stay length) 100 mm, normal arrangement. The energy chain is mounted via connector D and E. A separation is done by 5 PZ in every second chain link:

$$S/2+4R = 3.000\text{mm}/2+(4 \times 200\text{mm}) = 2300\text{mm}$$

$$2300\text{mm}/75\text{mm} = 30.66 \Rightarrow 31 \text{ chain links}$$

$$31 \times 75\text{mm} = 2325\text{mm} = \text{order length L}$$

order text:
pos 1: 1 pcs. SLP220/200x2325/100-E/D;5 PZ

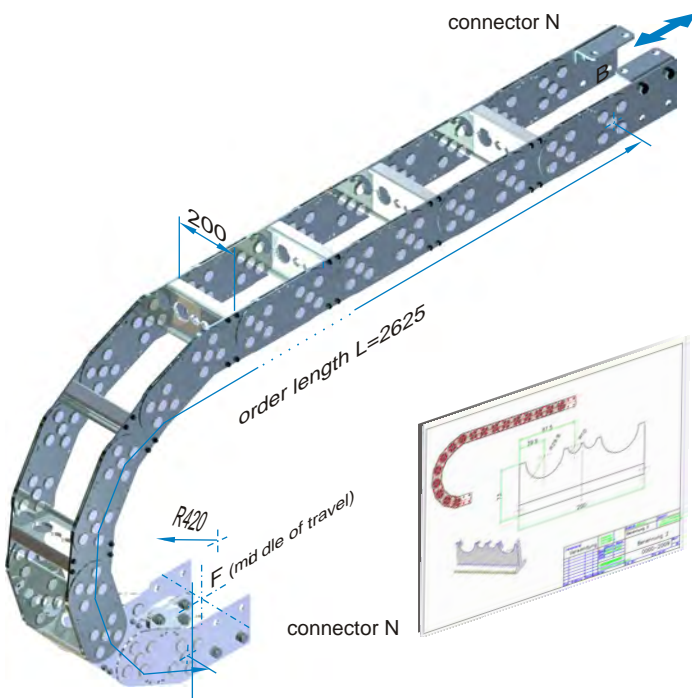

GKA 110 (GKA standard type with aluminium stays), pitch 175 mm, bending radius R420 (minimum polygon), travel $s = 1.80\text{ m}$, inner width (=stay length) 200 mm, normal arrangement.

The chain is mounted on both sides with connector N (connector N). Separation and adapted bending radius are according to drawing.

$$S/2+4R = 1800\text{mm}/2+(4 \times 420\text{mm}) = 2580\text{mm}$$

$$2580\text{mm}/175\text{mm} = 14.74 \Rightarrow 15 \text{ chain links}$$

$$15 \times 175\text{mm} = 2625\text{mm} = \text{order length L}$$

order text:
pos 1: 1 pcs. GKA 110/420x2625/200-N/N according to dwg. no. 0000/2009

For energy chains type GKA choose the order length as uneven multiple of the pitch.

ORDER EXAMPLES

SFK 22H, bending radius R150, travel s = 3.00m, inner width 80 mm, inner height 56 mm, normal arrangement. The energy chain is mounted with connector N on both ends.

$$S/2+4R = 3.000\text{mm}/2+(4 \times 150\text{mm}) = 2100\text{mm}$$

$$2100\text{mm} = \text{order length } L$$

order text:
pos 1: 1 pcs. SFK 22H/150x2100-N/N

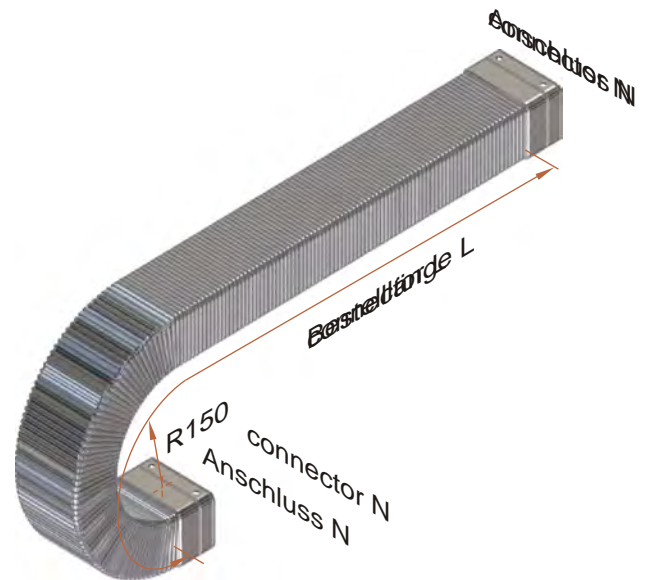

PFR 122, pitch 35 mm, bending radius R75mm, travel s = 0.31 m, inner width 38 mm, inner height 50 mm, normal arrangement.

The carrier is mounted via connector A and connector B.

$$S/2+4R = 310\text{mm}/2+(4 \times 75\text{mm}) = 455\text{mm}$$

$$455\text{mm}/35\text{mm} = 13 \text{ chain links}$$

$$13 \times 75\text{mm} = 455\text{mm} = \text{order length } L$$

order text:
pos 1: 1 pcs. PFR 122/75x455-A/B

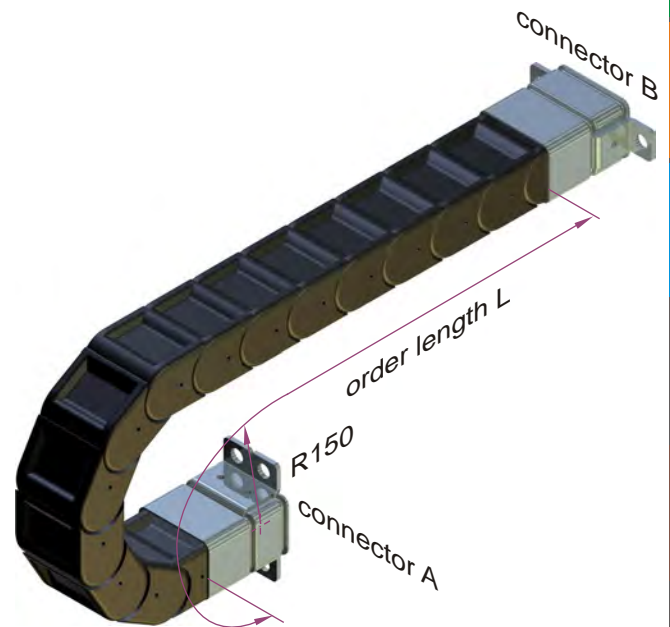

Kolibri 40.062.0 ELTOLA, pitch 45 mm, bending radius R100, travel s = 0.64 m, normal arrangement. The chain is mounted via the integrated connectors.

$$S/2+4R = 640\text{mm}/2+(4 \times 100\text{mm}) = 720 \text{ mm}$$

$$720\text{mm}/45\text{mm} = 16 \text{ chain links}$$

$$720\text{mm} = \text{order length } L$$

order text:
pos 1: 1 pcs. Kolibri 40.062.0/100x720 ELTOLA

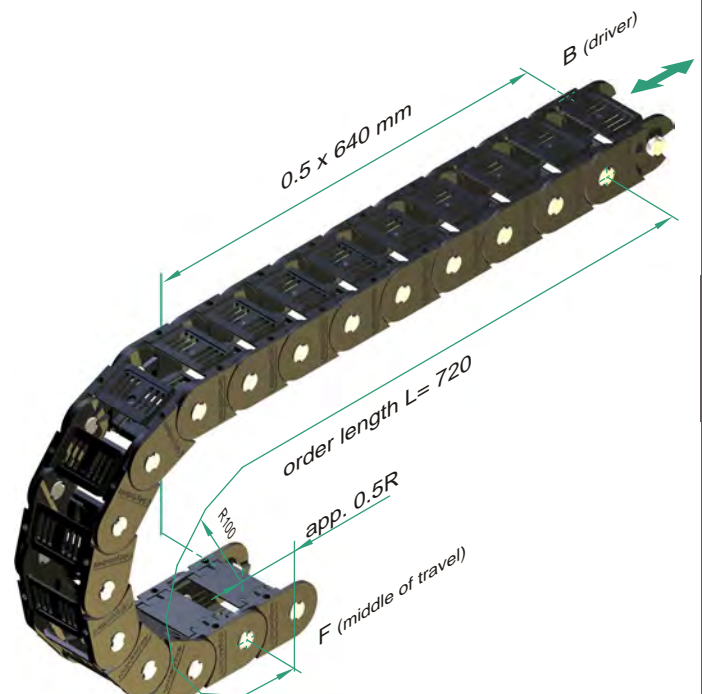

Kolibri

- Kolibri applications 19
- Kolibri dimensions 20
- Kolibri types 21
- Kolibri sizes 22
- Kolibri height 10 23
- Kolibri height 15 24
- Kolibri height 22 26
- Kolibri height 30 28
- Kolibri height 40 33
- Kolibri height 50 35
- Kolibri height 65 37
- Kolibri parts 39
- Kolibri assembly 40
- Kolibri flange connect. 42
- Kolibri part numbers 44



closed + open

The inexpensive energy chain for light-weight applications. The patented opening offers high rigid torsion behaviour and comfortable handling in one.

- easy access by flap stays
- extremely rigid and wear resistant
- unique separation with the pinch stay
- smallest dimensions

All ekd plastic energy chains are equipped with integrated connectors. Additional mounting parts are not needed.

Dimensions

bending radii:	15	to	400 mm
inner height:	7	to	50 mm
inner width:	7	to	195 mm
weight:	0.06	to	2.7 kg/m

Travel distance

The maximum travel distance is given by the arrangement and the load (weight of the lines). At normal arrangements the maximum travel distance is double the free carrying length. Support rollers or similar equipment may exceed this value.

In gliding arrangements travel distances up to 100 m are possible (according to the application).

For longer travels see chapter on design guidelines.

Travel speed

There are no limits for the travel speed in general. But with gliding arrangements application specific influences have to be taken into account.

Acceleration

There are no limits for the accelerations, in general. Limits may occur through the tensile stresses at high line weights.

Temperature

Long term temperature limits are between -20°C and 100°C.

Special variants

ELTOLA	... silent running
ATEX	... EX-protection
ESD	... antistatic
V-0	... self extinguishing

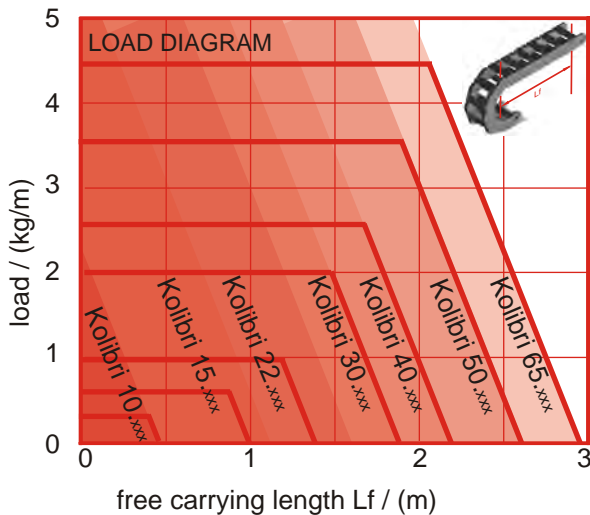

APPLICATION AREAS

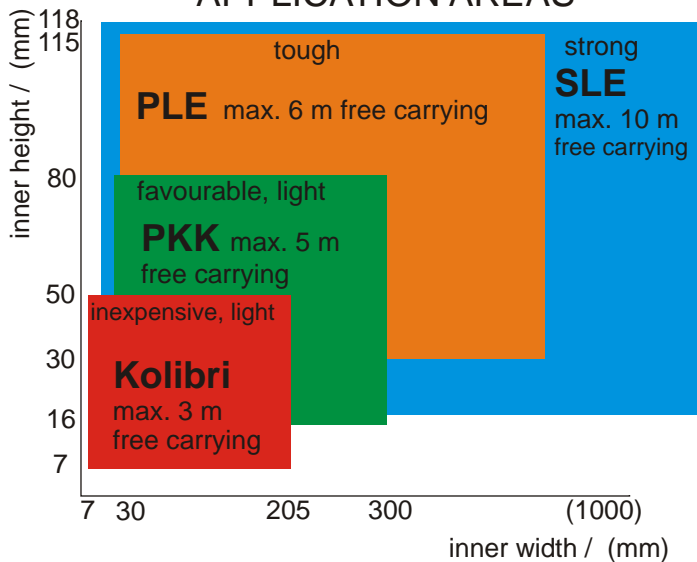

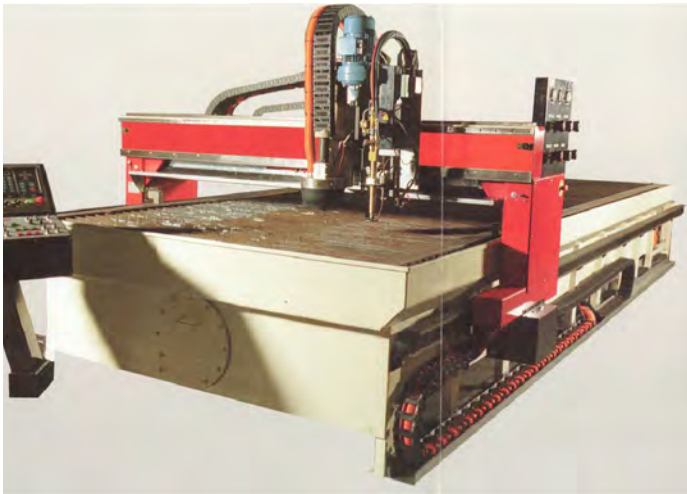
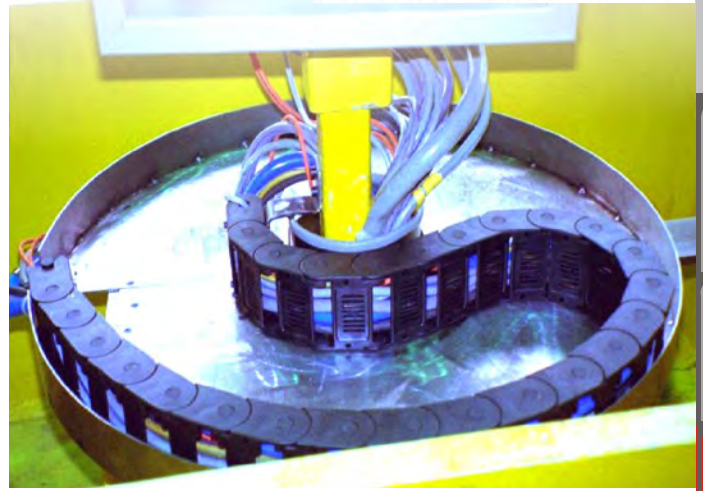
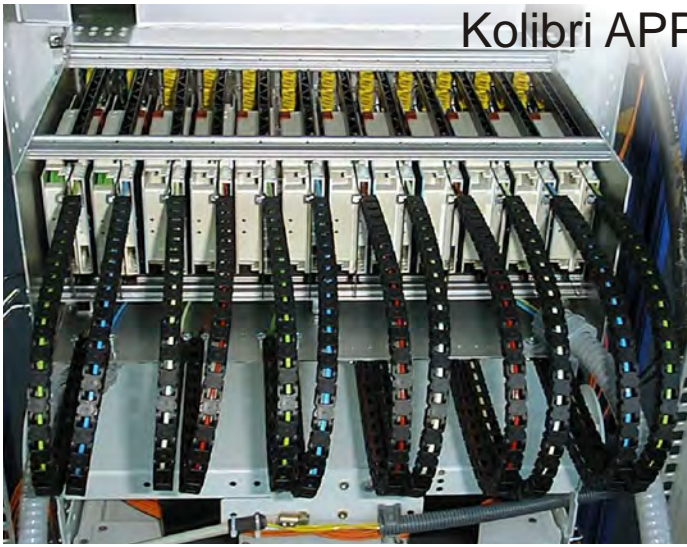

robotics, handling,
transportation, paper production,
textile industries, water plants



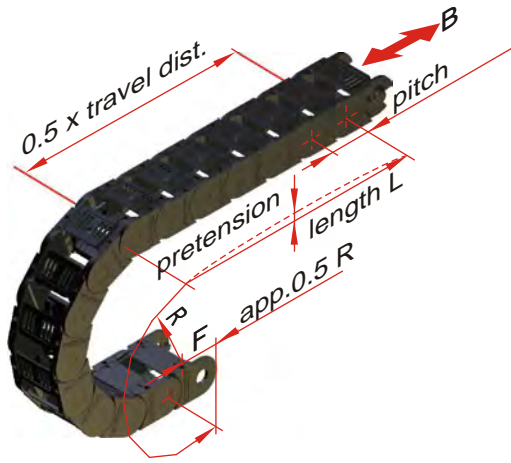
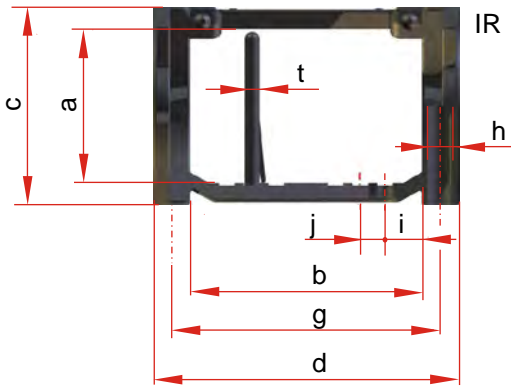

Kolibri c . d .type	prev. name		pitch	dimensions								weight kg/m	
				a	b	c	d	g	h	i ¹⁾	j ¹⁾		t ²⁾
10.012.4	00.3		15	Ø7	10	12	12	3	-	-	-	0.05	
13.023.4			20	9 14	13	23	19	3	-	-	-	0.12	
15.015.3	.4	0	0.3	20	Ø10	15	15	15	4	-	-	0.15	
15.036.5		02.5	18	10 25	15	36	30	4	-	-	-	0.30	
15.037.3			20	10 24	15	37	30	4	-	-	-	0.30	
15.051.0	03		20	10 39	15	51	44	4	-	-	-	0.35	
22.025.4	04.3		30	17 15	22	25	19,4	4	-	-	-	0.20	
22.038.0 .1	05.0		26	17 27	22	38	32.5	4	8	10	2	0.34	
22.048.0	06		30	17 36	22	48	41	4	13	10	2	0.37	
22.060.5		07.5	26	16 48	22	60	53	4	9,5	10	2	0.54	
30.030.3	1		40	24 18	30	30	23	4	-	-	-	0.50	
30.060.3	2		40	24 48	30	60	53	4	-	-	-	0.60	
30.050.0 .1	.5	10.0	10.5	35	23 34	30	50	40	5	9,5	5	3 ²⁾	0.54
30.060.0 .1	11.0		35	23 44	30	60	50	5	9,5	5	3	0.61	
30.080.0 .1 .2 .4 .5	12.0	12.5	35	23 64	30	80	70	5	9,5	5	3 ^{1),2)}	0.65	
30.095.0 .1	13.0		35	23 79	30	95	85	5	12	5	3	0.75	
30.125.0 .1	14.0		35	23 109	30	125	115	5	12	5	3	0.87	
40.062.2	.5	15.5	45	29 48	40	62	54	5	8	10	4	0.91	
40.075.2	.6		45	29 60	40	75	67	5	8	10	4	1.05	
50.065.0	.5	21.0	21.5	55	40 48	50	65	55	6	9 ³⁾	9 ³⁾	2	1.30
50.095.0 .1 .2 .5	19.0	19.5	55	40 78	50	95	85	6	6,5 ³⁾	5 ³⁾	2	1.35	
50.125.0 .1	22.0		55	40 108	50	125	115	6	6,5	5	3	1.52	
50.150.0 .1	.5	20.0	20.5	55	40 133	50	150	140	6	6,5 ³⁾	5 ³⁾	3	1.90
65.095.1	.5	24.5	70	50 77	65	95	85	6	13,5	10	4	2.20	
65.135.1	.5	25.5	70	50 117	65	135	125	6	13,5	10	4	2.60	
65.195.1		27.5	70	50 177	65	195	185	6	13,5	10	4	3,00	

1) not Kolibri *.2

2) for Kolibri *.2 is t=4 for Kolibri *.5 is t=2

3) for Kolibri *.5 is i=9,5 and j=10

Kolibri 00.000.0

standard type

flap open bars in inner radius
separable with pinch stay
integrated connector



Kolibri 00.000.1

openable in outer radius

flap open bars in outer radius
separable with pinch stay
integrated connector



Kolibri 00.000.2

rigid version

flap open bars in inner radius
separable with PZ
integrated connector



Kolibri 00.000.6
equal .2
flap open bars
in outer radius

Kolibri 00.000.3

one part chain links

not openable
not separable
integrated connector



Kolibri 00.000.4

film stay

film stay in inner radius
not separable
(integrated connector)



Kolibri 00.000.5

closed type

flap open covers in outer radius
separable with pinch stay
integrated connector



Kolibri

c . d . type	prev. name		radius									
			15	30	50	Kolibri 00.000.7 telescopic type PKK stays in inner radius separable via Pz separate connectors						
10.012.4	00.3		15	30	50							
13.023.4			17,5	35								
15.015.3	.4	0	0.3	17,5 ²⁾	20	30						
15.036.5		02.5		30	50							
15.037.3				24	30							
15.051.0	03			20	30							
22.025.4	04.3				35	70	100					
22.038.0 .1	05.0				35	50	60	70	100			
22.048.0	06				35	70						
22.060.5		07.5				50	70	100				
30.030.3	1					40	100	200				
30.060.3	2					40	100	150	200			
30.050.0 .1	.5	10.0	10.5		40 ¹⁾	60	75	100	150	200		
30.060.0 .1	11.0				40	50	75	100	150	200		
30.080.0 .1 .2 .4 .5	12.0	12.5			40 ¹⁾	60 ⁴⁾	75	100	150	200		
30.095.0 .1	13.0				40	75	100	125	150	200		
30.125.0 .1	14.0				40	75	100	150	200			
40.062 .2	.5	15.5				60 ¹⁾	75	100	150	200		
40.075.2	.6					60	75	100	150	200		
50.065.0	.5	21.0	21.5			75 ¹⁾	100	125 ¹⁾	150	200	250	
50.095.0 .1 .2 .5	19.0	19.5				75 ¹⁾	100	125 ¹⁾	150	175 ¹⁾	200	250
50.125.0 .1	22.0					75	100 ⁵⁾	125	150	200 ⁵⁾	250 ⁵⁾	
50.150.0 .1	.5	20.0	20.5			75 ¹⁾	100	150	200	250		
65.095.1	.5	24.1	24.5					125	150	200	300	
65.135.1	.5		25.5					125	150	200	300	400
65.195.1	.5		27.5					125	150	200	300	

1) not Kolibri xx.xxx.5

2) only Kolibri 15.015.3

4)only Kolibri 30.080.5

5) not 50.125.1

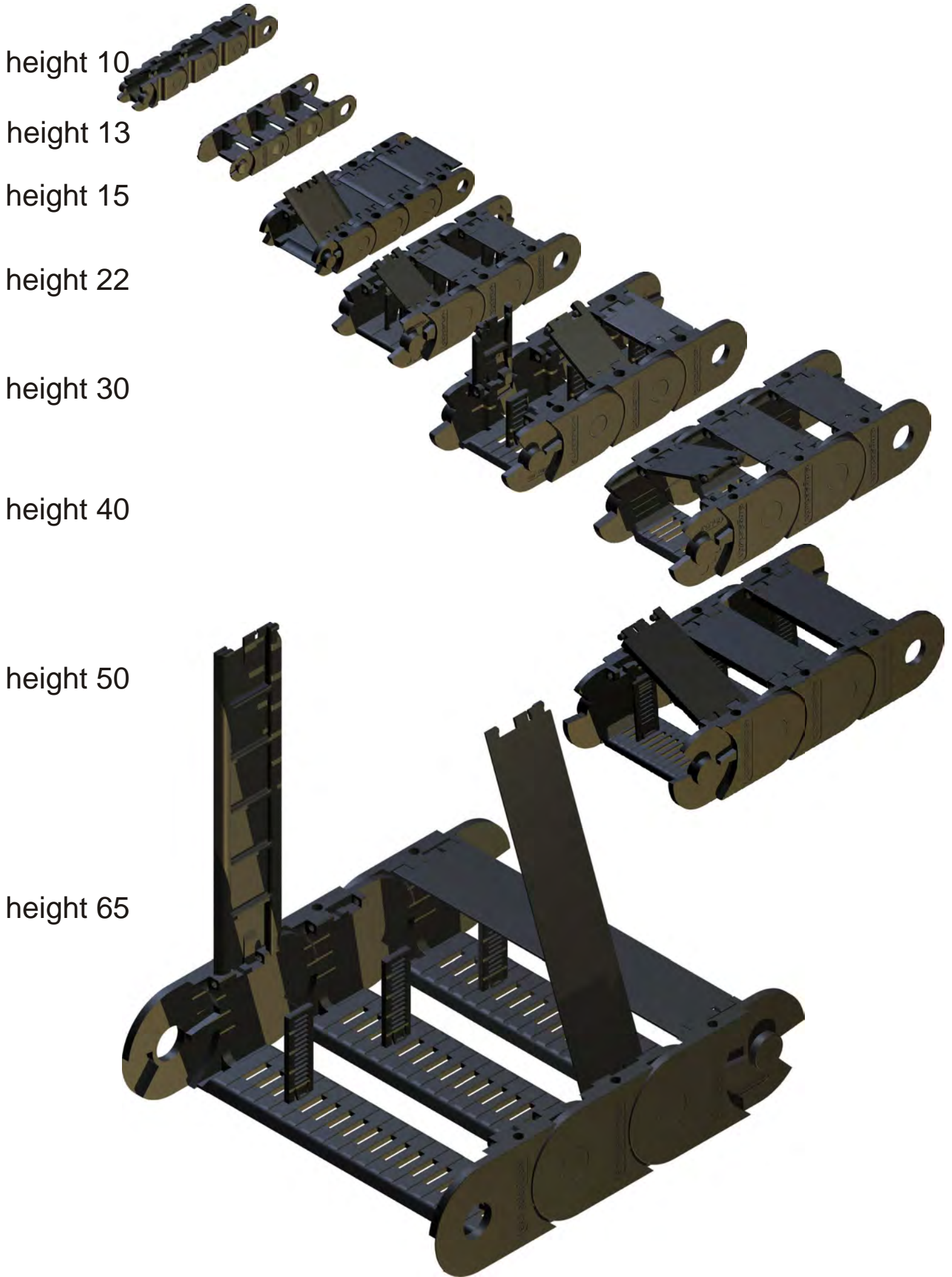

Kolibri HEIGHT 10

inner height 7 up to 8, inner width 7 up to 14

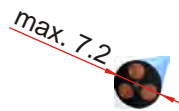

Kolibri 10.012.4

one part link
 film stay in inner radius
 integrated connector or separate connectors
space (axb): $\varnothing 7$ **not separable**
 bend radius: 15 / 30 / 50
 weight: 0,05 kg/m
 free carrying length: 0.4 m at 0.3 kg/m load
 pitch: 15

order example:

Kolibri 10.012.4 / 50 x 1005

type / radius x length

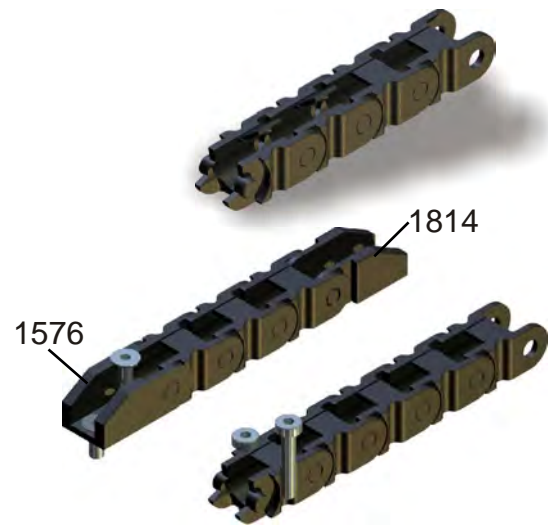

Kolibri 13.023.4

one part link
 fether stay in inner radius
 integrated connector
space (axb): **8x14** **not separable**
 bend radius: 17,5 / 35 / 55 / 80 / 100
 weight: 0,12 kg/m
 free carrying length: 0,8 m at 0.5 kg/m load
 pitch: 20

order example:

Kolibri 10.012.4 / 50 x 1005

type / radius x length

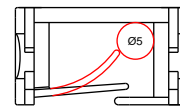

fether stay long
 max. $\varnothing 5$ mm

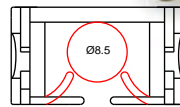

fether stay short
 Max. $\varnothing 8.5$ mm



Snap

(see page 26,32,39,41)



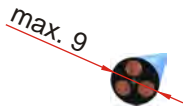

Kolibri HEIGHT 15

inner height 10, inner width 10 to 39

Kolibri 15.015.3

one part chain link
 not openable
 connector as separate part (part.no. 0700)
space (axb): Ø10 not separable
 bend radius: 17.5 / 20 / 30
 weight: 0.15 kg/m
 free carrying length: 0,9.m at 0.9 kg/m load
 pitch: 20

order example:

Kolibri 15.015.3 / 30 x 1000

type / radius x length



Kolibri 15.015.4

one part chain link
 film-stay in inner radius
 connector as separate part (see Kolibri 15.015.3)
space (axb): Ø10 not separable
 bend radius: 20 / 30
 weight: 0.15 kg/m
 free carrying length: 0.9 m at 0.9 kg/m load
 pitch: 20

order example:

Kolibri 15.015.4 / 30 x 1000

type / radius x length

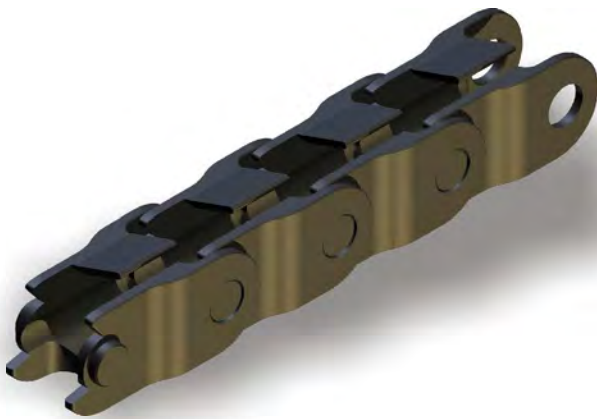

Kolibri 15.036.5

closed type
 flap covers in outer radius
 integrated connectors
space (axb): 10 x 25 not separable
 bend radius: 30 / 50
 weight: 0.3 kg/m
 free carrying length: 0.9m at 0.9 kg/m load
 pitch: 18

order example:

Kolibri 15.036.5 / 30 x 1008

type / radius x length

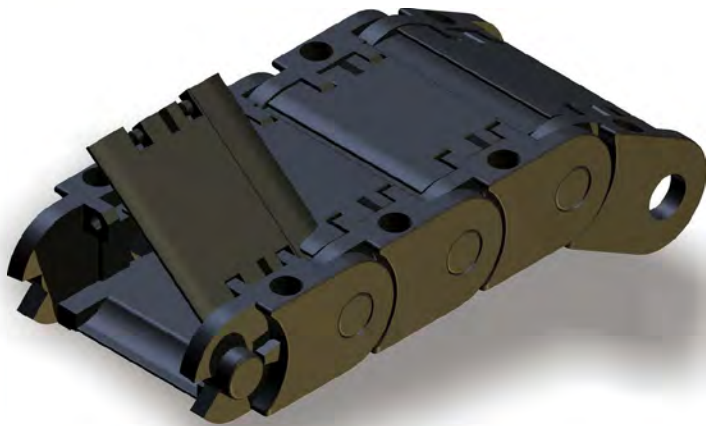

Kolibri HEIGHT 15

inner height 10, inner width 10 to 39

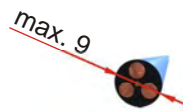

Kolibri 15.037.3

one part chain link
not openable, closed in outer radius
integrated connectors

Space (axb): 10 x 24 not separable
bend radius: 24, 30
weight: 0.3 kg/m
free carrying length: 0.9 at 0.9 kg/m load
pitch: 20

order example:

Kolibri 15.037.3 / 30 x 1000

type / radius x length



Kolibri 15.051.0

standard type
flap stay in inner radius
integrated connectors

space (axb): 10 x 39 not separable
bend radius: 20 / 30
weight: 0.35 kg/m
free carrying length: 0.9 m at 0.9 kg/m load
pitch: 20

order example:

Kolibri 15.051.0 / 30 x 1000

type / radius x length

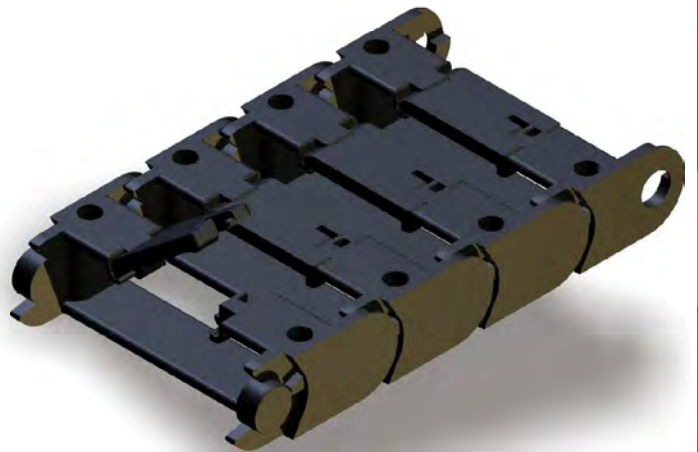

Kolibri HEIGHT 22

inner height 16 to 22, inner width 15 to 48

Kolibri 22.025.4

one part chain link
film stay
integrated connectors

space (axb): **17 x 15 not separable**
 bend radius: 35 / 70 / 100
 weight: 0.20 kg/m
 free carrying length: 1.3 m at 1.5 kg/m load
 pitch: 30

order example:

Kolibri 22.025.4 / 35 x 1020

type / radius x length



Kolibri 22.038.0

standard type
flap stay in inner radius
integrated connectors

space (axb): **17 x 27 separable (PZ ANr.1688)**
 bend radius: 35 / 50 / 70 / 100
 weight: 0.34 kg/m
 free carrying length: 1.5 m at 1.0 kg/m load
 pitch: 26

order example:

Kolibri 22.038.0 / 35 x 1040

type / radius x length

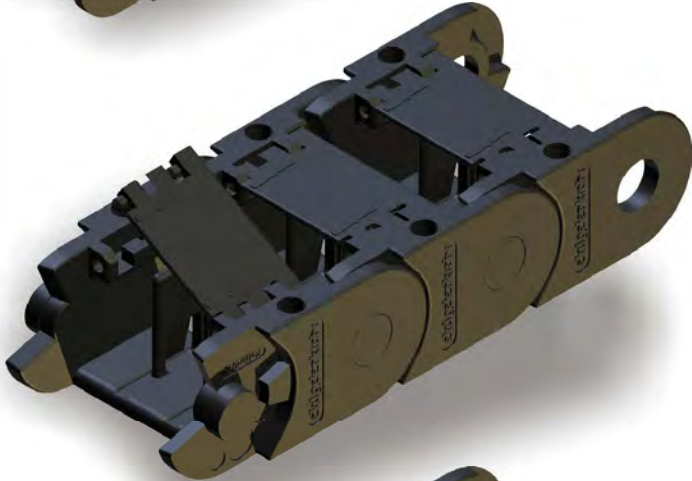

Snap

Assembly example:

Kolibri 22.038.0 is available with Snap connectotr:

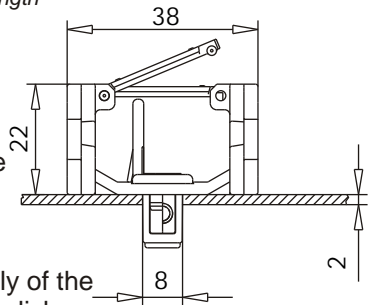

Quick and toolless assembly of the energy chain with only one click.

Please contact the ekd gelenkrohr design department.

Kolibri 22.038.1

open type
flap stay in outer radius
integrated connectors

space (axb): **17 x 27 separable (PZ ANr.1688)**
 bend radius: 35
 weight: 0.34 kg/m
 free carrying length: 1.5 m at 1.0 kg/m load
 pitch: 26

order example:

Kolibri 22.038.1 / 35 x 1040

type / radius x length

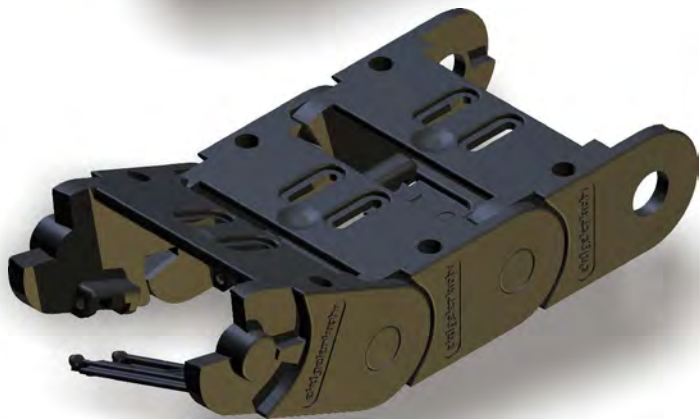

Kolibri HEIGHT 22

inner height 16 to 22, inner width 15 to 48

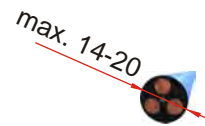

Kolibri 22.048.0

open type
flap stay in inner radius
integrated connectors

space (axb): 17 x 36 not separable
bend radius: 35 / 70
weight: 0.37 kg/m
free carrying length: 1.3 m at 1.5 kg/m load
pitch: 30

order example:

Kolibri 22.048.0 / 35 x 1200

type / radius x length

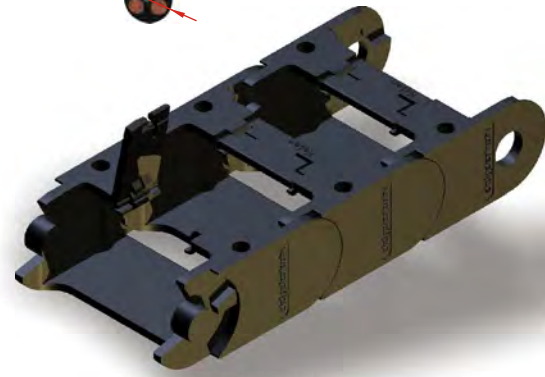

Kolibri 22.060.5

closed type
flap stay in outer radius
integrated connectors

space (axb): 16 x 48 separable (PZ ANr.1294)
bend radius: 50 / 70 / 100
weight: 0.54 kg/m
free carrying length: 1.3 m at 1.5 kg/m load
pitch: 26

order example:

Kolibri 22.060.5 / 100 x 1014

type / radius x length



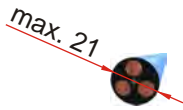

Kolibri HEIGHT 30

inner height 23 to 24, inner width 18 to 109

Kolibri 30.030.3

one part chain link
not openable
integrated connectors

space (axb): **24 x 18 not separable**
bend radius: 40 / 100 / 200
weight: 0.50 kg/m
free carrying length: 1.5 m at 2.0 kg/m load
pitch: 40

order example:

Kolibri 30.030.0 / 100 x 1200

type / radius x length

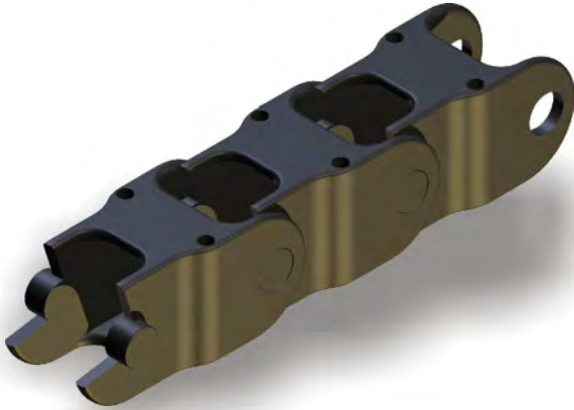

Kolibri 30.050.0

standard type
flap stay in inner radius
integrated connectors

space (axb): **23 x 34 separable (PZ ANr.1258)**
bend radius: 40 / 60 / 75 / 100 / 150 / 200
weight: 0.54 kg/m
free carrying length: 1.5 m at 2.0 kg/m load
pitch: 35

order example:

Kolibri 30.050.0 / 100 x 1225

type / radius x length

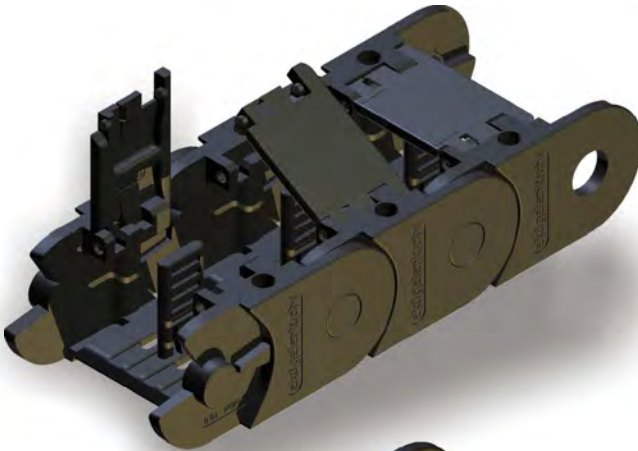

Kolibri 30.050.1

open type
flap stay in outer radius
integrated connectors

space (axb): **23 x 34 separable (PZ ANr.1258)**
bend radius: 40 / 60 / 75 / 100 / 150 / 200
weight: 0.54 kg/m
free carrying length: 1.5 m at 2.0 kg/m load
pitch: 35

order example:

Kolibri 30.050.1 / 100 x 1225

type / radius x length

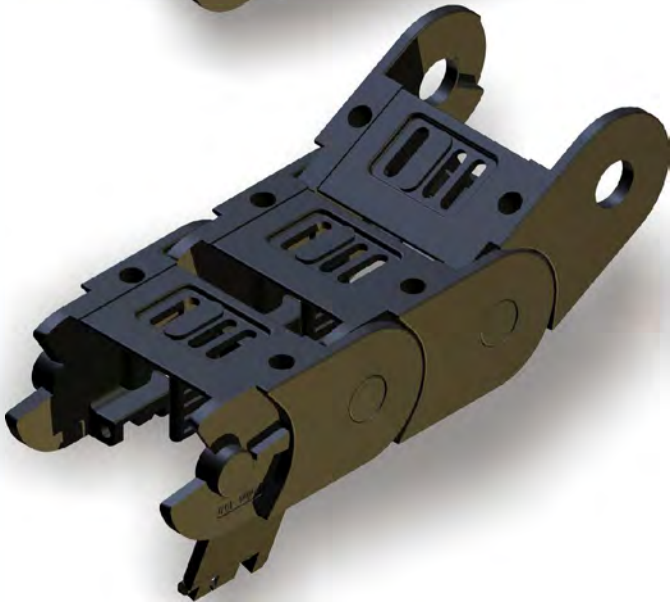

Kolibri 30.050.5

closed type
flap covers in outer radius
integrated connectors

space (axb): **23 x 34 separable (PZ ANr.1017)**
bend radius: 60 / 75 / 100 / 150 / 200
weight: 0.58 kg/m
free carrying length: 1.5 m at 2.0 kg/m load
pitch: 35

order example:

Kolibri 30.050.5 / 100 x 1225

type / radius x length

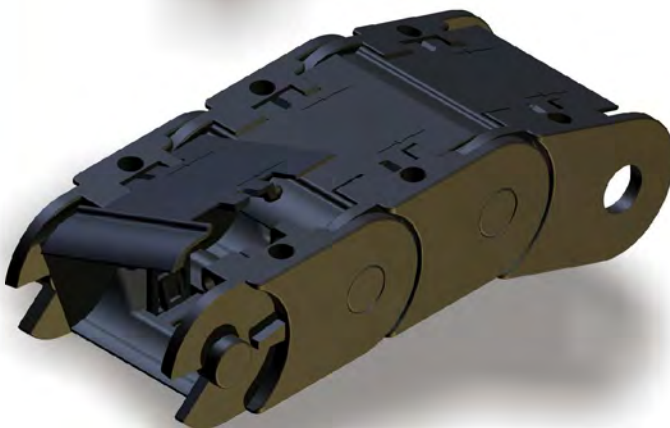

Kolibri HEIGHT 30

inner height 23 to 24, inner width 18 to 109



Kolibri 30.060.0

standard type
flap stay in inner radius
integrated connectors

space (axb): 23 x 44 separable (PZ ANr.1258)
bend radius: 40 / 50 / 75 / 100 / 150 / 200
weight: 0.61 kg/m
free carrying length: 1.5 m at 2.0 kg/m load
pitch: 35

order example:

Kolibri 30.060.0 / 100 x 1225

type / radius x length

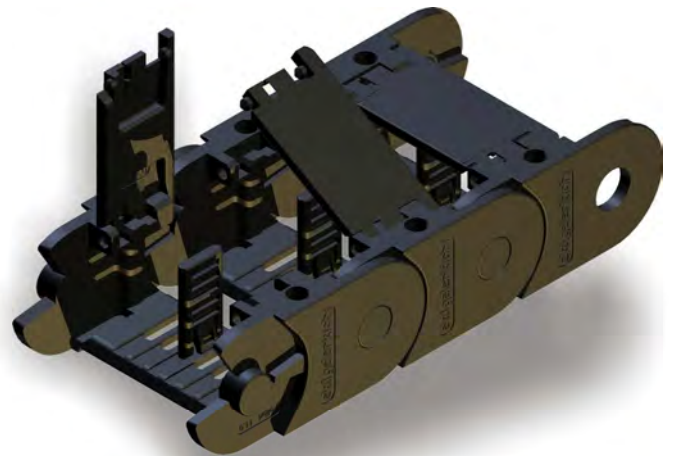

Kolibri 30.060.1

open type
flap stay in outer radius
integrated connectors

space (axb): 23 x 44 separable (PZ ANr.1258)
bend radius: 40 / 50 / 75 / 100 / 150 / 200
weight: 0.61 kg/m
free carrying length: 1.5 m at 2.0 kg/m load
pitch: 35

order example:

Kolibri 30.060.1 / 100 x 1225

type / radius x length

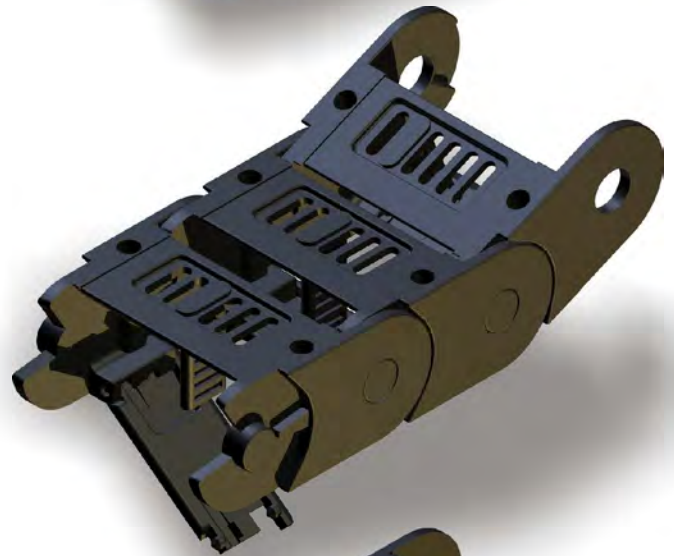

Kolibri 30.060.3

open type
not openable
integrated connectors

space (axb): 24 x 48
bend radius: 40 / 100 / 150 / 200
weight: 0.60 kg/m
free carrying length: 1.5 m at 2.0 kg/m load
pitch: 40

order example:

Kolibri 30.060.3 / 100 x 1200

type / radius x length

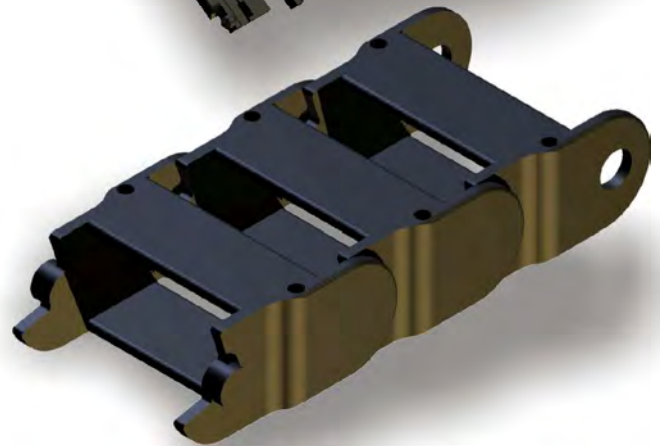

Kolibri 30.080.0

standard type
flap stay in inner radius
integrated connectors

space (axb): 23 x 64 separable (PZ ANr.1258)
bend radius: 40 / 75 / 100 / 150 / 200
weight: 0.65 kg/m
free carrying length: 1.5 m at 2.0 kg/m load
pitch: 35

order example:

Kolibri 30.080.0 / 100 x 1225

type / radius x length

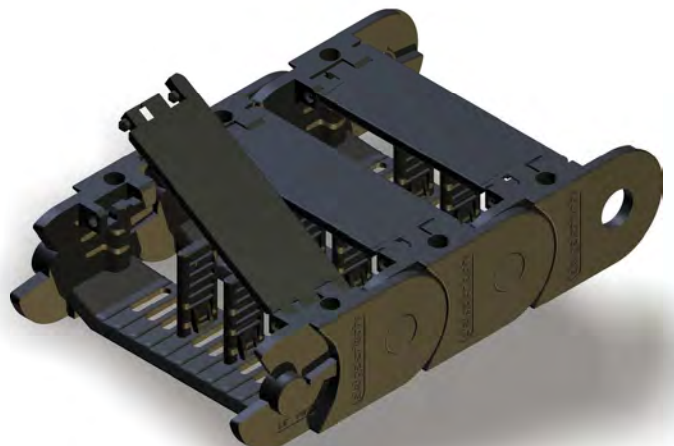



Kolibri HEIGHT 30

inner height 23 to 24, inner width 18 to 109

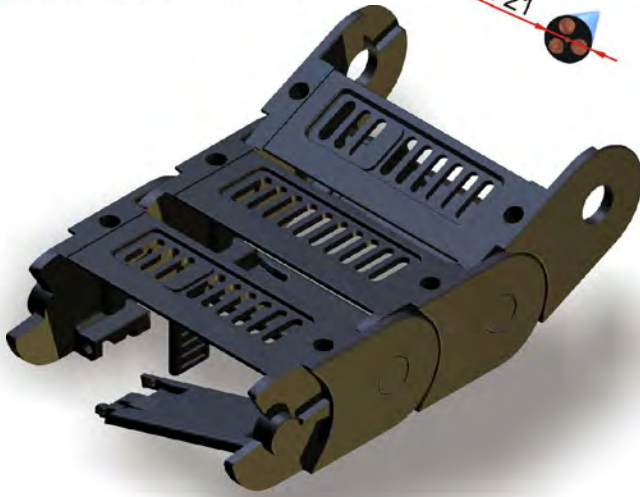

Kolibri 30.080.1

standard type
flap stay in outer radius
integrated connectors

space (axb): **23 x 64 separable (PZ ANr.1258)**
 bend radius: 40 / 75 / 100 / 150 / 200
 weight: 0.65 kg/m
 free carrying length: 1.5 m at 2.0 kg/m load
 pitch: 35

order example:

Kolibri 30.080.0 / 100 x 1225

type / radius x length

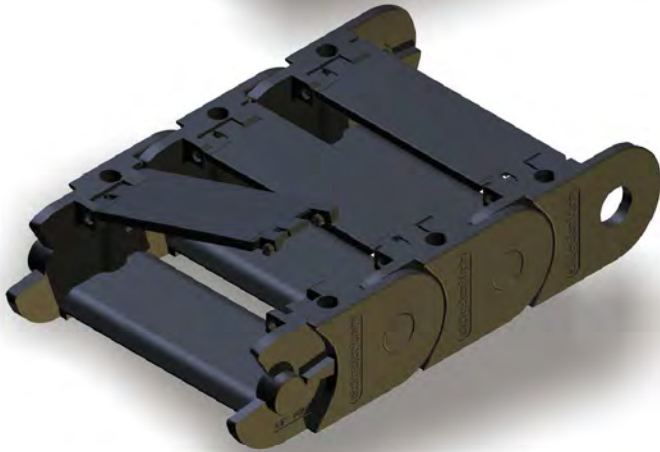

Kolibri 30.080.2

rigid type
flap stay in inner radius
integrated connectors

space (axb): **21 x 64 not separable**
 bend radius: 40 / 75 / 100 / 150 / 200
 weight: 0.7 kg/m
 free carrying length: 1.5 m at 2.0 kg/m load
 pitch: 35

order example:

Kolibri 30.080.2 / 100 x 1225

type / radius x length

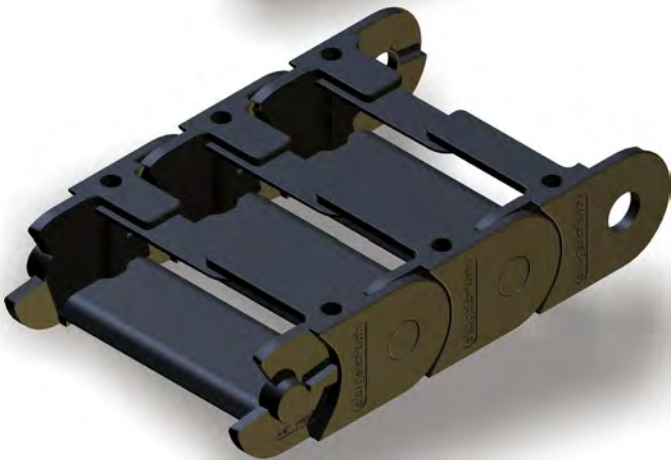

Kolibri 30.080.4

one part chain link
lining without assembly
integrated connectors

space (axb): **21 x 64 not separable**
 bend radius: 40 / 75 / 100 / 150 / 200
 weight: 0.65 kg/m
 free carrying length: 1.5 m at 2.0 kg/m load
 pitch: 35

order example:

Kolibri 30.080.4 / 100 x 1225

type / radius x length

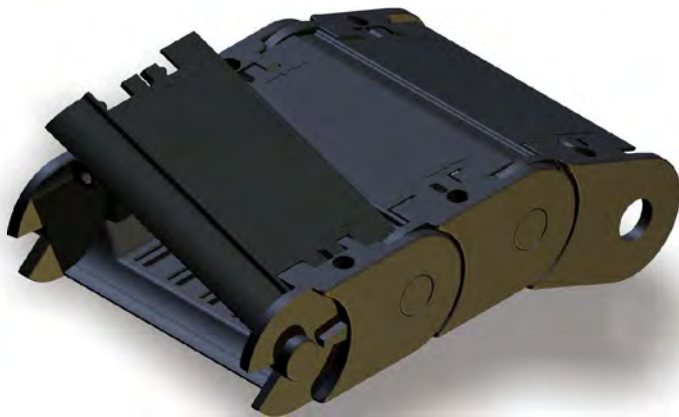

Kolibri 30.080.5

closed type
flap covers in outer radius
integrated connectors

space (axb): **23 x 64 separable (PZ ANr.1017)**
 bend radius: 60 / 75 / 100 / 150 / 200
 weight: 0.7 kg/m
 free carrying length: 1.5 m at 2.0 kg/m load
 pitch: 35

order example:

Kolibri 30.080.5 / 100 x 1225

type / radius x length

Kolibri HEIGHT 30

inner height 23 to 24, inner width 18 to 109

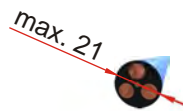

Kolibri 30.095.0

standard type
flap stays in inner radius
integrated connectors

space (axb): 23 x 79 separable (PZ ANr.1258)
bend radius: 40 / 75 / 100 / 125 / 150 / 200
weight: 0.75 kg/m
free carrying length: 1.5 m at 2.0 kg/m load
pitch: 35

order example:

Kolibri 30.095.0 / 100 x 1225

type / radius x length

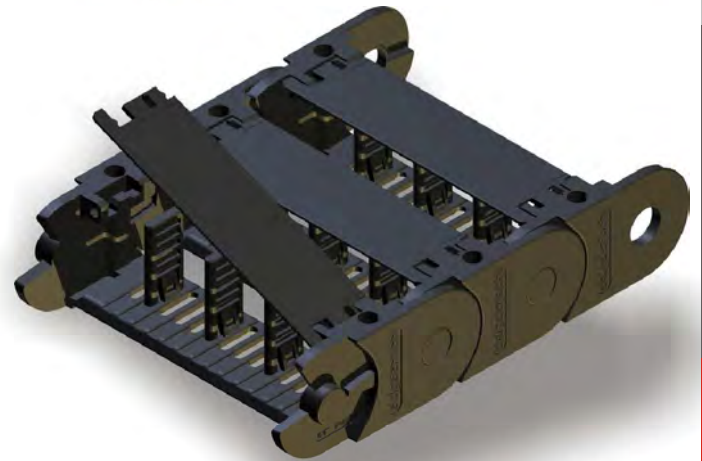

Kolibri 30.095.1

open type
flap stays in outer radius
integrated connectors

space (axb): 23 x 79 separable (PZ ANr.1258)
bend radius: 40 / 75 / 100 / 125 / 150 / 200
weight: 0.75 kg/m
free carrying length: 1.5 m at 2.0 kg/m load
pitch: 35

order example:

Kolibri 30.095.1 / 100 x 1225

type / radius x length

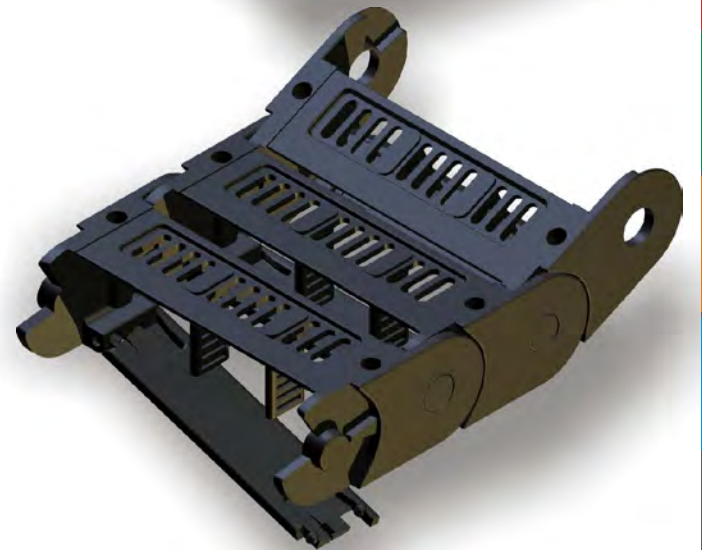

Snap

toolless assembly
of the chain





Kolibri HEIGHT 30

inner height 23 to 24, inner width 18 to 109

Kolibri 30.125.0

standard type
flap stay in inner radius
integrated connectors

space (axb): **23 x 109 separable (PZ ANr.1258)**
 bend radius: 40 / 75 / 100 / 150 / 200
 weight: 0.87 kg/m
 free carrying: 1.5 m at 2.0 kg/m load
 pitch: 35

order example:

Kolibri 30.125.0 / 100 x 1225

type / radius x length

Kolibri 30.125.1

open type
flap stay in outer radius
integrated connectors

space (axb): **23 x 109 separable (PZ ANr.1258)**
 bend radius: 40 / 75 / 100 / 150 / 200
 weight: 0.87 kg/m
 free carrying: 1.5 m at 2.0 kg/m load
 pitch: 35

order example:

Kolibri 30.125.1 / 100 x 1225

type / radius x length

Kolibri with Snap

Type Kolibri allows using the Snap connector:
Fast and toolless assembly of the energy chain with only one click.
Please contact ekd gelenkrohr technic during your Planing phase.

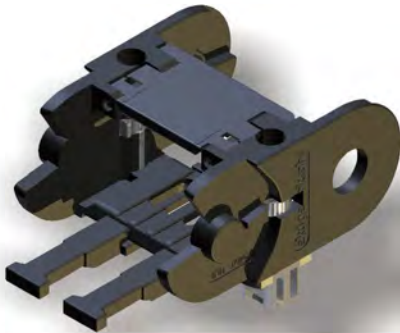
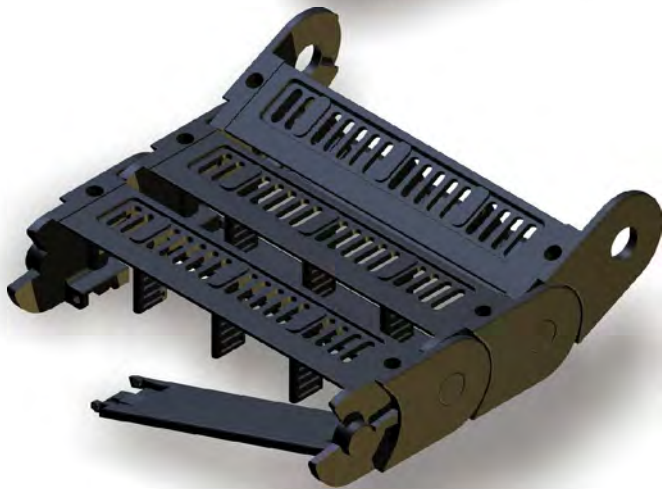
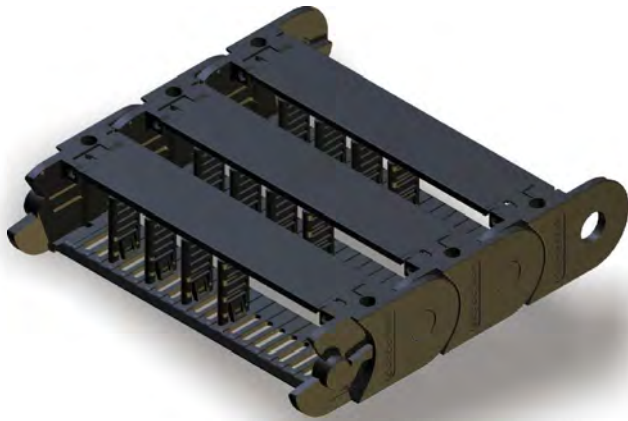

assembly example:

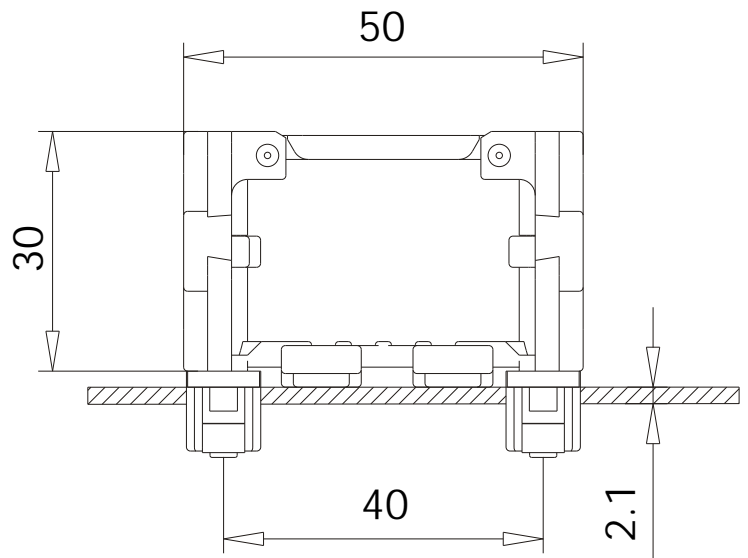
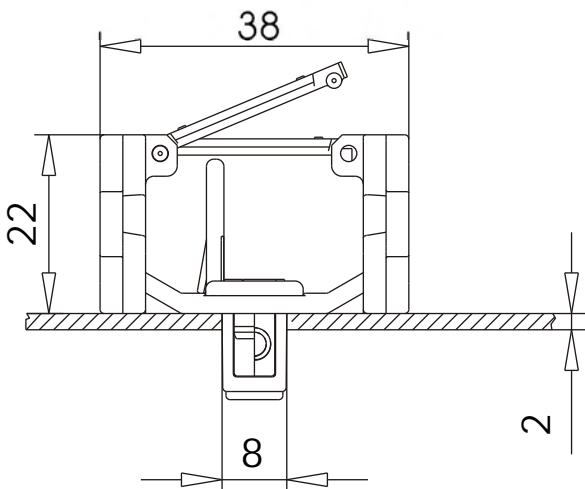

Kolibri HEIGHT 40

inner height 31, inner width 48 to 60

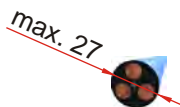

Kolibri 40.062.2

rigid type
flap stay in inner radius
integrated connectors

space (axb): 29 x 48 separable (PZ ANr.1521)
bend radius: 60 / 75 / 100 / 150 / 200
weight: 0.91 kg/m
free carrying length: 2.0 m at 1.0 kg/m load
pitch: 45

order example:

Kolibri 40.062.2 / 100 x 1260

type / radius x length

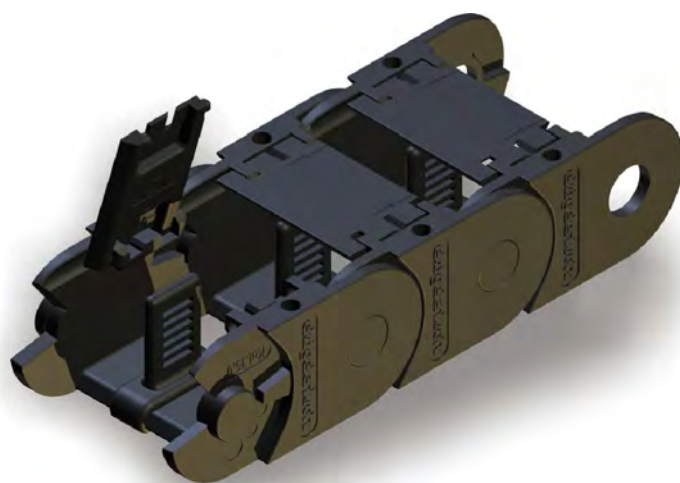

Kolibri 40.062.5

closed type
flap covers in outer radius
integrated connectors

space (axb): 29 x 48 separable (PZ ANr.1268)
bend radius: 75 / 100 / 150 / 200
weight: 0.93 kg/m
free carrying length: 2.0 m at 1.0 kg/m load
pitch: 45

order example:

Kolibri 40.062.5 / 100 x 1260

type / radius x length

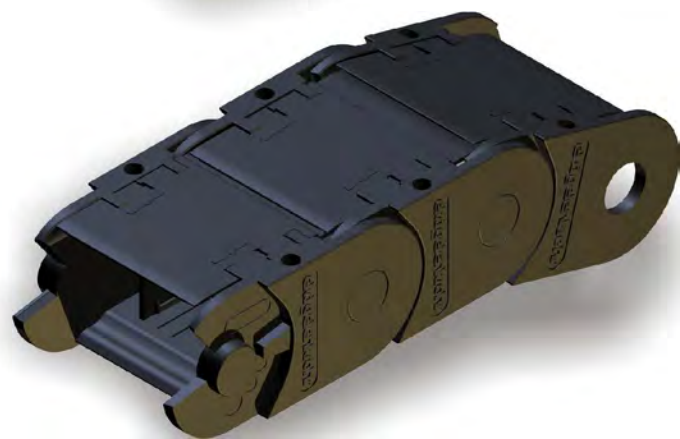

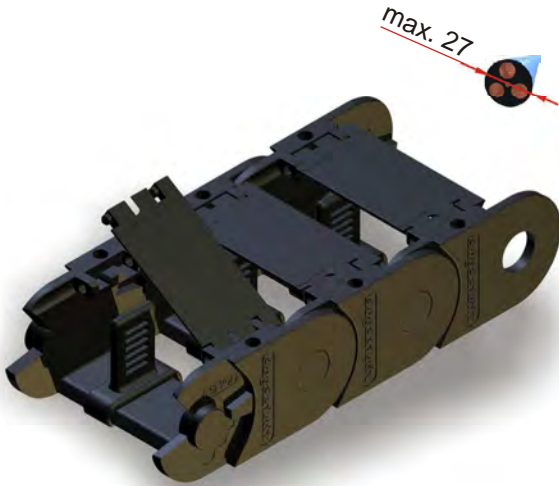

Kolibri HEIGHT 40

inner height 31, inner width 48 to 60

Kolibri 40.075.2

- rigid type
- flap stay in inner radius
- integrated connectors
- space (axb): **29 x 60** separable (PZ ANr.1521)
- bend radius: 60 / 75 / 100 / 150 / 200
- weight: 1.05 kg/m
- free carrying length: 2.0 m at 1.0 kg/m load
- pitch: 45

order example:

Kolibri 40.075.2 / 100 x 1260

type / radius x length

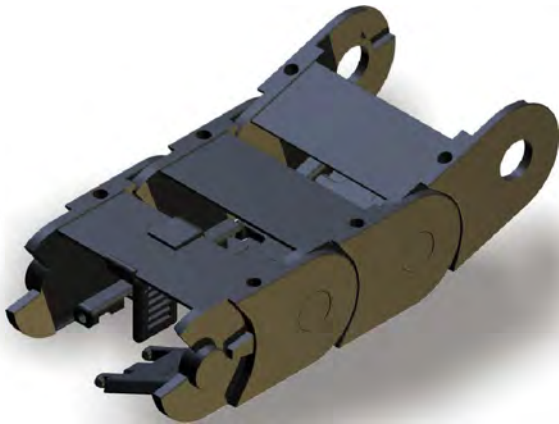

Kolibri 40.075.6

- rigid type
- flap stay in outer radius
- integrated connectors
- space (axb): **29 x 60** separable (PZ ANr.1521)
- bend radius: 60 / 75 / 100 / 150 / 200
- weight: 1.05 kg/m
- free carrying length: 2.0 m at 1.0 kg/m load
- pitch: 45

order example:

Kolibri 40.075.6 / 100 x 1260

type / radius x length



stay length 50 up to 100

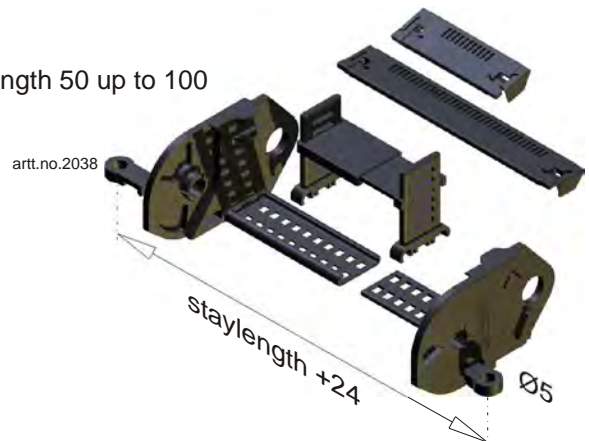

Kolibri HEIGHT 50

inner height 38 to 40, inner width 48 to 134



Kolibri 50.065.0

standard type
flap stay in inner radius
integrated connectors

space (axb): 40 x 48 separable (PZ ANr.1113)
bend radius: 75 / 100 / 125 / 150 / 200 / 250
weight: 1.30 kg/m
free carrying: 2.4 m at 1.0 kg/m load
pitch: 55

order example:

Kolibri 50.065.0 / 100 x 1265

type / radius x length

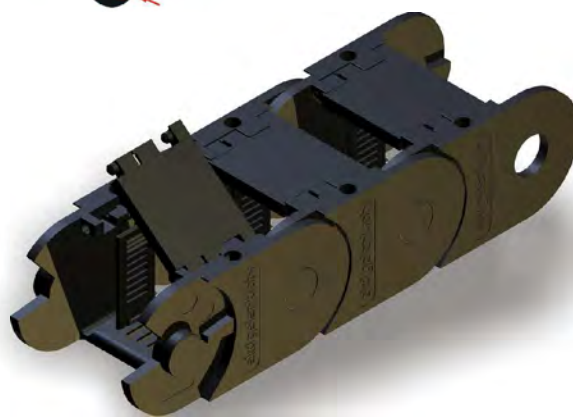

Kolibri 50.065.5

colsed type
flap covers in outer radius
integrated connectors

space (axb): 40 x 48 separable (PZ ANr.1113)
bend radius: 100 / 150 / 200 / 250
weight: 1.30 kg/m
free carrying length: 2.4 m at 1.0 kg/m load
pitch: 55

order example:

Kolibri 50.065.5 / 100 x 1265

type / radius x length

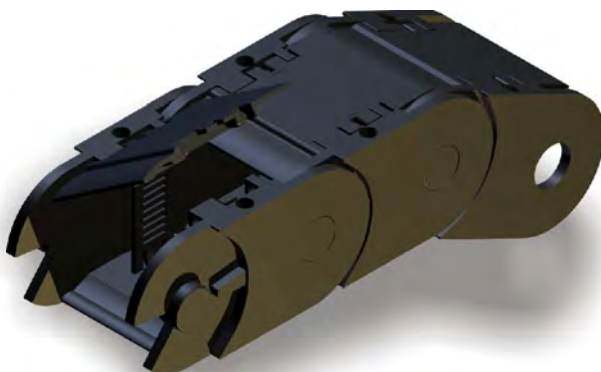

Kolibri 50.095.0 50.095.1

standard type
flap stay in inner radius flap stay in outer radius
integrated connectors

space (axb): 40 x 78 separable (PZ ANr.1113)
bend radius: 75/100/ 125/ 150/ 175/ 200/ 250
weight: 1.35 kg/m
free carrying length: 2.4 m at 1.0 kg/m load
pitch: 55

order example:

Kolibri 50.095.0 / 100 x 1265

type / radius x length

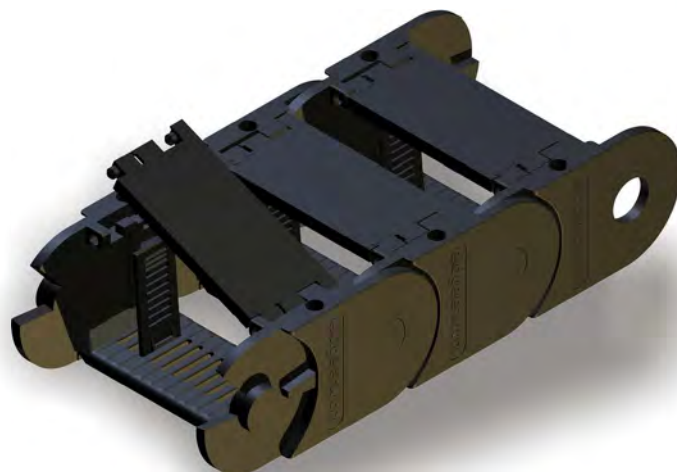

Kolibri 50.095.2

rigid type
flap stay in inner radius
integrated connectors

space (axb): 38 x 78 separable (PZ ANr.1451)
bend radius: 75/100/ 125/ 150/ 175/ 200/ 250
weight: 1.40 kg/m
free carrying length: 2.4 m at 1.0 kg/m load
pitch: 55

order example:

Kolibri 50.095.2 / 100 x 1265

type / radius x length

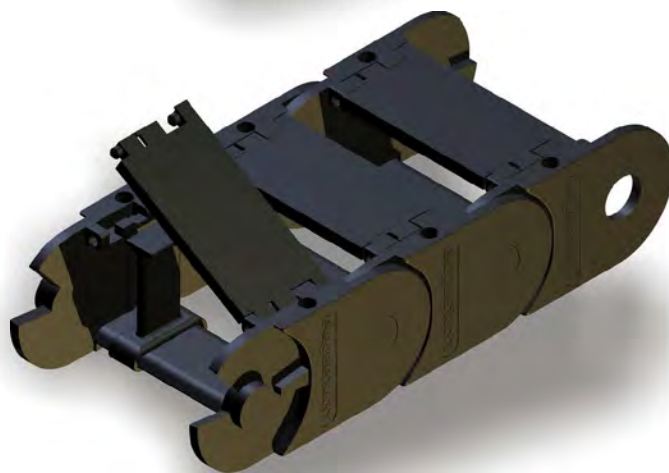



Kolibri HEIGHT 50

inner height 38 to 40, inner width 48 to 134

Kolibri 50.095.5

closed type
flap stay in outer radius
integrated connectors

space (axb): 40 x 78 separable (PZ ANr.1113)
bend radius: 100/ 125/ 150/ 175/ 200/ 250
weight: 1.40 kg/m
free carrying length: 2.4 m at 1.0 kg/m load
pitch: 55

order example:

Kolibri 50.095.5 / 100 x 1265

type / radius x length

Kolibri 50.125.0 50.125.1

standard type
flap stay in inner radius
Integrated connectors

space (axb): 40 x 108 separable (PZ ANr.1326)
bend radius: 75 / 100 / 125 / 150 / 200 / 250
weight: 1.52 kg/m
free carrying length: 2.4 m at 1.0 kg/m load
pitch: 55

order example:

Kolibri 50.125.0 / 100 x 1265

type / radius x length

Kolibri 50.150.0 50.150.1

standard type
flap stay in inner radius
integrated connectors

space (axb): 40 x 133 separable (PZ ANr.1326)
bend radius: 75 / 100 / 150 / 200 / 250
weight: 1.90 kg/m
free carrying length: 2.4 m at 1.0 kg/m load
pitch: 55

order example:

Kolibri 50.150.0 / 100 x 1265

type / radius x length

Kolibri 50.150.5

closed type
flap stay in outer radius
integrated connectors

space (axb): 40 x 133 separable (PZ ANr.1113)
bend radius: 75 / 100 / 150 / 200 / 250
weight: 1.90 kg/m
free carrying length: 2.4 m at 1.0 kg/m load
pitch: 55

order example:

Kolibri 50.150.5 / 100 x 1265

type / radius x length

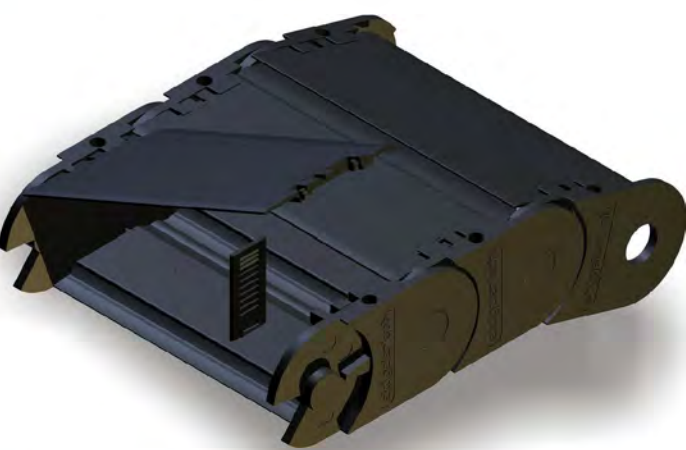
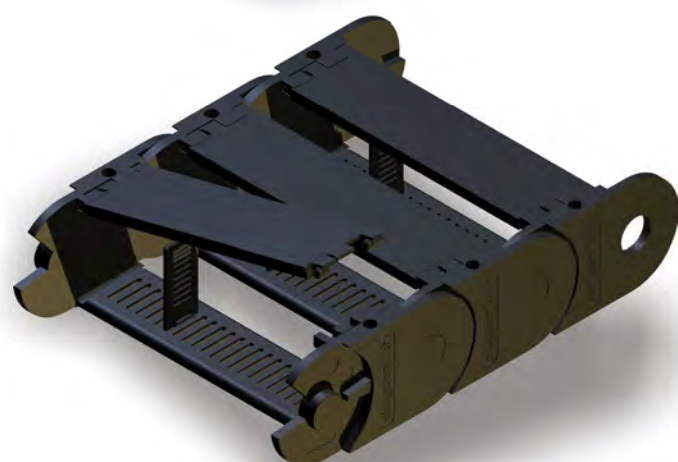
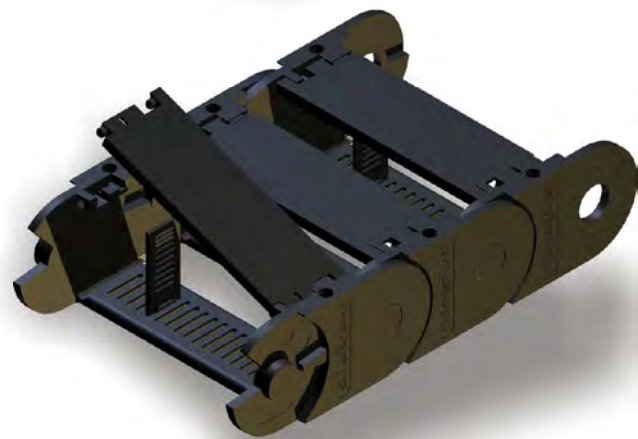
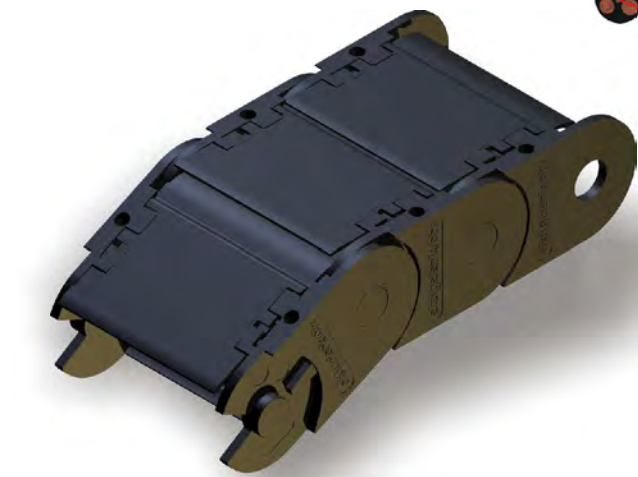

Kolibri HEIGHT 65

inner height 50, inner width 77 to 205

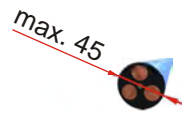

Kolibri 65.095.1

open type
flap stay in outer radius
integrated connectors

space (axb): 50 x 77 separable (PZ ANr.1129)
bend radius: 125 / 150 / 200 / 300
weight: 2.2 kg/m
free carrying length: 2.75 m at 1.0 kg/m load
pitch: 70

order example:

Kolibri 65.095.1 / 125 x 1400

type / radius x length

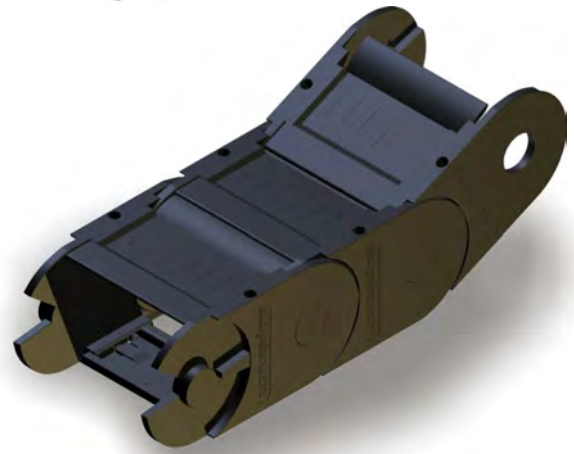

Kolibri 65.095.5

closed type
flap cover in outer radius
integrated connectors

space (axb): 50 x 77 separable (PZ ANr.1129)
bend radius: 125 / 150 / 200 / 300
weight: 2.2 kg/m
free carrying length: 2.75 m at 1.0 kg/m load
pitch: 70

order example:

Kolibri 65.095.5 / 125 x 1400

type / radius x length

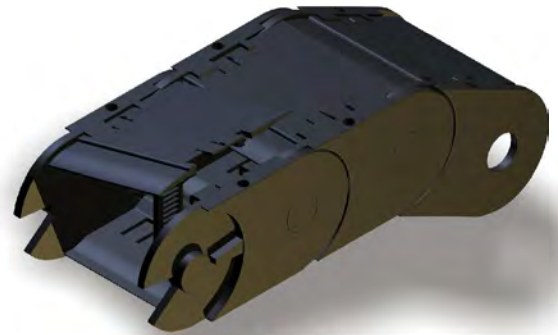

Kolibri 65.135.1

open type
flap stay in outer radius
integrated connectors

space (axb): 50 x 117 separable (PZ ANr.1129)
bend radius: 125 / 150 / 200 / 300 / 400
weight: 2.6 kg/m
free carrying length: 2.75 m at 1.0 kg/m load
pitch: 70

order example:

Kolibri 65.135.1 / 125 x 1400

type / radius x length

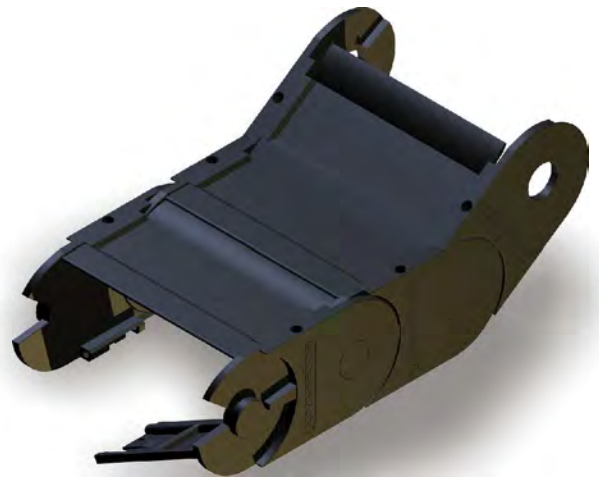

Kolibri 65.135.5

closed type
flap cover in outer radius
integrated connectors

space (axb): 50 x 117 separable (PZ ANr.1129)
bend radius: 125 / 150 / 200 / 300 / 400
weight: 2.7 kg/m
free carrying length: 2.75 m at 1.0 kg/m load
pitch: 70

order example:

Kolibri 65.135.1 / 125 x 1400

type / radius x length



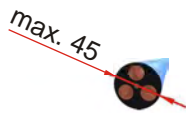

Kolibri HEIGHT 65

inner height 50, inner width 77 to 205

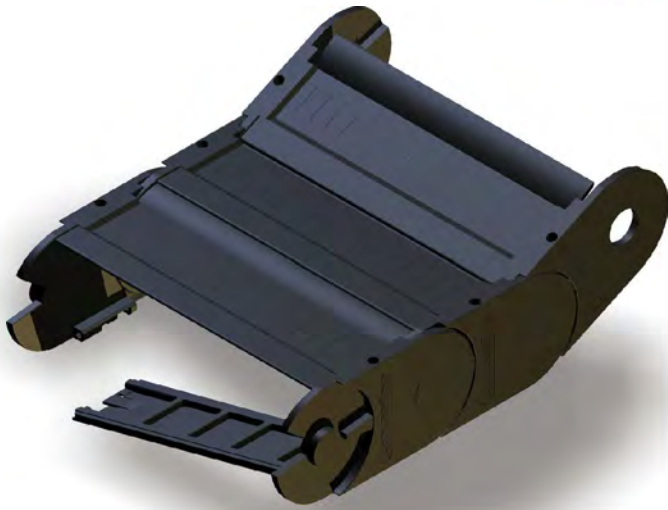

Kolibri 65.195.1

- open type
- flap stay in outer radius
- integrated connectors
- space (axb): **50 x 177 separable (PZ ANr.1129)**
- bend radius: 125 / 150 / 200 / 300
- weight: 2.9 kg/m
- free carrying length: 2.75 m at 1.0 kg/m load
- pitch: 70

order example:

Kolibri 65.195.1 / 125 x 1400

type / radius x length

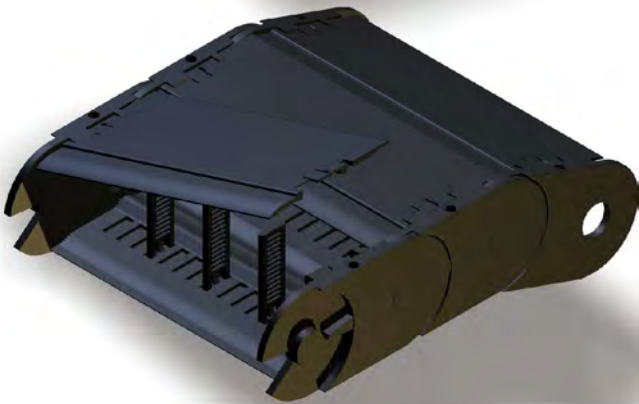

Kolibri 65.195.5

- closed type
- flap cover in outer radius
- integrated connectors
- space (axb): **50 x 177 separable (PZ ANr.1129)**
- bend radius: 125 / 150 / 200 / 300
- weight: 3.0 kg/m
- free carrying length: 2.75 m at 1.0 kg/m load
- pitch: 70

order example:

Kolibri 65.195.5 / 125 x 1400

type / radius x length

- | Pos. | name |
|------|----------------------------------|
| 1 | link (open type) |
| 2 | link (closed type) |
| 3 | flange pivot |
| 4 | flange drilling |
| 5 | horn stay connector |
| 6 | horn stay 65 HS65 |
| 7 | horn stay 85 HS 85 |
| 8 | damping element |
| 9 | PZ (divider) |
| 10 | PZ (pinch stay) |
| 11 | flap stay |
| 12 | flap cover |
| 13 | notched horizontal divider |
| 14 | notched horiz. divider flying |
| 15 | telescopic horizontal divider |
| 16 | telescopic horiz. divider flying |
| 17 | ladderstay |
| 20 | connector 10.012.4 hole |
| 21 | connector 10.012.4 pivot |

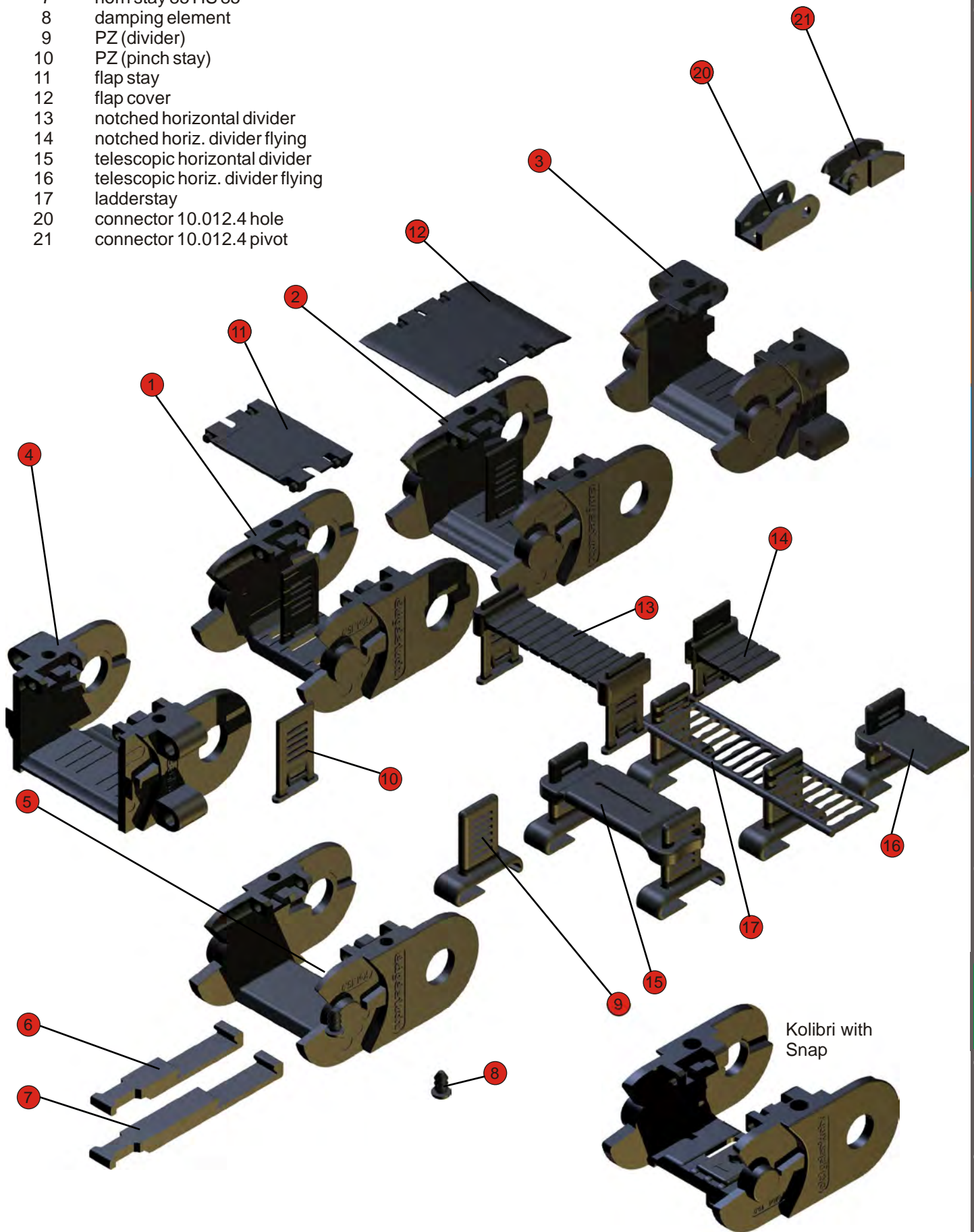

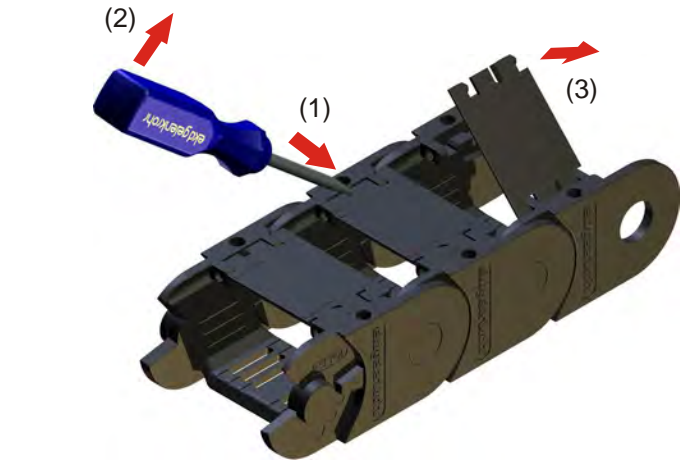

Opening and closing

Push a screwdriver as shown in the the slot (1) then with a light lever movement (2) raise the tongue and push the locking pins of the flap stay (or the flap cover) out of the drilling. The flap stay can then be lifted (3). To remove the flap stay the second side has to be unlocked and the stay has to be pushed out against the direction of the cones.

The installation of the flap stays and flap covers are snapped in a slight angle with the pins against the corresponding drillings (4) and with slight pressure against the locking tongue.

Lifted flap stays can be re-engaged (5) with slight pressure.

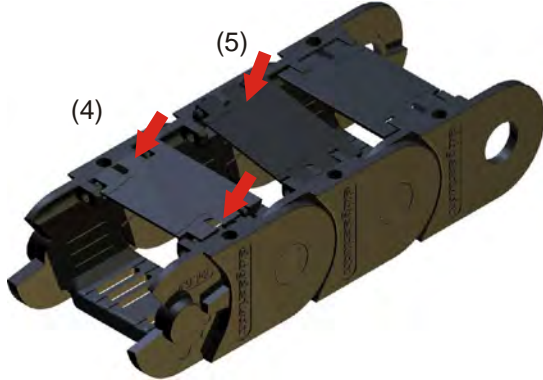

Lengthening and shortening

To lengthen or shorten the flap stays have to be opened. The walls with pivot pins are to press internally (1) and the walls with the holes are to press toward the outside (2). The chain links can be pushed together (3), or be pulled apart.

Installation of the flap stays

The assembly of the flap stays can take place before or after cable lining. Therefore energy chain does not need to be opened. The flap stays are inserted from the outside chain link floor until snap (1), (2). The dismantling of the stays is done by unlocking the tongue and pushing out (3).

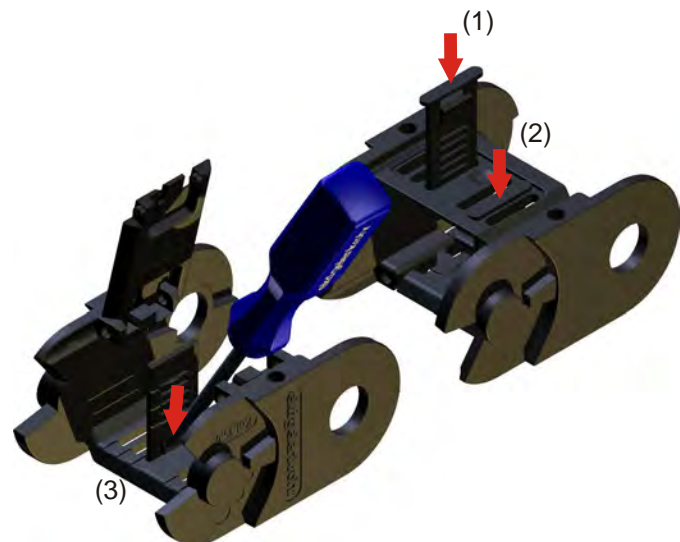
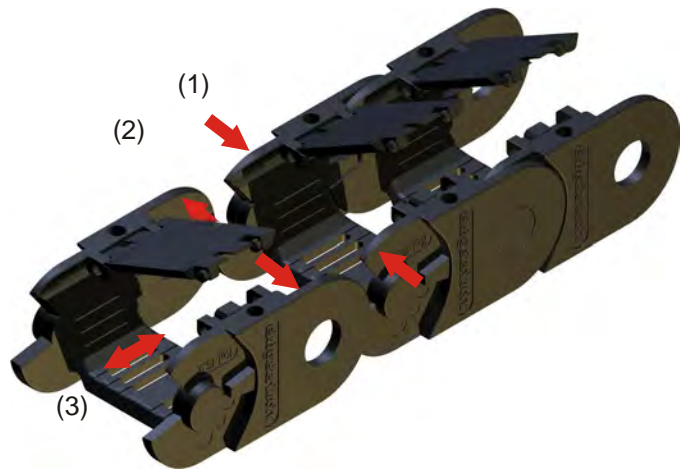

Assembly of horizontal dividers

The horizontal dividers (notched, telescopic and ladder-stay) are horizontally slid onto the vertical dividers (PZ) (1).

With a screwdriver the locking tongue can be mounted (2) and horizontal dividers disassembled (3).

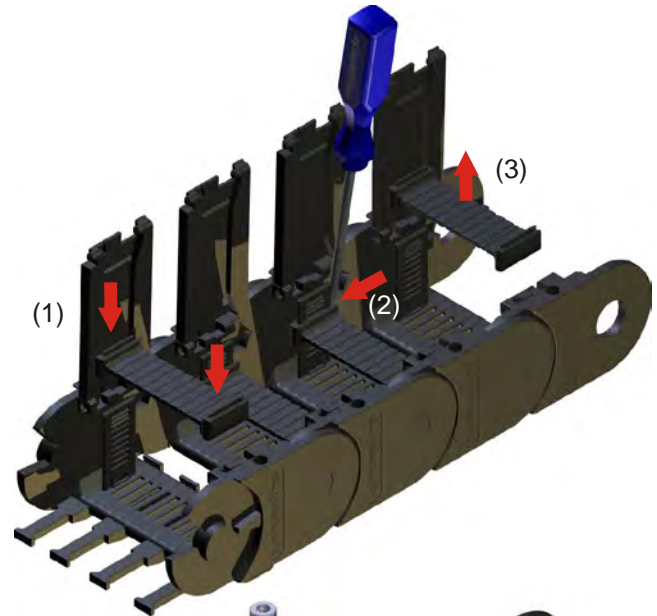

Mounting the energy chain and strain relief

Before mounting the energy chain horn stays may be assembled which can be used to fix the lines via cable ties. For most applications variable strain relief is recommended, to mount the anchor profile with the energy chain using the integrated connector. (1), (2).

It is also possible to attach the anchor profile as a separate strain relief. The anchor profile is suitable for various strain relief components (see design guidelines).

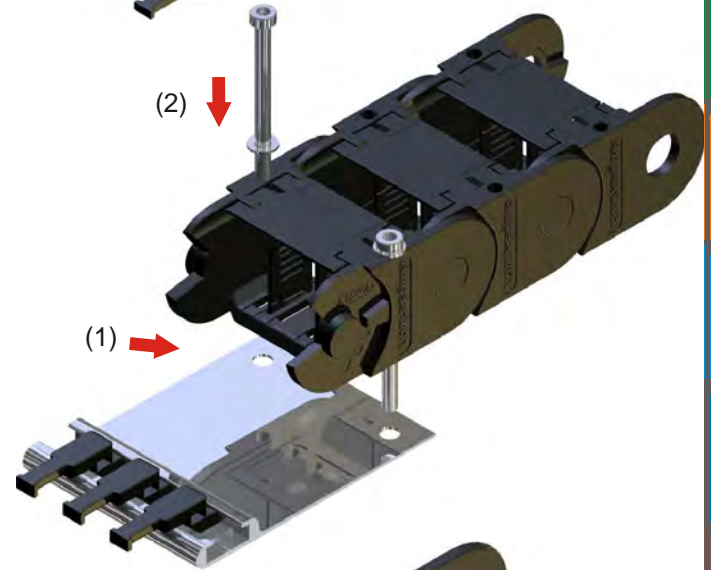

Snap assembly

The energy chain may be assembled with only one click using the Snap connector. Horn stays will be clipped at the stays as strain relief elements. After that the energy chain can be clicked in the designated position.

Alternatively, it is possible to mount the cable chains with flush mountig flange type brackets (1).

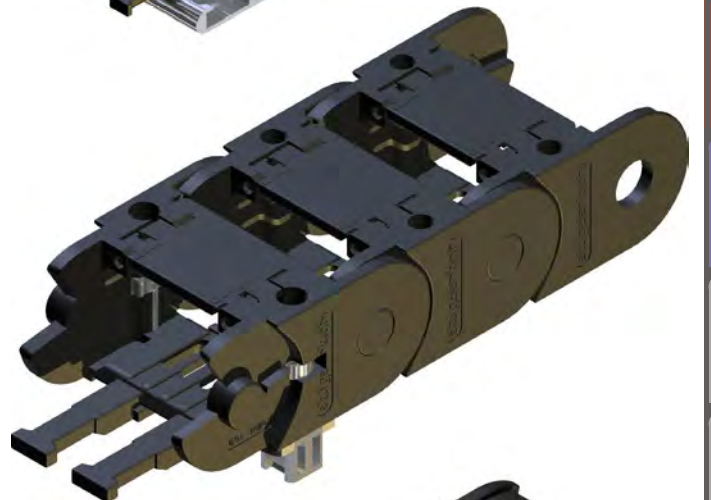

Maintenance of the energy chain

Kolibri energy chains are maintenance free. Like every mechanical system there will - depending on the ambient conditions - wear which must be observed. In case of this the energy chainspace has to be exchanged.

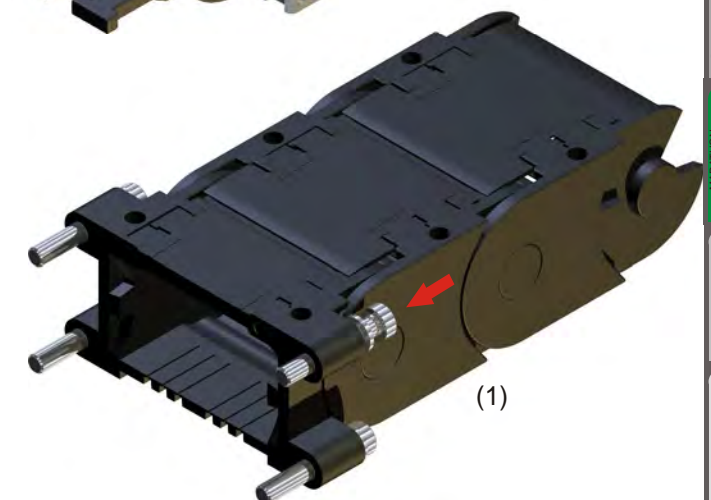

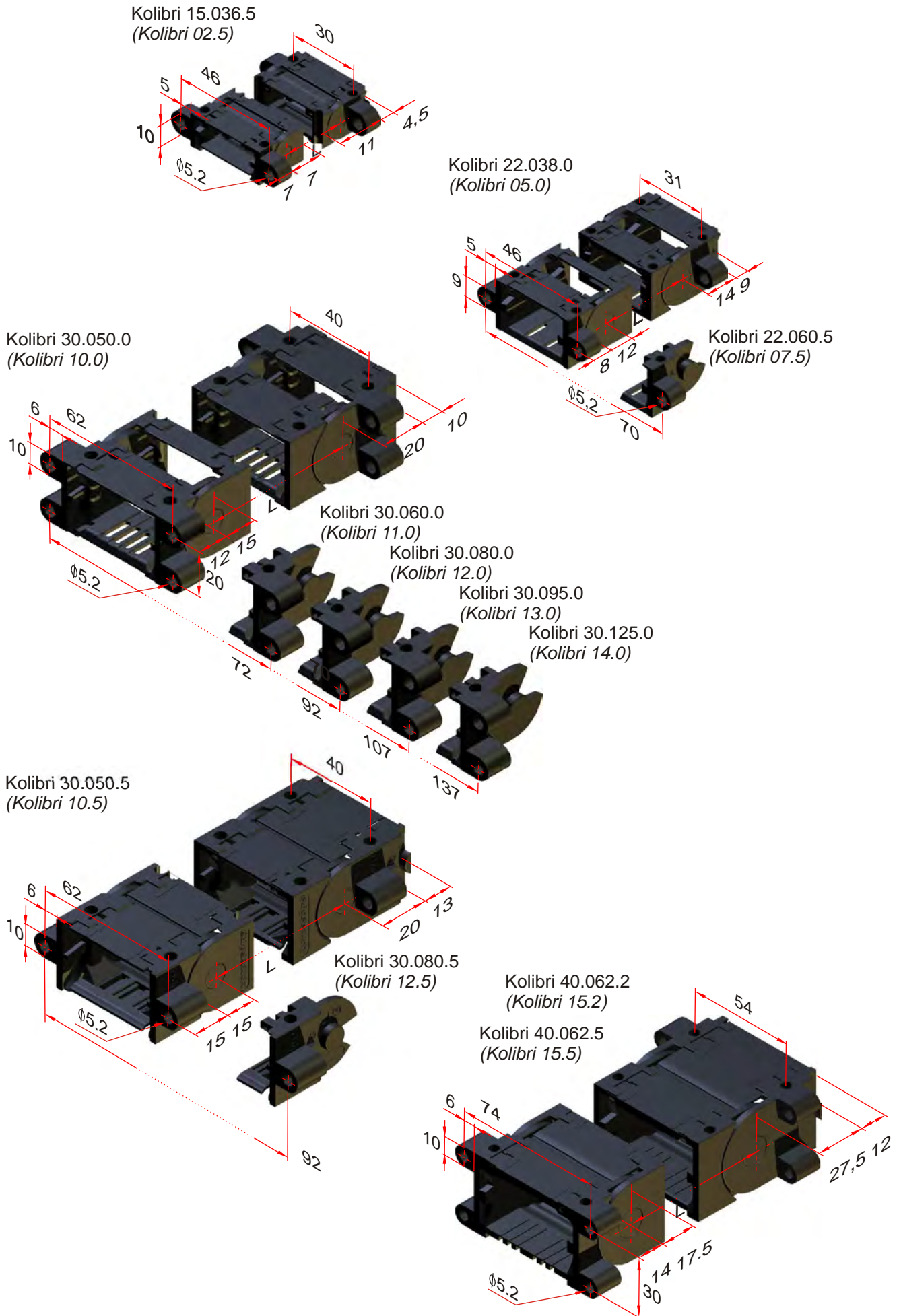

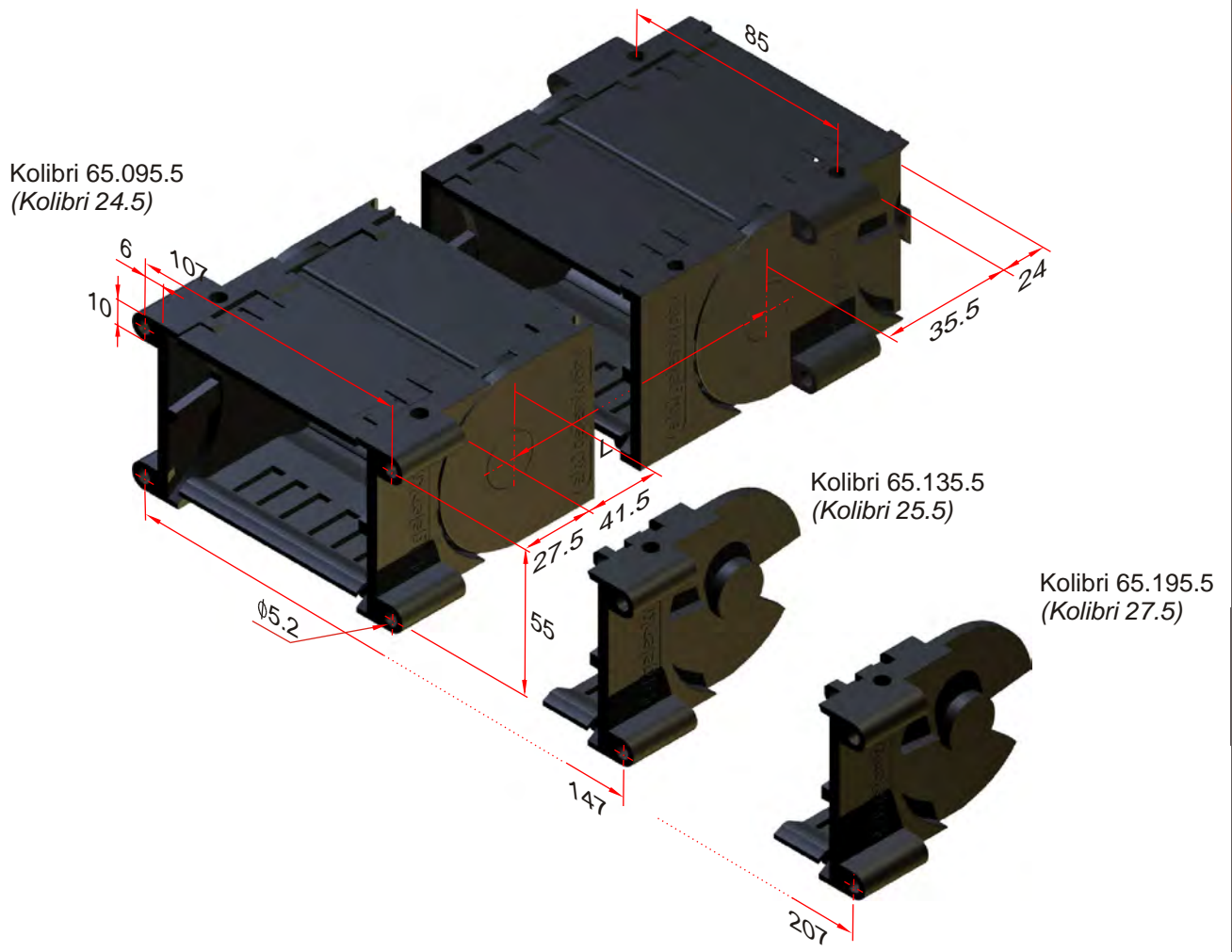
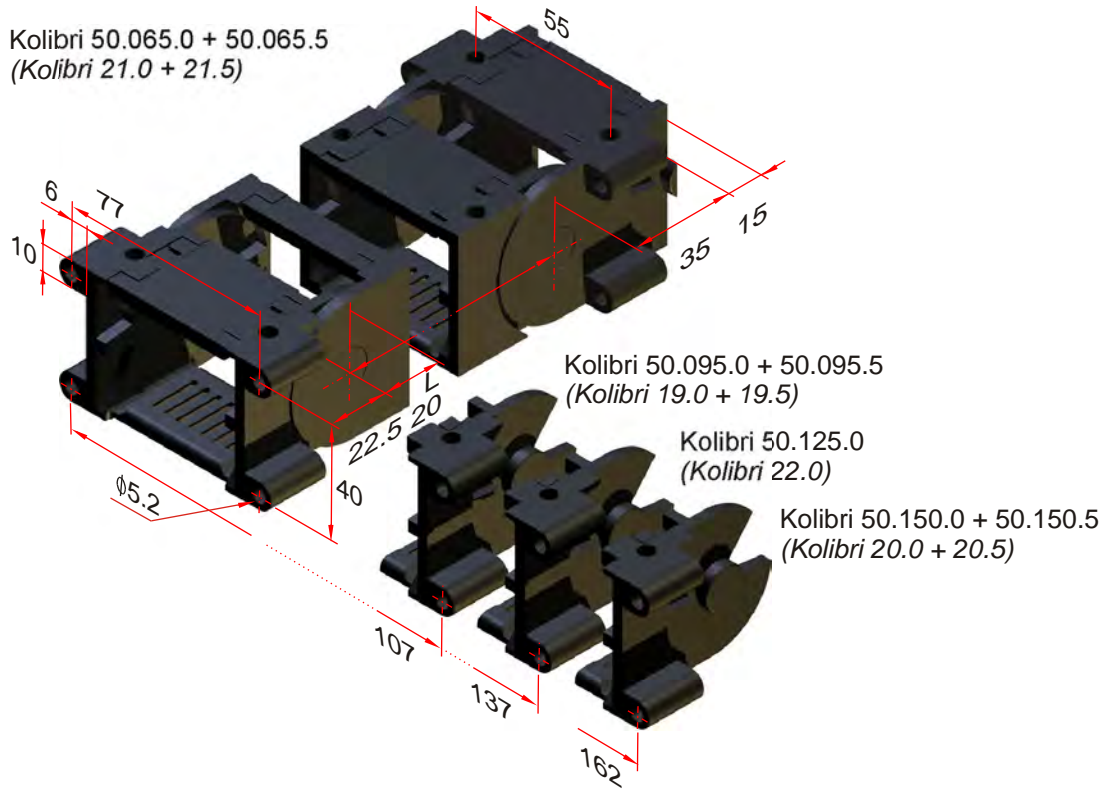

Kolibri parts 39



Kolibri
 Radius 15 17.5 20 30 35 40 50 60 70 75 100 125 150 175 200 250 300 400

10.012.4 (00.3)1089 -	-	1090	-	-	1091	-	-	-	-	-	-	-	-	-	-	-	-	-
13.023.4 short -	-	-	2164	-	-	-	-	-	-	-	-	-	-	-	-	-	-	-
13.023.4 long - 2137	-	-	2138	-	2139 (R55)	2140 (R80)	2141	-	-	-	-	-	-	-	-	-	-	-
15.015.3 (0) - 1056	0435	0029	-	-	-	-	-	-	-	-	-	-	-	-	-	-	-	-
15.015.4 (0.3) -	1116	1060	-	-	-	-	-	-	-	-	-	-	-	-	-	-	-	-
15.036.5 (02.5) -	-	1156	-	-	1157	-	-	-	-	-	-	-	-	-	-	-	-	-
15.037.3 (02) -	2191 ¹⁾	1983	-	-	-	-	-	-	-	-	-	-	-	-	-	-	-	-
15.051.0 (03) -	-	0845	-	-	-	-	-	-	-	-	-	-	-	-	-	-	-	-
22.025.4 (04.3) -	-	-	0981	-	-	-	0982	-	0983	-	-	-	-	-	-	-	-	-
22.038.0 (05.0) -	-	-	1686	-	1685	1684	-	1683	-	-	-	-	-	-	-	-	-	-
22.038.1 -	-	-	1876	-	-	-	-	-	-	-	-	-	-	-	-	-	-	-
22.048.0 (06) -	-	-	0840	-	-	-	0841	-	-	-	-	-	-	-	-	-	-	-
22.060.5 (07.5) -	-	-	-	-	1259	-	-	-	-	-	-	-	-	-	-	-	-	-
30.030.3 (1) -	-	-	-	0457	-	-	-	-	0004	-	-	-	-	-	-	-	-	-
30.060.3 (2) -	-	-	-	0006	-	-	-	-	0007	-	0615	-	0008	-	-	-	-	-
30.050.0 (10.0) -	-	-	-	1224	-	1430	-	1225	1222	-	1226	-	1223	-	-	-	-	-
30.050.1 (10.1) -	-	-	-	-	-	2106	-	1835	1748	-	-	-	-	-	-	-	-	-
30.050.5 (10.5) -	-	-	-	-	-	1002	-	1010	1003	-	1011	-	1004	-	-	-	-	-
30.060.0 (11.0) -	-	-	-	1229	1377	-	-	1230	1227	-	1231	-	-	-	-	-	-	-
30.060.1 (11.1) -	-	-	-	-	-	-	-	1944	1750	-	-	-	-	-	-	-	-	-
30.080.0 (12.0) -	-	-	-	1235	-	-	-	1236	1232	-	1233	-	1234	-	-	-	-	-
30.080.1 (12.2) -	-	-	-	-	-	-	-	1394	1621	-	-	-	-	-	-	-	-	-
30.080.2 -	-	-	-	-	-	-	-	-	-	-	-	-	-	-	-	-	-	-
30.080.4 -	-	-	-	-	-	-	-	-	-	-	-	-	-	-	-	-	-	-
30.080.5 (12.5) -	-	-	-	-	-	1798	-	-	1795	-	1796	-	1797	-	-	-	-	-
30.095.0 (13.0) -	-	-	-	1239	-	-	-	1240	1237	1324	1241	-	1238	-	-	-	-	-
30.095.1 (13.1) -	-	-	-	1992	-	-	-	1411	1645	1993	1994	-	1995	-	-	-	-	-
30.125.0 (14.0) -	-	-	-	1245	-	-	-	1246	1242	-	1243	-	1244	-	-	-	-	-
30.125.1 (14.1) -	-	-	-	1973	-	-	-	1974	1975	-	-	-	-	-	-	-	-	-
40.062.2 (15.0) -	-	-	-	-	-	1489	-	1490	1491	-	1492	-	1493	-	-	-	-	-
40.062.5 (15.5) -	-	-	-	-	-	-	-	1152	1163	-	-	-	-	-	-	-	-	-
40.075.2 (16.0) -	-	-	-	-	-	1484	-	1485	1486	-	1487	-	1488	-	-	-	-	-
40.075.6 -	-	-	-	-	-	2056	-	2055	2054	-	2053	-	2052	-	-	-	-	-
50.065.0 (21.0) -	-	-	-	-	-	-	-	0971	0972	1256	0973	-	0974	0975	-	-	-	-
50.065.5 (21.5) -	-	-	-	-	-	-	-	-	1005	-	1006	-	1007	1008	-	-	-	-
50.095.0 (19.0) -	-	-	-	-	-	-	-	1138	1148	1431	1139	1325	1140	1141	-	-	-	-
50.095.1 (19.1) -	-	-	-	-	-	-	-	1947	1948	1949	1950	1951	1952	2016	-	-	-	-
50.095.2 (19.2) -	-	-	-	-	-	-	-	1619	1644	1483	1370	-	-	-	-	-	-	-
50.095.5 (19.5) -	-	-	-	-	-	-	-	-	1012	-	1013	-	1014	1016	-	-	-	-
50.125.0 (22.0) -	-	-	-	-	-	-	-	1292	1288	2158	1289	-	1290	1291	-	-	-	-
50.125.1 (22.1) -	-	-	-	-	-	-	-	1928	-	2415	2373	-	-	-	-	-	-	-
50.150.0 (20.0) -	-	-	-	-	-	-	-	1287	1283	-	1284	-	1285	1286	-	-	-	-
50.150.1 (20.1) -	-	-	-	-	-	-	-	1516	2447	-	2051	-	2109	2112	-	-	-	-
50.150.5 (20.5) -	-	-	-	-	-	-	-	-	1061	-	1062	-	1063	1064	-	-	-	-
65.095.1 (24.1) -	-	-	-	-	-	-	-	-	-	1252	1253	-	1254	-	1255	-	-	-
65.095.5 (24.5) -	-	-	-	-	-	-	-	-	-	1084	1085	-	1086	-	1087	-	-	-
65.135.1 (25.1) -	-	-	-	-	-	-	-	-	-	1753	1754	-	1755	-	1756	1757	-	-
65.135.5 (25.5) -	-	-	-	-	-	-	-	-	-	1076	1077	-	1078	-	1079	1752	-	-
65.195.1 (27.1) -	-	-	-	-	-	-	-	-	-	1758	1922	-	1759	-	1760	-	-	-
65.195.5 (27.5) -	-	-	-	-	-	-	-	-	-	1080	1081	-	1082	-	1083	-	-	-

¹⁾ R24
44

Kolibri PART NUMBERS

special material parts like UI94 V-0, EX or other have to be named in the order





Kolibri

Kolibri	11	12	stay thickness	2 mm	3 mm	10	2 mm	2 mm	4 mm	9	2 mm	3 mm	4 mm	4 mm
10.012.4	-	-	-	-	-	-	-	-	-	-	-	-	-	-
13.023.4	-	-	-	-	-	-	-	-	-	-	-	-	-	-
13.023.4	-	-	-	-	-	-	-	-	-	-	-	-	-	-
15.015.3	-	-	-	-	-	-	-	-	-	-	-	-	-	-
15.015.4	-	-	-	-	-	-	-	-	-	-	-	-	-	-
15.036.5	-	1708	-	-	-	-	-	-	-	-	-	-	-	-
15.037.3	-	-	-	-	-	-	-	-	-	-	-	-	-	-
15.051.0	1707	-	-	-	-	-	-	-	-	-	-	-	-	-
22.025.4	-	-	-	-	-	-	-	-	-	-	-	-	-	-
22.038.0	1687	-	1688	-	-	-	-	-	-	-	-	-	-	-
22.038.1	1687	-	1688	-	-	-	-	-	-	-	-	-	-	-
22.048.0	1707	-	-	-	-	-	-	-	-	-	-	-	-	-
22.060.5	-	1709	1294	-	-	-	-	-	-	-	-	-	-	-
30.030.3	-	-	-	-	-	-	-	-	-	-	-	-	-	-
30.060.3	-	-	-	-	-	-	-	-	-	-	-	-	-	-
30.050.0	1698	-	-	1258	-	-	-	-	-	-	-	-	-	-
30.050.1	1698	-	-	1258	-	-	-	-	-	-	-	-	-	-
30.050.5	-	1710	-	-	1017	-	-	-	-	-	-	-	-	-
30.060.0	1697	-	-	1258	-	-	-	-	-	-	-	-	-	-
30.060.1	1697	-	-	1258	-	-	-	-	-	-	-	-	-	-
30.080.0	1695	-	-	1258	-	-	-	-	-	-	-	-	-	-
30.080.1	1695	-	-	1258	-	-	-	-	-	-	-	-	-	-
30.080.2	1695	-	-	-	-	-	-	-	-	-	-	-	-	-
30.080.4	-	-	-	-	-	-	-	-	-	-	-	-	-	-
30.080.5	-	-	-	-	1017	-	-	-	-	-	-	-	-	-
30.095.0	1696	-	-	1258	-	-	-	-	-	-	-	-	-	-
30.095.1	1696	-	-	1258	-	-	-	-	-	-	-	-	-	-
30.125.0	1706	-	-	1258	-	-	-	-	-	-	-	-	-	-
30.125.1	1706	-	-	1258	-	-	-	-	-	-	-	-	-	-
40.062.2	1694	-	-	-	-	-	-	1521	-	-	-	-	-	-
40.062.5	-	1577	-	-	-	1268	-	-	-	-	-	-	-	-
40.075.2	1693	-	-	-	-	-	1521	-	-	-	-	-	-	-
40.075.6	1693	-	-	-	-	-	1521	-	-	-	-	-	-	-
50.065.0	1692	-	-	-	-	-	-	1113	-	-	-	-	-	-
50.065.5	-	1711	-	-	-	-	-	1113	-	-	-	-	-	-
50.095.0	1691	-	-	-	-	-	-	1113	-	-	-	-	-	-
50.095.1	1691	-	-	-	-	-	-	1113	-	-	-	-	-	-
50.095.2	1691	-	-	-	-	-	-	-	-	1451	-	-	-	-
50.095.5	-	1655	-	-	-	-	-	1113	-	-	-	-	-	-
50.125.0	1320	-	-	-	-	-	-	-	1326	-	-	-	-	-
50.125.1	1320	-	-	-	-	-	-	-	1326	-	-	-	-	-
50.150.0	1318	-	-	-	-	-	-	-	1326	-	-	-	-	-
50.150.1	1318	-	-	-	-	-	-	-	1326	-	-	-	-	-
50.150.5	-	1624	-	-	-	-	-	1113	-	-	-	-	-	-
65.095.1	1470	-	-	-	-	-	-	-	-	-	-	-	1129	-
65.095.5	-	1625	-	-	-	-	-	-	-	-	-	-	1129	-
65.135.1	1354	-	-	-	-	-	-	-	-	-	-	-	1129	-
65.135.5	-	1626	-	-	-	-	-	-	-	-	-	-	1129	-
65.195.1	1355	-	-	-	-	-	-	-	-	-	-	-	1129	-
65.195.5	-	1627	-	-	-	-	-	-	-	-	-	-	1129	-

Kolibri parts 39

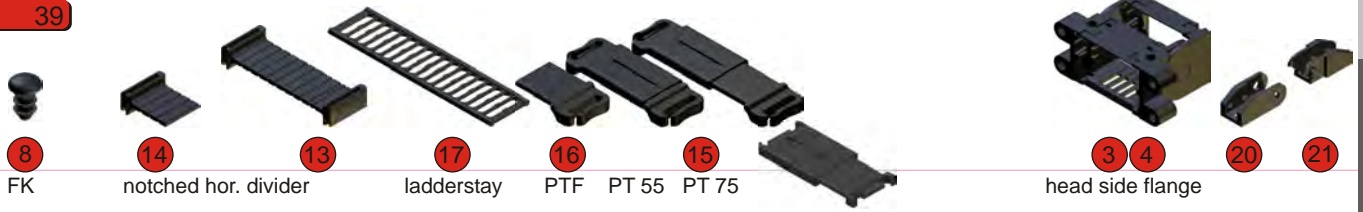
Kolibri parts 39



Kolibri	FK	notched hor. divider flying	ladderstay	PTF flying	PT 55 55-80	PT 75 75-100	head side flange	1576	1814
10.012.4	-	-	-	-	-	-	-	-	-
13.023.4	-	-	-	-	-	-	-	-	-
13.023.4	-	-	-	-	-	-	-	-	-
15.015.3	-	-	-	-	-	-	-	-	-
15.015.4	-	-	-	-	-	-	-	-	-
15.036.5	-	-	-	-	-	-	1339	-	-
15.037.3	-	-	-	-	-	-	-	-	-
15.051.0	-	-	-	-	-	-	-	-	-
22.025.4	-	-	-	-	-	-	-	-	-
22.038.0	-	-	-	-	-	-	1745	-	-
22.038.1	-	-	-	-	-	-	-	-	-
22.048.0	-	-	-	-	-	-	-	-	-
22.060.5	-	1127	-	-	-	-	1340	-	-
30.030.3	-	-	-	-	-	-	-	-	-
30.060.3	-	-	-	-	-	-	-	-	-
30.050.0	1363	-	-	-	-	-	1329	-	-
30.050.1	1363	-	-	-	-	-	1329	-	-
30.050.5	1363	1127	-	-	-	-	1341	-	-
30.060.0	1363	-	-	-	-	-	1330	-	-
30.060.1	1363	-	-	-	-	-	1330	-	-
30.080.0	1363	-	-	-	-	-	1331	-	-
30.080.1	1363	-	-	-	-	-	1331	-	-
30.080.2	1363	-	-	1665	1927	-	-	-	-
30.080.4	1363	-	-	-	-	-	1331	-	-
30.080.5	1363	1127	-	-	-	-	-	-	-
30.095.0	1363	-	-	-	-	-	1332	-	-
30.095.1	1363	-	-	-	-	-	1332	-	-
30.125.0	1363	-	-	-	-	-	1333	-	-
30.125.1	1363	-	-	-	-	-	1333	-	-
40.062.2	1363	-	-	1665	1927	-	1996 / 1997	-	-
40.062.5	1363	-	-	-	-	-	1343	-	-
40.075.2	1363	-	-	1665	1927	-	-	-	-
40.075.6	1363	-	-	1665	1927	-	-	-	-
50.065.0	1269	1127	-	-	-	-	1336	-	
50.065.5	1269	1127	-	-	-	-	1346	-	-
50.095.0	1269	1127	1127	-	-	-	1334	-	-
50.095.1	1269	1127	1127	-	-	-	1334	-	-
50.095.2	1269	-	-	1665	1927	-	-	-	-
50.095.5	1269	1127	1127	-	-	-	1344	-	-
50.125.0	1269	-	-	-	-	-	1337	-	-
50.125.1	1269	-	-	-	-	-	1337	-	-
50.150.0	1269	-	-	-	-	-	1335	-	-
50.150.1	1269	-	-	-	-	-	1335	-	-
50.150.5	1269	1127	1127	-	-	-	1345	-	-
65.095.1	1269	-	-	1665	1927	-	1347	-	-
65.095.5	1269	-	-	1665	1927	-	1347	-	-
65.135.1	1269	-	-	1665	1927	0879 0880	1348	-	-
65.135.5	1269	-	-	1665	1927	0879 0880	1348	-	-
65.195.1	1269	-	-	1665	1927	0879 0880	1349	-	-
65.195.5	1269	-	-	1665	1927	0879 0880	1349	-	-

Kolibri PART NUMBERS

Kolibri parts 39



Kolibri	anchor profile	ZL50	blue ribbon	ZLA 8	(PZ SLP220)	ZHS10	ZLS10	HS55	HS65	HS75	HS85
10.012.4	-	-	-	-	-	-	-	-	-	-	-
13.023.4	-	-	-	-	-	-	-	-	-	-	-
13.023.4	-	-	-	-	-	-	-	-	-	-	-
15.015.3	-	-	-	-	-	-	-	-	-	-	-
15.015.4	-	-	-	-	-	-	-	-	-	-	-
15.036.5	-	-	-	-	-	-	-	-	-	-	-
15.037.3	-	-	-	-	-	-	-	-	-	-	-
15.051.0	-	-	-	-	-	-	-	-	-	-	-
22.025.4	1163	-	1142	1159	0778	1407	1160	-	-	-	-
22.038.0	1163	-	1142	1159	0778	1407	1160	-	-	-	-
22.038.1	1163	-	1142	1159	0778	1407	1160	-	-	-	-
22.048.0	1163	-	1142	1159	0778	1407	1160	-	-	-	-
22.060.5	1163	-	1142	1159	0778	1407	1160	-	-	-	-
30.030.3	1163	-	1142	1159	0778	1407	1160	-	-	-	-
30.060.3	1163	-	1142	1159	0778	1407	1160	-	-	-	-
30.050.0	1163	-	1142	1159	0778	1407	1160	1802	-	-	-
30.050.1	1163	-	1142	1159	0778	1407	1160	1802	-	-	-
30.050.5	1163	-	1142	1159	0778	1407	1160	-	-	-	-
30.060.0	1163	-	1142	1159	0778	1407	1160	1802	-	-	-
30.060.1	1163	-	1142	1159	0778	1407	1160	1802	-	-	-
30.080.0	1163	-	1142	1159	0778	1407	1160	1802	1503 ¹⁾	-	1812 ¹⁾
30.080.1	1163	-	1142	1159	0778	1407	1160	1802	1503 ¹⁾	-	1812 ¹⁾
30.080.2	1163	-	1142	1159	0778	1407	1160	-	1503	-	1812
30.080.4	1163	-	1142	1159	0778	1407	1160	-	1503	-	1812
30.080.5	1163	-	1142	1159	0778	1407	1160	-	-	-	-
30.095.0	1163	-	1142	1159	0778	1407	1160	1802	-	-	-
30.095.1	1163	-	1142	1159	0778	1407	1160	1802	-	-	-
30.125.0	1163	-	1142	1159	0778	1407	1160	1802	-	-	-
30.125.1	1163	-	1142	1159	0778	1407	1160	1802	-	-	-
40.062.2	1163	-	1142	1159	0778	1407	1160	-	1503	-	1812
40.062.5	1163	-	1142	1159	0778	1407	1160	-	-	-	-
40.075.2	1163	-	1142	1159	0778	1407	1160	-	1503	-	1812
40.075.6	1163	-	1142	1159	0778	1407	1160	-	1503	-	1812
50.065.0	1163	1273	1142	1159	-	1407	1160	-	-	1504	-
50.065.5	1163	1273	1142	1159	-	1407	1160	-	-	-	-
50.095.0	1163	1273	1142	1159	-	1407	1160	-	1503 ¹⁾	1504	1812 ¹⁾
50.095.1	1163	1273	1142	1159	-	1407	1160	-	1503 ¹⁾	1504	1812 ¹⁾
50.095.2	1163	1273	1142	1159	-	1407	1160	-	1503	-	1812
50.095.5	1163	1273	1142	1159	-	1407	1160	-	-	-	-
50.125.0	1163	1273	1142	1159	-	1407	1160	-	-	1504	-
50.125.1	1163	1273	1142	1159	-	1407	1160	-	-	1504	-
50.150.0	1163	1273	1142	1159	-	1407	1160	-	-	1504	-
50.150.1	1163	1273	1142	1159	-	1407	1160	-	-	1504	-
50.150.5	1163	1273	1142	1159	-	1407	1160	-	-	-	-
65.095.1	1163	1273	1142	1159	-	1407	1160	-	-	-	-
65.095.5	1163	1273	1142	1159	-	1407	1160	-	-	-	-
65.135.1	1163	1273	1142	1159	-	1407	1160	-	-	-	-
65.135.5	1163	1273	1142	1159	-	1407	1160	-	-	-	-
65.195.1	1163	1273	1142	1159	-	1407	1160	-	-	-	-
65.195.5	1163	1273	1142	1159	-	1407	1160	-	-	-	-

¹⁾ with horn stay connectors

PKK

- PKK applications 49
- PKK dimensions 50
- PKK types 52
- PKK sizes 54
- PKK parts 55
- PKK assembly 56
- PKK article numbers 62



closed + open

PKK CHARACTERISTICS

A development from many years of experience, which combines all the advantages of plastic energy chains to one system:

- positive locking stays
- fast stay assembly and disassembly
- easy to shorten and lengthen
- the three-dimensional chain

All ekd plastic energy chains are equipped with the integrated plastic connector. Additional components for attaching the energy chain are not required.

Dimensions

bending radii:	40	to	500 mm
inner height:	16	to	80 mm
inner width:	30	to	400 mm
energy chain weight:	0.6	to	3.4 kg / m
(see dimensions)			

Travel

The maximum range of travel is determined by the arrangement and the additional weight (line weight). At normal arrangement the maximum travel is double free carrying length. Support rollers or similar constructive steps can increase this value. Travel distances up to 100 meters are possible (see chapter on design guidelines).

Travel speed

There are no limits for the travel speed in general. But at gliding arrangements application specific influences have to be taken into account.

Acceleration

The acceleration is not subject to any restriction. Boundaries can only be achieved at high line tension forces encountered by the weights.

Temperature

Long term temperature limits are inbetween -20°C and 100°C.

Special versions

- | | |
|----------|------------------------|
| ELTOLA | ... silent running |
| ALLROUND | ... all movements |
| ATEX | ... EX-protection |
| ESD | ... antistatic |
| V-0 | ... self extinguishing |

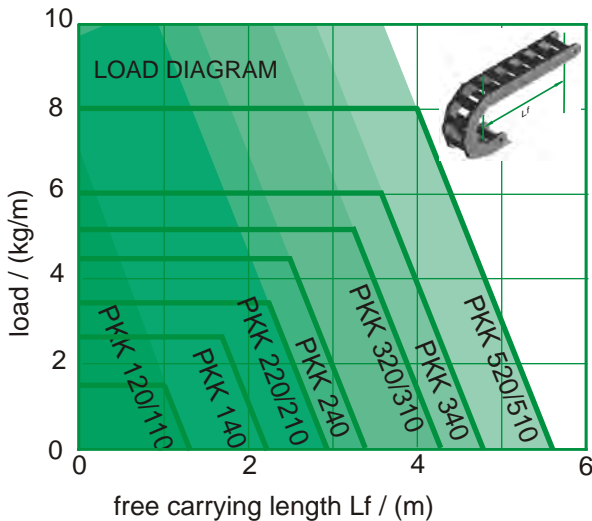

APPLICATION AREAS

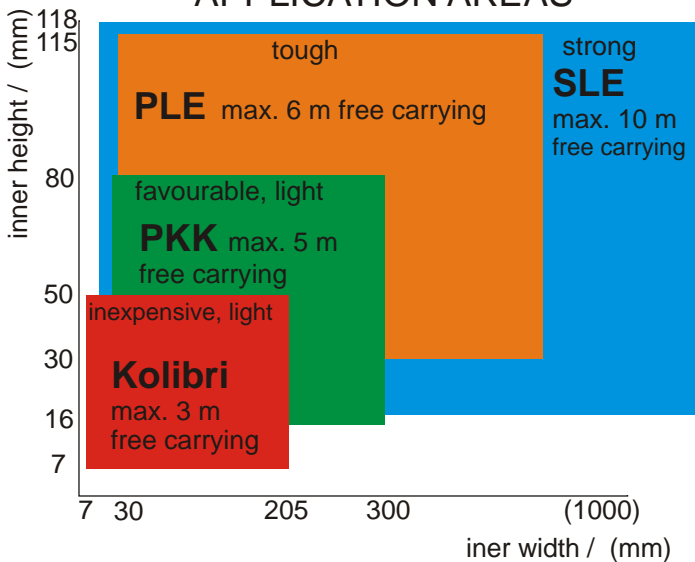

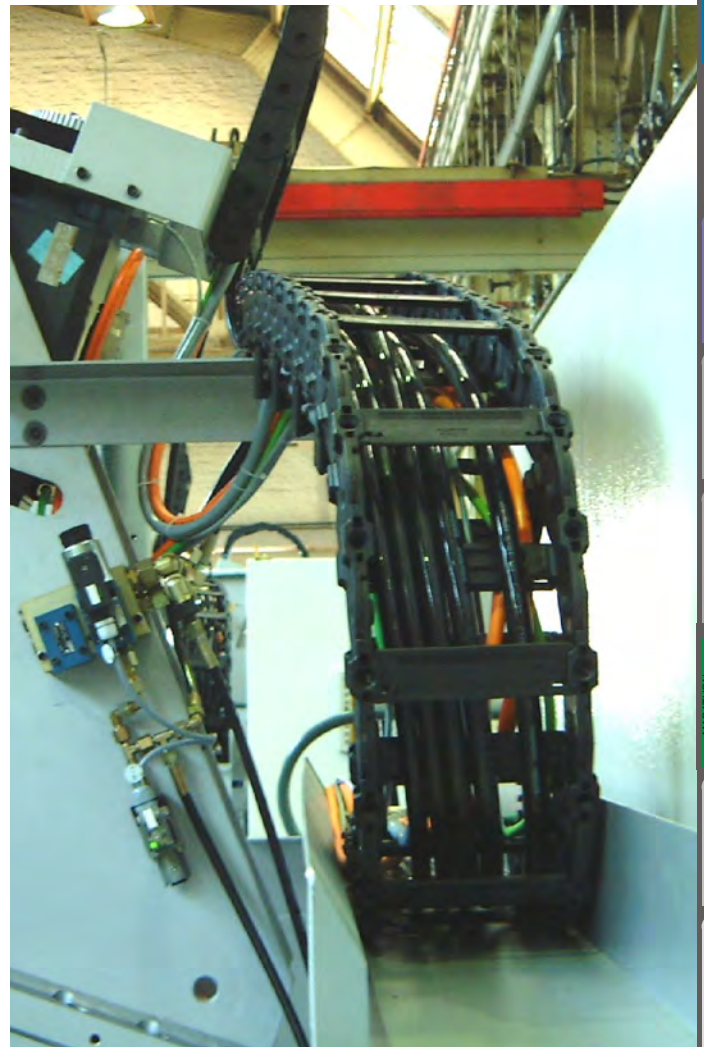

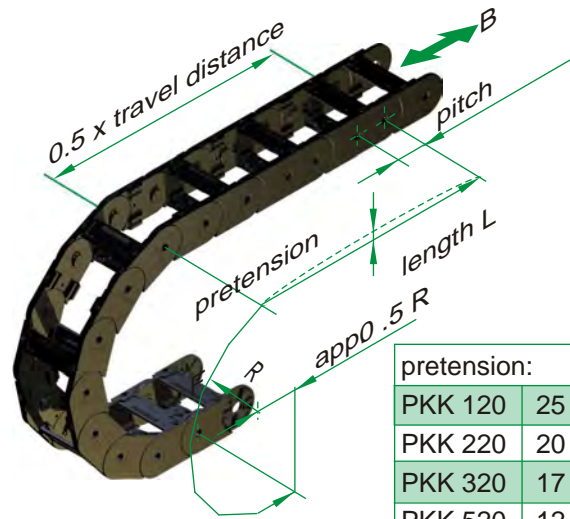
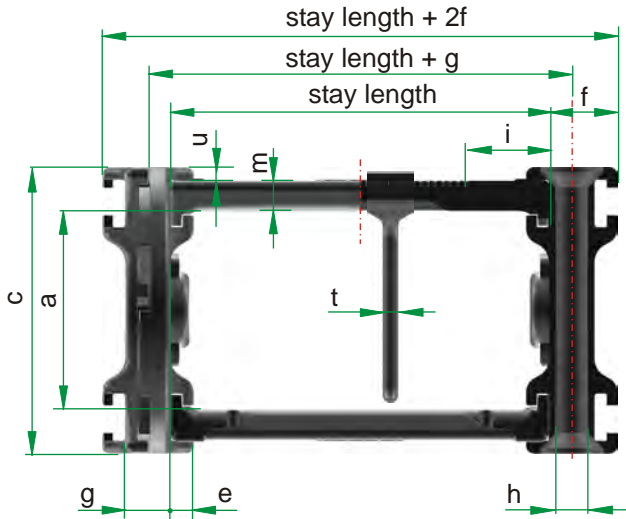

pretension:	
PKK 120	25 +/- 4 mm/m
PKK 220	20 +/- 4 mm/m
PKK 320	17 +/- 4 mm/m
PKK 520	12 +/- 4 mm/m



additional stay		v	r	s
PKK 113, 123, 143		19		16
PKK 213, 223, 243	short	19,5	14,5	-
		39	-	34
PKK 313, 323, 343	short	29,5	21	-
		59	-	51
PKK 513, 523	short	29,5	21	-
		59	-	51

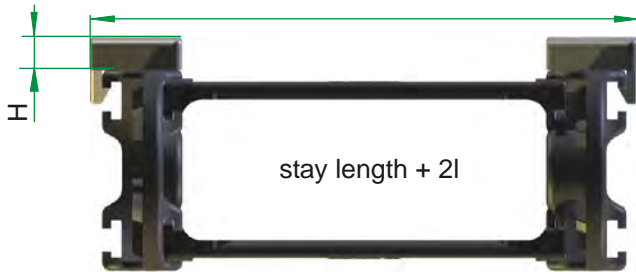

slider	(see p.64) part no.	H	l	radius
PKK 225	1740	5	18	100 150 200 250 300
PKK 228	0402	5	18	100 150
PKK 228	1742	8	18	200 250 300
PKK 325	1741	5	21	150 200 250 300 400
PKK 328	0432	5	21	150 200 250 300 400
PKK 328	1632	8	21	250 300 400
PKK 528	1800	8	23	200 250 300 400 500
PKK 528	1801	8	23	300 400 500

friction coefficient: 0.2 to 0.25

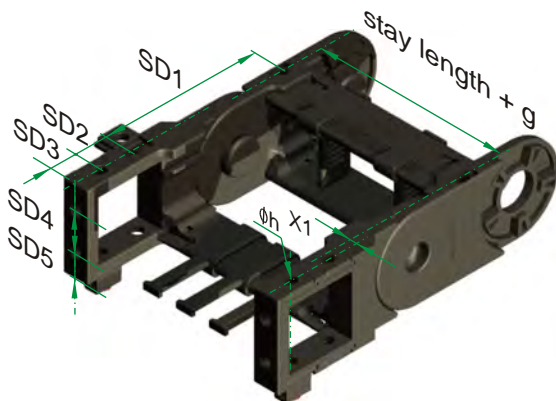

SD flange	X1	SD1	SD2	SD3	SD4	SD5
PKK 140	0	54	28	15	20	10
PKK 210	2,5	85	22,5	15	22	14
PKK 220	2,5	85	22,5	15	22	14
PKK 310	3	119	35	20	30-35	22,5
PKK 320	3	119	35	20	30-35	22,5
PKK 340	3	119	35	20	40-45	20

PKK	pitch	a	c	e ¹⁾	f	g	h	i ²⁾	m ³⁾	t	u	weight (stay 100) kg/m				
120 , 121,123, 125	35	16	25	3	11	8	Ø4	15	3	2	1.5				0.60	
110, 111, 113, 115	35	16	25	3	8	8	Ø4	15	3	2	1.5				0.60	
140, 141, 143	54	30	40	3	9	9	Ø4	15	3	3	2				1.03	
220 , 221, 223, 225, 228	65	34	50	5	15	10	Ø6	15	5	4	3				1.50	
210, 211, 213, 215	65	34	50	5	10	10	Ø6	15	5	4	3				1.40	
240, 241, 243, 245	65	44	60	5	10	10	Ø6	15	5	4	3				1.70	
320 , 321, 323, 325, 328	90	51	75	6	18	12	Ø8	20	8	4	4				2.50	
310, 311, 313, 315	90	51	75	6	12	12	Ø8	20	8	4	4				2.50	
340, 341, 343, 345	90	61	85	6	15	15	Ø8	20	8	4	3.5				2.70	
520 , 521, 523, 525, 528	115	80	104	6	20	14	Ø8	20	8	4	3.5				3.40	
510, 511, 513, 515	115	80	104	6	14	14	Ø8	20	8	4	3.5				3.20	
bending radius R [mm]																
120 , 121,123,125 ⁴⁾	40	50	60	75												
110, 111, 113, 115 ⁴⁾	40	50	60	75												
140, 141 143		50	60	80	100		150		200							
220 , 221, 223, 225 ⁴⁾ , 228 ⁶⁾				75	100		150		200	250	300					
210, 211, 213, 215 ⁴⁾				65	75	100	125	150	200	250	300					
240, 241, 243, 245 ⁴⁾				75	100	120	150		200	250	300					
320 , 321, 323, 325 ⁴⁾ , 328 ⁶⁾					100		150		200	250	300	400				
310, 311, 313, 315 ⁴⁾					100	130	150		200	250	300	400				
340, 341, 343, 345 ⁴⁾					100		150		200	250	300	400				
520 , 521, 523, 525 ⁴⁾ , 528 ⁶⁾							150		200	250	300	400	500			
510, 511, 513, 515 ⁴⁾							150		200	250	300	400	500			
stay length [mm] ¹⁾																
120 ,110,111,113,121,123	30	50	60	70	80	90	100	110	120							
115, 125		50					100									
140, 141, 143	30	50	60	70	80	90	100	110	120							
220 ,210,211,213,221,223,228		50	60	70	80	90	100	110	120	130	150	170		200	220	
215, 225 ⁵⁾		50					100				150			200		
240, 241, 243		50	60	70	80	90	100	110	120	130	150	170		200	220	
245 ⁵⁾		50					100				150			200		
320 ,310,311,313,321,323,328		50	60	70	80	90	100		120	130	150	170	180	200		230 250 270 300 330 400
315, 325 ⁵⁾							100				150			200		300
340, 341, 343		50	60	70	80	90	100		120	130	150	170	180	200		230 250 270 300 330 400
345 ⁵⁾							100				150			200		300
520 ,510,511,513,521,523,528		50	60	70	80	90	100		120	130	150	170	180	200		230 250 270 300 330 400
515, 525											150			200		

- 1) The usable interior width is stay length - 2e minus the width of the used PZ
- 2) First latching the PZ (latching all 2mm); PKK 215,225,245, 315, 325, 345 i=22;
- 3) Dimension does not apply to the closed type
- 4) PKK 115 and 125 from R50, 215 and 225 from R100, 245, 315 and 325 from R150, 345, 525 and 515 from R200
- 5) The inner radius covers (ASI) of length 200 mm of the PKK 215, 225, 245 and 300 mm and 200 mm of the PKK 315, 325, 345 are designed with a pivot on one side.
- 6) PKK 228 from R100, PKK 328 from R150, PKK 528 from R200

PKK TYPES

PKK 120, 220, 320, 520

The standard version has a stay in every second link. With additional link bands and stays the chains can be extended as multibandchains. The **integrated connector** makes each link in the chain to a mounting link.

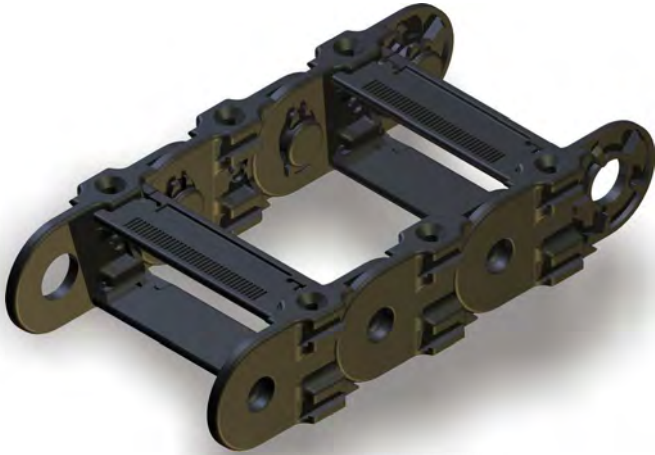

order example

PKK 220	/ 100	x	3510	/	100
type	radius		length		stay length

PKK 110, 140, 210, 240, 310, 340, 510

The smooth designed PKK corresponds to the standard version, but has no exterior T-slot. These types provide a very good visual effect and a smaller width through the flat outside surfaces (also see PKK 215, PKK 245). The PKK 240 and 340 offer larger cross sections due to the increased link height.

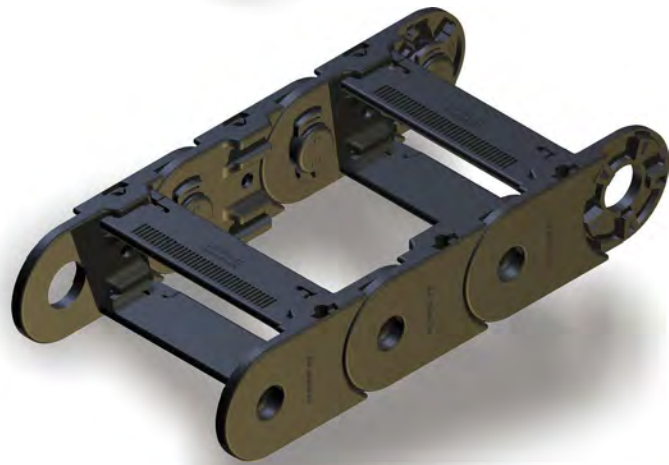

order example

PKK 240	/ 100	x	3510	/	100
type	radius		length		stay length

PKK 121, 221, 321, 521

The types PKK -21 are manufactured with a stay in each link. The additional stays increase the lateral stability and optimize guiding of particularly smaller cable diameter.

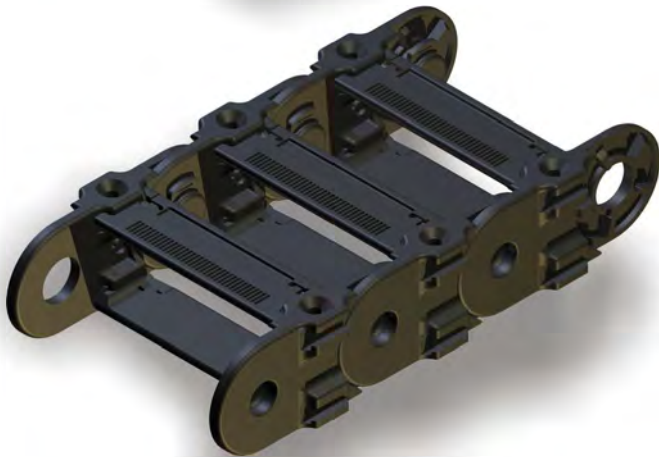

order example

PKK 221	/ 100	x	3510	/	100
type	radius		length		stay length

PKK 111, 141, 211, 241, 311, 341, 511

These are the smooth designs with a stay in each link to increase lateral stability and optimize guiding of particularly small cables. PKK 241 and PKK 341 have a higher capacity due to their increased link height.

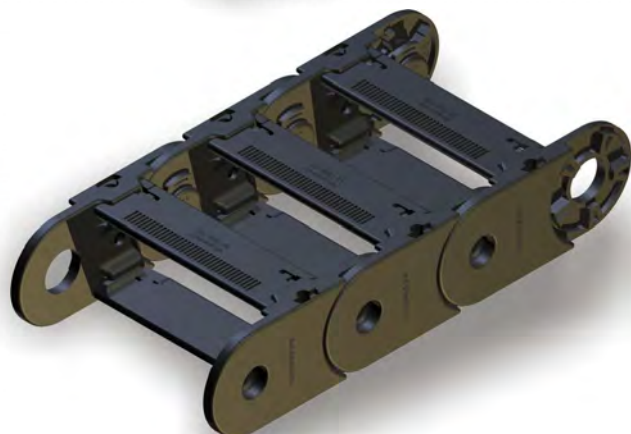

order example

PKK 241	/ 100	x	3510	/	100
type	radius		length		stay length

PKK 113, 123, 143, 213, 223, 243, 313, 323, 343, 513, 523

The PKK with extension stays in the inner radius. Suitable for low speeds these stays create additional space. The extension stays can be arranged in the outer radius or in other combinations as per optional drawing. The extension stays are available in two lengths.

order example			
PKK 223	/ 100	x 3510	/ 100
type	radius	length	stay length

PKK 125, 225, 325, 525

The closed designs offer optimum protection of the lines against chips or against UV radiation. The covers can be opened in the inner or outer radius. The closed types may also be subsequently created from the standard version.

PKK 115, 215, 245, 315, 345, 515

Without T-slot on the outside, the closed types achieve a good visual effect with their flat sides and a smaller width.

order example			
PKK 215	/ 100	x 3510	/ 100
type	radius	length	stay length

PKK 228, 328, 528

The PKK 128, 228 and 328 with sliders are designed for gliding arrangements (long travel distances) and are fitted with stays in each link. The sliders are mounted in the inner radius of the energy chain and have a very low coefficient of friction ($\mu = 0.2$ to 0.25).

The sliders can also be installed afterwards. At low stroke rates and low speeds (<1m / s) sliders are not necessary. The smallest radius of each dimension of the PKK is not suitable for sliders.

order example			
PKK 228	/ 100	x 3510	/ 100
type	radius	length	stay length

Multiband energy chains

Multiband energy chains can be created by attaching additional link bands. These are assembled through stays at standard energy chains (see assembly, except PKK with smooth exteriors).

order example			
PKK 220	/ 100	x 3510	/ 100 / 100
type	radius	length	stay length / stay length

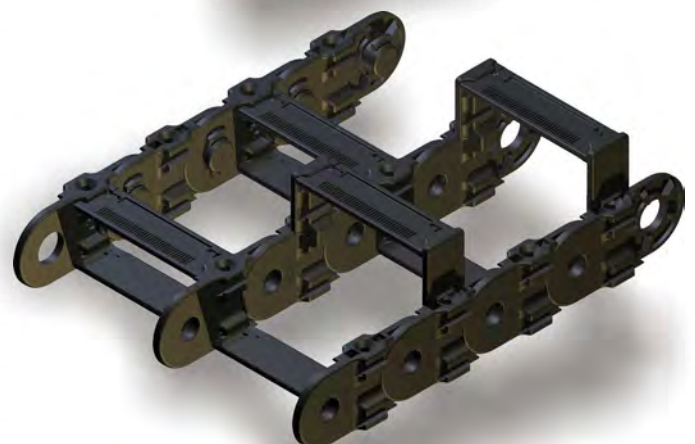
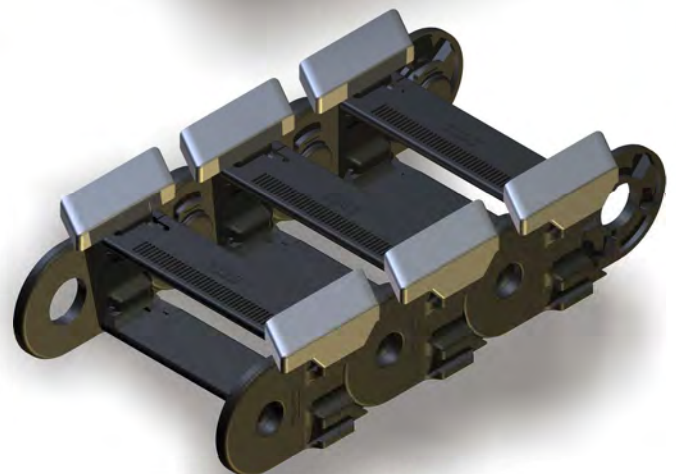
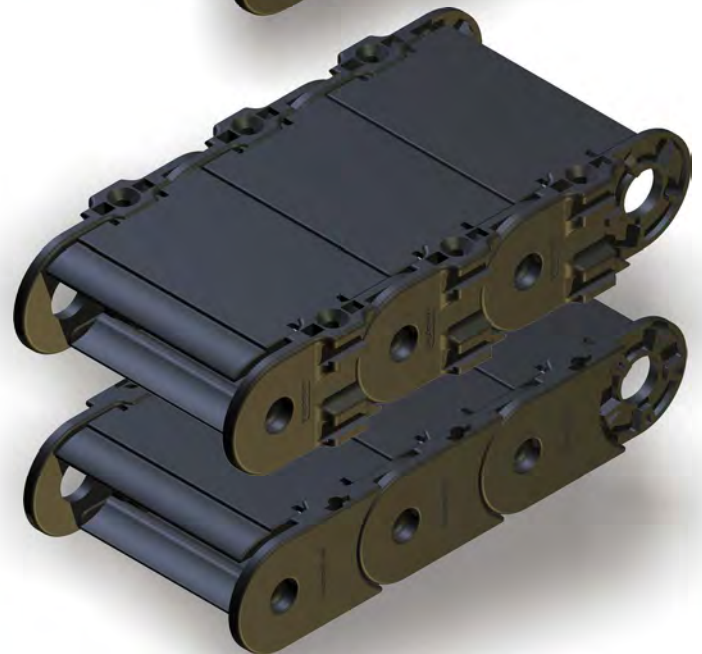
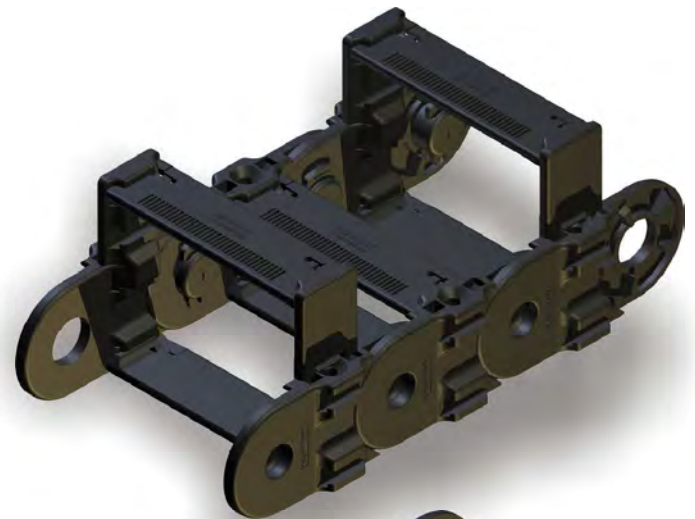

PKK SIZES

PKK120

height: 25
inner height: 16

PKK140

height: 40
inner height: 30

PKK 220

height: 50
inner height: 34

PKK 240

height: 60
inner height: 44

PKK 320

height: 75
inner height: 51

PKK 340

height: 85
inner height: 61

PKK 520

height: 104
inner height: 80

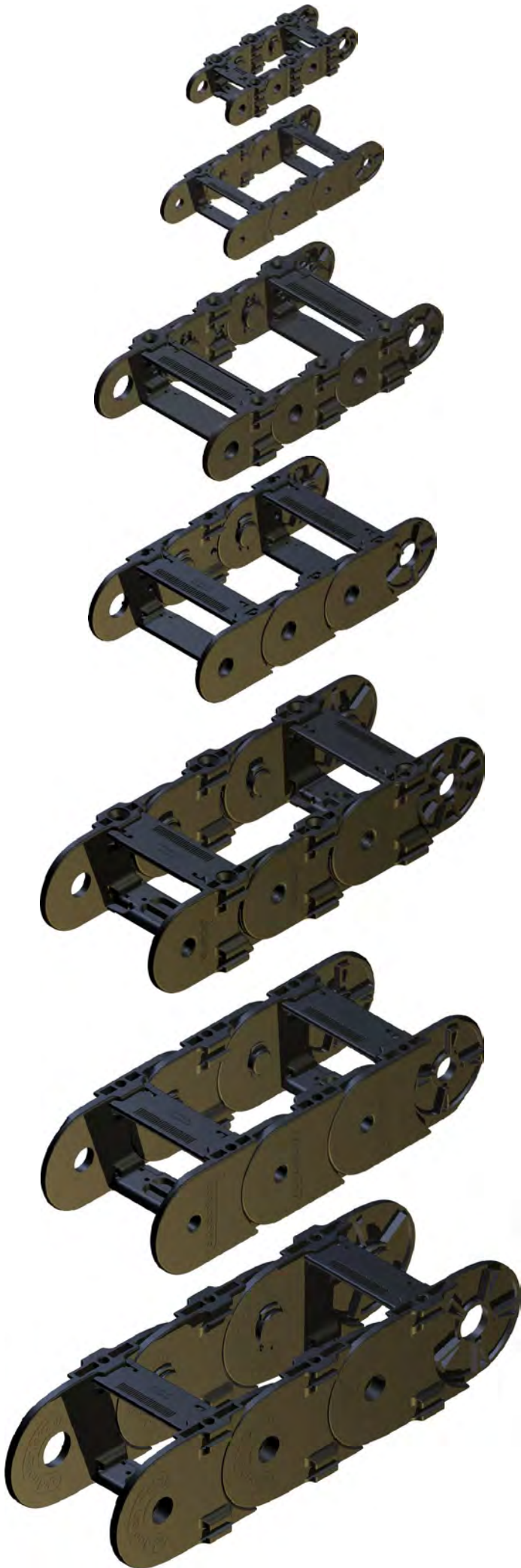

- | pos. | name |
|--------|---|
| 1 | PKK 220 link |
| 2 | PKK 210 link |
| 3 | SD / Z (universal flange connector pivot) |
| 4 | SD / B (universal flange connector drilling) |
| 5 | PKK 220 connector link short (drilling) |
| 6 | PKK 220 connector link short (pivot) |
| 8 | spreader |
| 9 | 22 stay 100 |
| 10 | 22ASI 100 (inner cover) |
| 11 | 22ASA 100 (outer cover) |
| 12 | cover holder |
| 13,13a | PZ (plastic divider) |
| 14 | PT 55 / PT 75 (telescopic horizontal divider) |
| 15 | extension stay long |
| 16 | extension stay short |
| 17 | slider R100 |
| 18 | damping element |
| 19 | band holder |
| 20 | ladder stay |
| 23 | horn stay 220 |
| 24 | PZ fork stay |
| 25 | PZ fork stay short |

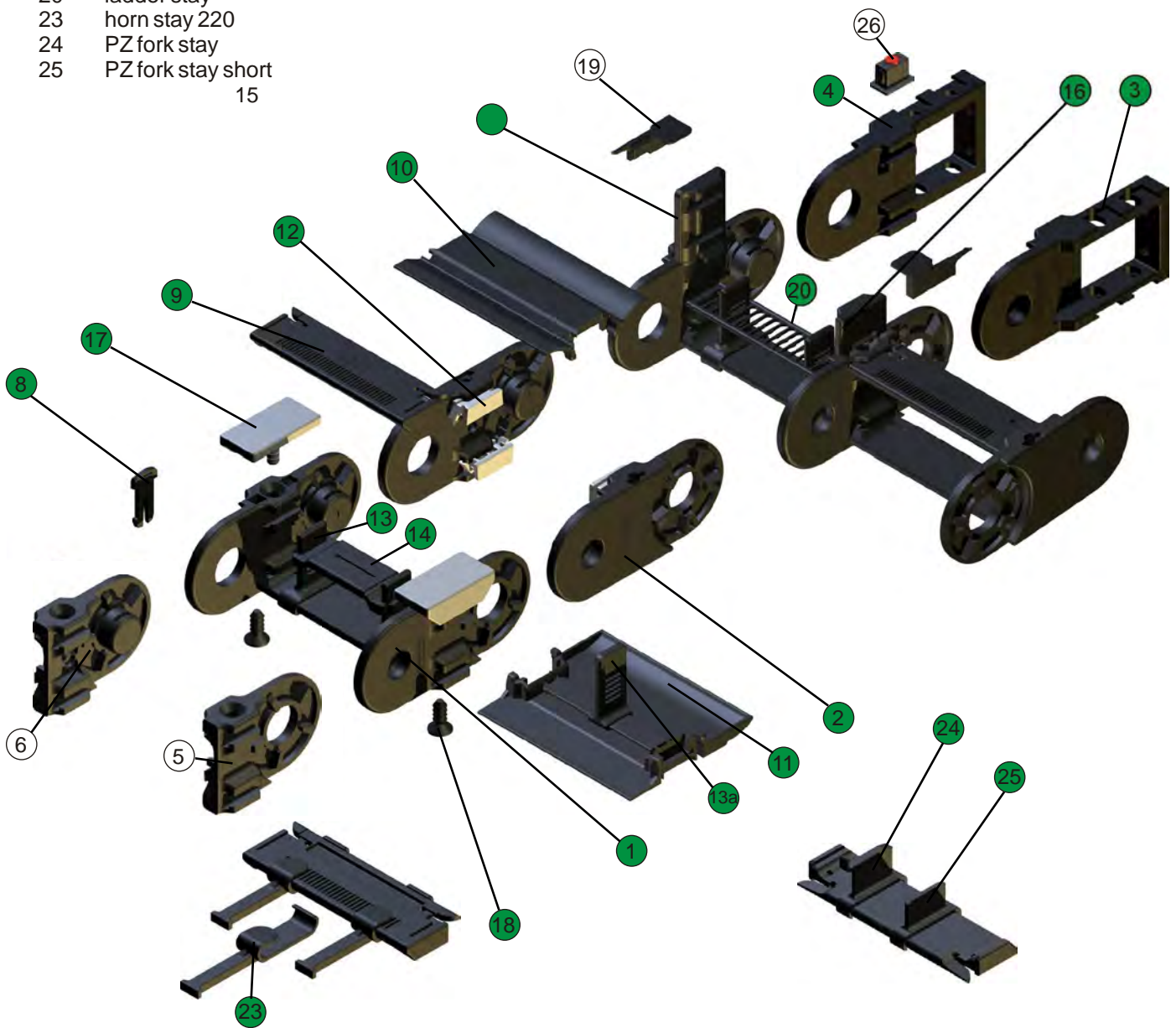

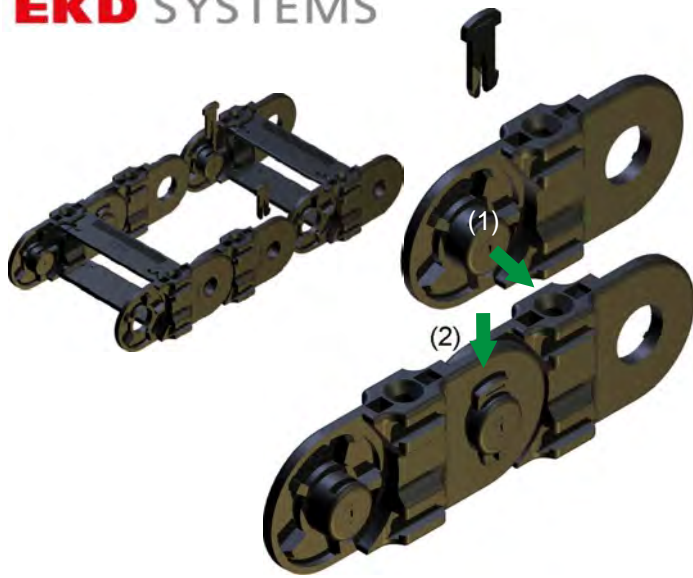

Packaging

ekd energy chains are supplied in transport friendly packaging. When removing the packaging and during removal of the energy chain or parts of it, ensure that the energy chains are free of torsion and tension, to avoid mechanical damage.

Lengthening or shortening, linkbands

Lengthening of the energy chain is done by fitting of energy chain pieces or links (1) and lock with spreader (2). To shorten the spreader is disengaged and removed, then the piece of chain removed.

Alternatively first link strands may be mounted and then stays assembled.

For the PKK the opposite link strands are rotated by 180 ° and arranged with the pivot on the inner chain.

Stay assembly

The stays with the locking tabs are put in the T-guide of the link (1) and push until it clicks into the guides (2).

The stays can be positioned initially in the T-guide and will be engaged in one swoop (plastic hammer or similar) in the final position.

Stay disassembly

The lock tongue of the stays are unlock with a screwdriver (1) and the stays pushed out with light pressure to the front of the T-slot (2). For medium and larger series (from PKK220) the stays can be unlocked with a light hit on the lock tongue (plastic hammer or similar) and then ejected.

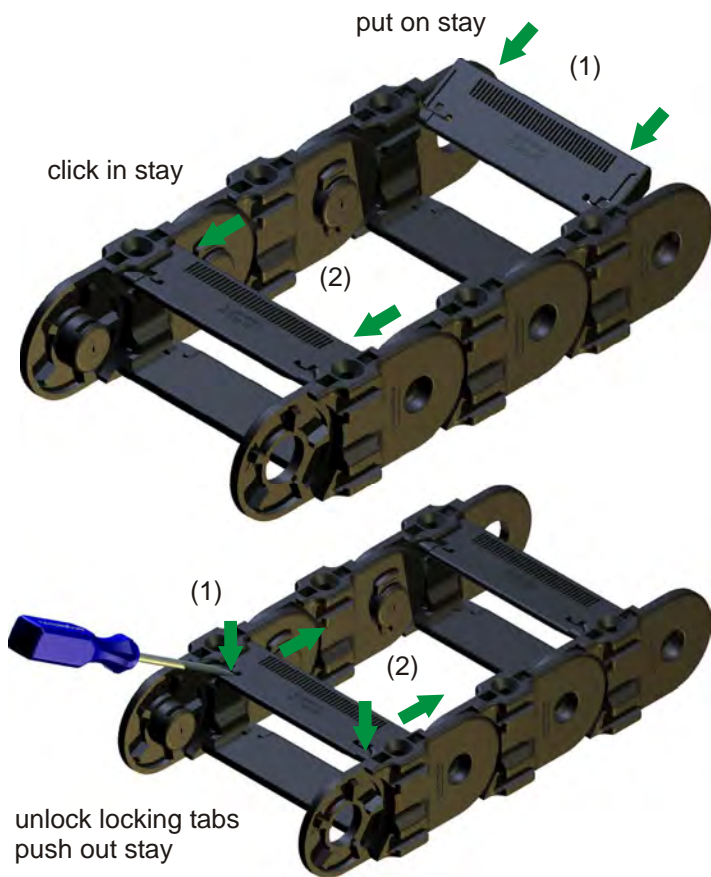

Plastic divider PZ (vertical)

The PZ will be placed in the designated position on the stay (1) and engaged (2). The PZ can be mounted fixed or movable.

The dismantling is done by unlocking (3) and removal of the PZ.

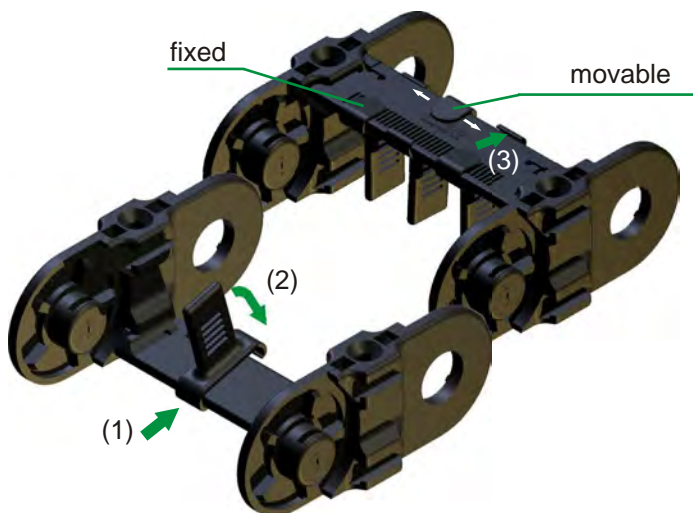

Telescopic divider and ladder divider

The telescopic horizontal divider and ladder stay horizontally pushed onto the plastic divider (PZ) and engaged in the designated height (1). The disassembly is done with a screwdriver through pull (2) and removal (3).

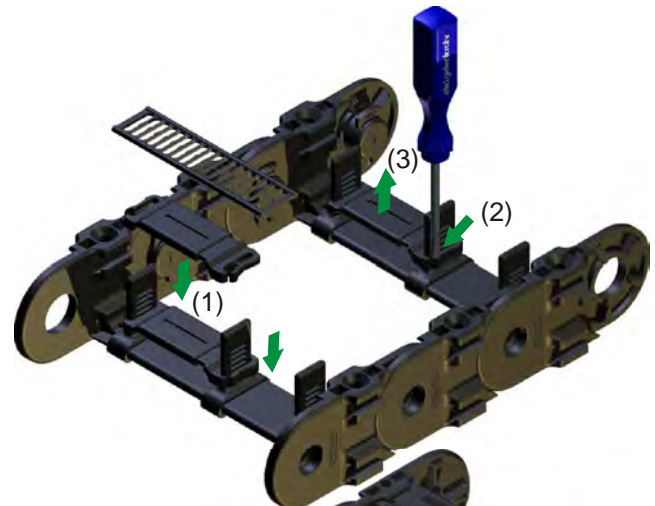

PZ fork stays

The fork stays allow in combination with an additional stay a horizontal separation and several vertical separations. Fork stays are clipped upon the stays like plastic divider PZ (p.56).

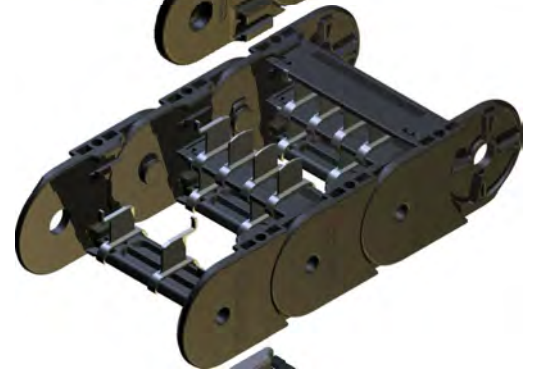

Extension stays

The extension stays are pushed onto the link guides (1) and pivoted until it clicks (1). Then the stays are pushed into the guides until it clicks (3).

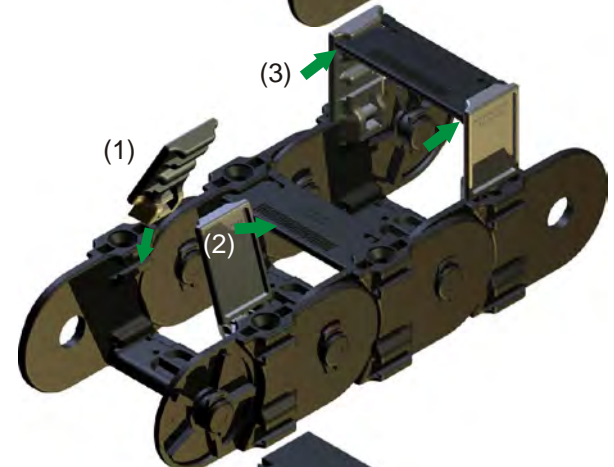

Covers

Before installing covers (ASA/ASI) first segment holder have to be pushed in the T-slot of the links (1). Then the covers can be plugged in (2). Covers and segment holder in the end position.

The covers are marked with arrows, to avoid wrong assembly direction. Covers for the outer radius are equipped with holders for divider (PZ). During assembly, ensure the correct overlap of the covers and that the covers are engaged on all four locking points.

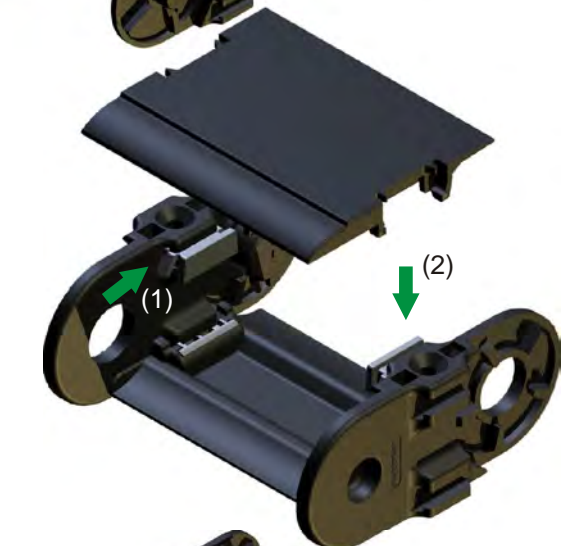

The inner radius covers (ASI) of length 200 mm of the PKK 215, 225, 245 and 300 mm of the PKK 315, 325, 345 are designed with a pivot on one side. The cover has to be pushed into the T-slot of the link on its pivot side (1) and can swing to close or open (2). For that the cover holder has to be unlocked (see disassembly).



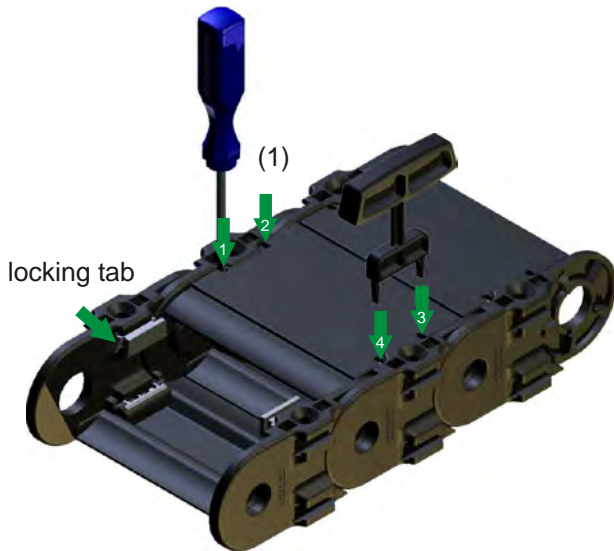

The dismantling of the covers is done by unlocking and lifting out. These are done one by one at a time with the 4 locking tongues on the segment holders using a screwdriver (1), then the cover is easy to raise.

With two release tools all four locking tongues can be done at once and the cover removed.

Attention:
The release tools can only be resolved if covers are dismantled (by lateral withdrawal)



Covers with lengths 200 mm and 300 mm of the PKK 225 and 325 are equipped with a pivot on one side. These covers opening mechanism is deactivated on one side. The covers can be swiveled.

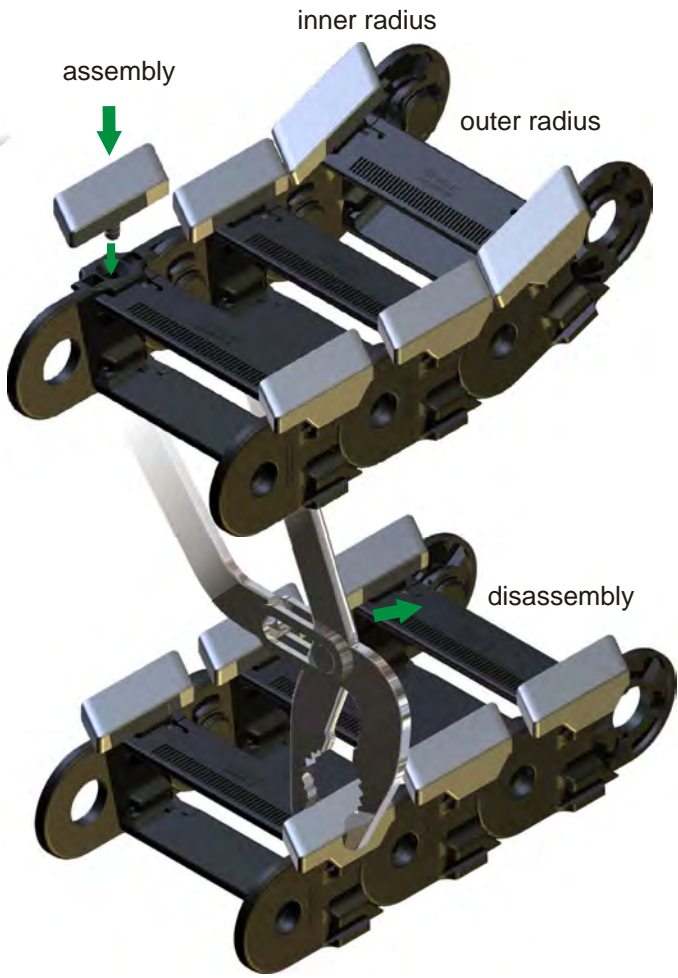

Sliders

The sliders are mounted in the inner radius of the energy chain. The minimum bend radius in each PKK size can not be fitted with sliders.

During assembly of the sliders be aware of the following:

The sliders must be conditioned (water content min. 1%, overnight storage in water at room temperature or 2 h at 80 ° C).

Heat the slider just before mounting in a water bath. Avoid impact load.

The dismantling is carried out channel lock pliers as shown and unlock slider by turning it to the outer side.

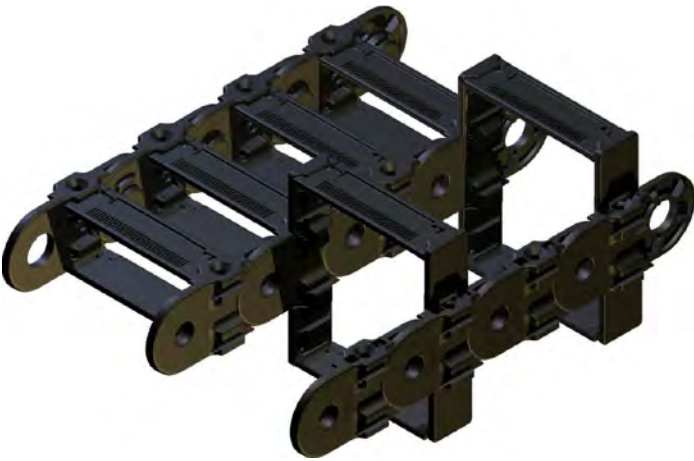

Multiband energy chains

Multiband energy chains can be created by attaching additional link strands. These are attached to existing energy chains by additional stays (see stay assembly). By combining with extension stays large hoses or other additional components may be carried.

Mounting the energy chain

All ekd plastic energy chains are equipped with the **integrated connector** (1). When using integrated strain relief, no additional components are needed. Provision for the combined strain relief, the anchor profile has to be screwed with the first link in the chain. Separate strain relief can be subsequently mounted.

Headside mounting

Optionally, the attachment can be made with flange connectors or universal connectors. The flange connectors are mounted in the T-slots of short connectors links until locking (1). The energy chains can be attached through four flange connectors (2).

The SD connectors are mounted like the links with the spreader (3) and provide universal connection options.

Strain Reliefs

With long travel distances and high speeds the lines at one end of the cable carrier, preferably on the moved driver, are attached to strain reliefs. The distance of strain relief to the bending area depends on the particulars of the line manufacturer.

Integrated strain relief

In this space-saving type strain reliefs are directly mounted on the vertical divider (PZ) of the first link of the energy chain.

The mounting direction of the PZ must be chosen so that tension directed on the chain can not unlock the divider.

In order to avoid premature line wear caused by dynamic loads a small extra chain length is recommended.

Combined strain relief

The combined strain relief combines the advantage of sufficient distance from the strain relief to the bending line areas provided by a simple and space-saving installation of the integrated strain relief.

The anchor profile is fitted to the drilling dimensions of the energy chain (integrated connectors) and attached to this. The lateral insertion and extraction of strain relief elements is possible at any time.

Separate strain relief

The separate strain relief is recommended for high dynamic loads and large line diameters. A sufficient distance from the strain relief to the chain is easy to implement.

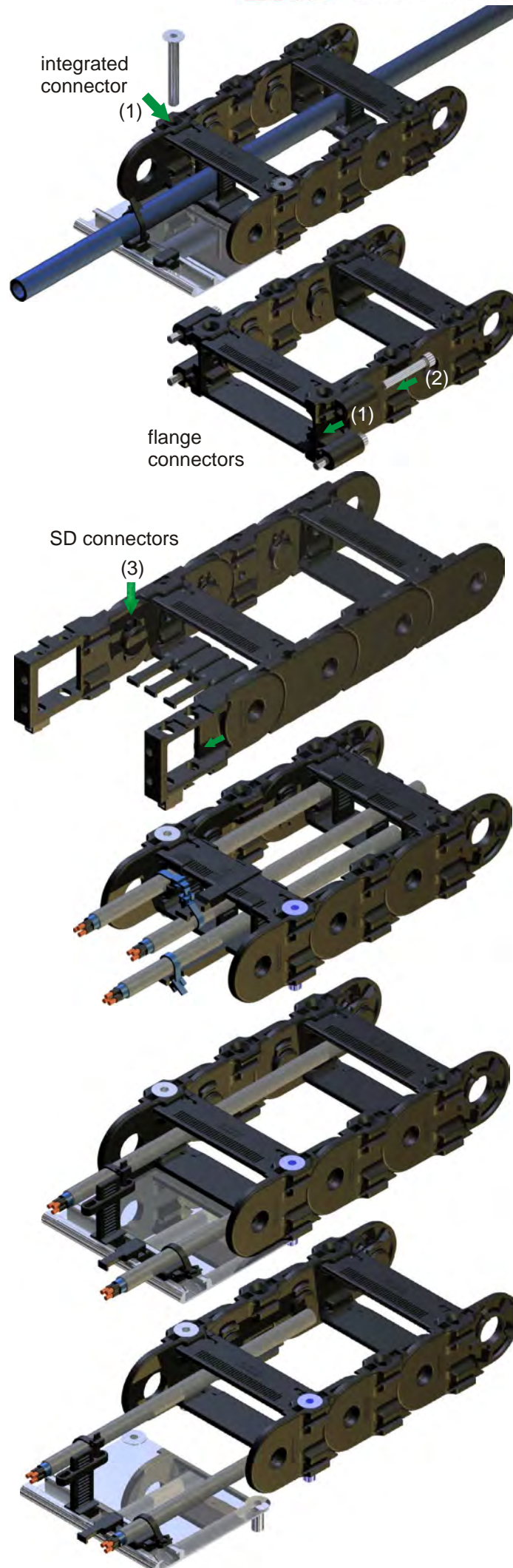

ZLP XX part no. 1163
(xx = chain width)

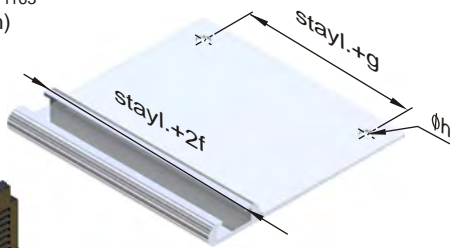

ZL 100
part no. 1612

ZL 80
part no. 1675

ZL 50
part no. 1273

$\text{Ø}7 < D < \text{Ø}35$

ZLB24
part no. 1142

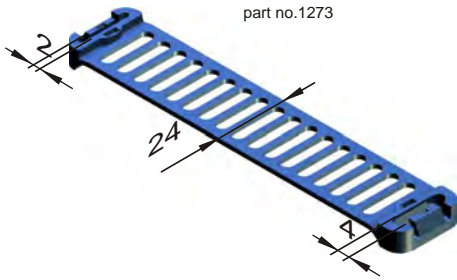

ZLS10
part no. 1160

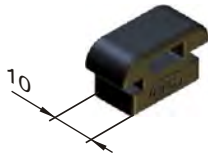

ZLA8
part no. 1159

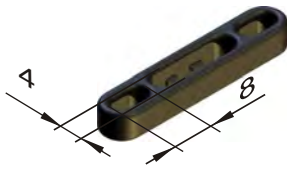

ZHS10
part no. 1407

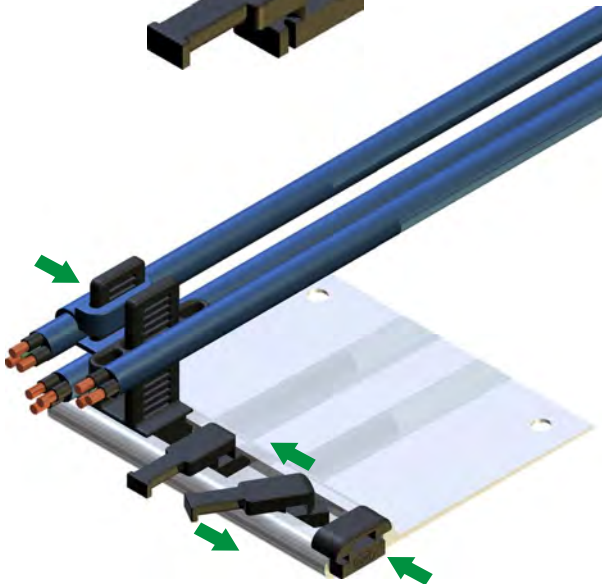
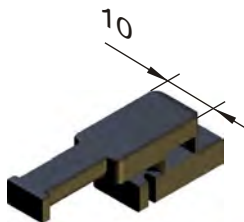

PKK ASSEMBLY

ANCHOR PROFILE ZLP

The aluminum anchor profile is used to mount various of strain relief elements. Both the distance to the energy chain as well as the positioning of the strain relief elements can be designed.

STRAIN RELIEF STAY PZL

The design of this strain relief stay is closely based on the plastic vertical divider (PZ). It is laterally inserted into the anchor profile or a c-profile and can accommodate multiple strain relief elements.

BLUE RIBBON ZLB 24

The Blue Ribbon is a special ekd developed cable tie with a 24 mm wide fixing area for cable diameters of 7 mm to 35 mm. The Blue Ribbon can be locked on the strain relief stay. The lines may be fixed single or multiple (s-shaped) with the Blue Ribbon.

PUSH ANCHOR ZLS 10

The push anchor is laterally inserted into the anchor profile or a c-profile. The lines are fixed with standard cable ties on the push anchor.

CABLE ANCHOR ZLA 8

The cable anchor is pushed onto the strain relief stay and can be fixed by the latching at different altitudes. The line is connected with commercially available cable ties on the cable anchor (single or double).

HORN STAY ZHS 10

The horn stay ZHS10 is transversely inserted into the anchor profile and locked by a 90 ° rotation. The line is fixed with cable ties at the horn.

YOKE CLAMPS

Commercially yoke clamps can be used as a separate strain relief (see below) and can be mounted with the aluminum c-profile of the SLE 520, SLE 320 in front of the energy chain connectors.

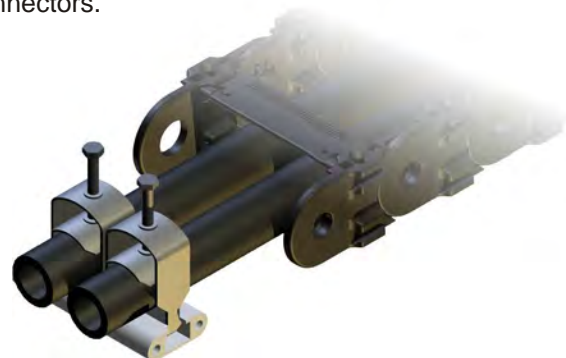

Maintenance of the energy chain

PKK energy chains are maintenance free. Like every mechanical system there will - depending on the ambient conditions - wear must be observed.

In case of this the energy chain has to be replaced.

For long travels or even in a circular motion, the energy chains are often equipped with sliding elements. These allow sliding of the upper part of the chain on a suitable surface (eg, slider-slider, slider-steel, glide bar).

The sliders show wear according to the application due to abrasion. The slider surfaces should be checked at regular intervals on their condition. With a thickness of 1-2 mm sliders have to be replaced.

PKK parts 55

special material parts like UI94 V-0, EX or other have to be named in the order



Link
m.V. with pretension
o.V. without pretension



PKK	R	40	50	60	75	PKK	R	40	50	60	75							
110,111 113 115	m.V.	1598	1599	1600	1601	120, 121 123 125	m.V.	0380	0379	0378	0377							
	o.V.	1605	1604	1603	1602		o.V.	1717	1716	1715	1714							
	R	50	60	80	100													
140, 141 143	m.V.	2174	2175	2176	2177													
	o.V.	2181	2182	2183	2184													
	R	65	75	100	125		R	75	100	125	150	200	250	300				
210, 211 213 215	m.V.	1454	1299	1300	1635	1301	1302	1571	1303	220, 221 223 225 228	m.V.	0394	1295	2225	1296	1297	1596	1298
	o.V.	2221	2215	2216	2217	2218	2219	2224	2220		o.V.	2192	2193	2194	2195	2196	2197	2198
	R	75	100	120	150	200	250	300										
240, 241 243 245	m.V.	1455	1456	2405	1457	1458	1459	1460										
	o.V.	2209	2210	2406	2211	2212	2213	2214										
	R	100	120	130	150	200	250	300	400		R	100	150	200	250	300	400	
310, 311 313 315	m.V.	1309	2115	1310	1311	1312	1926	1313	1314	320, 321 323 325 328	m.V.	0421	1305	1306	1570	1307	1308	
	o.V.	2200	2116	2201	2204	2205	2206	2207	2208		o.V.	2199	0420	0419	1569	0418	0417	
	R	100	150	200	250	300	400											
340, 341 343 345	m.V.	1544	1545	1546	1763	1547	1548											
	o.V.	2226	1543	1542	2227	1541	1540											
	R	150	200	250	300	400	500			R	150	200	250	300	400	500		
510, 511 513 515	m.V.	1766	1767	1768	1769	1770	1771			520, 521 523 525 528	m.V.	1094	1095	1437	1096	1097	1098	
	o.V.	2235	2236	2237	2240	2238	2239				o.V.	2230	2231	2232	2081	2233	2234	

PKK ELTOLA	R	75	100	125	150	200	250	300	400
210					2089			2090	
220					2091	2092	2093	2094	2095
240					2098	2099		2100	2101
310								2102	2103
320									2086
340								2088	2087

PKK 210 / 0 5 Anschl. 2045
PKK 210 / 0 2 Anschl. 2046



PKK 30 50 60 70 80 90 100 110 120 130 150 170 180 200 220 230 250 270 300 330 400

110	0373	0374	0375	0372	0371	0370	0369	1815	1864	-	-	-	-	-	-	-	-	-	-	-	
111	0373	0374	0375	0372	0371	0370	0369	1815	1864	-	-	-	-	-	-	-	-	-	-	-	
113	0373	0374	0375	0372	0371	0370	0369	1815	1864	-	-	-	-	-	-	-	-	-	-	-	
115	-	-	-	-	-	-	-	-	-	-	-	-	-	-	-	-	-	-	-	-	
120	0373	0374	0375	0372	0371	0370	0369	1815	1864	-	-	-	-	-	-	-	-	-	-	-	
121	0373	0374	0375	0372	0371	0370	0369	1815	1864	-	-	-	-	-	-	-	-	-	-	-	
123	0373	0374	0375	0372	0371	0370	0369	1815	1864	-	-	-	-	-	-	-	-	-	-	-	
125	-	-	-	-	-	-	-	-	-	-	-	-	-	-	-	-	-	-	-	-	
140	0373	0374	0375	0372	0371	0370	0369	1815	1864	-	-	-	-	-	-	-	-	-	-	-	
141	0373	0374	0375	0372	0371	0370	0369	1815	1864	-	-	-	-	-	-	-	-	-	-	-	
143	0373	0374	0375	0372	0371	0370	0369	1815	1864	-	-	-	-	-	-	-	-	-	-	-	
210	-	0390	0389	0388	0387	0386	0385	1517	0384	1436	0383	0382	-	0381	1887	-	-	-	-	-	
211	-	0390	0389	0388	0387	0386	0385	1517	0384	1436	0383	0382	-	0381	1887	-	-	-	-	-	
213	-	0390	0389	0388	0387	0386	0385	1517	0384	1436	0383	0382	-	0381	1887	-	-	-	-	-	
215	-	-	-	-	-	-	-	-	-	-	-	-	-	-	-	-	-	-	-	-	
220	-	0390	0389	0388	0387	0386	0385	1517	0384	1436	0383	0382	-	0381	1887	-	-	-	-	-	
221	-	0390	0389	0388	0387	0386	0385	1517	0384	1436	0383	0382	-	0381	1887	-	-	-	-	-	
223	-	0390	0389	0388	0387	0386	0385	1517	0384	1436	0383	0382	-	0381	1887	-	-	-	-	-	
225	-	-	-	-	-	-	-	-	-	-	-	-	-	-	-	-	-	-	-	-	
228	-	0390	0389	0388	0387	0386	0385	1517	0384	1436	0383	0382	-	0381	1887	-	-	-	-	-	
240	-	0390	0389	0388	0387	0386	0385	1517	0384	1436	0383	0382	-	0381	1887	-	-	-	-	-	
241	-	0390	0389	0388	0387	0386	0385	1517	0384	1436	0383	0382	-	0381	1887	-	-	-	-	-	
243	-	0390	0389	0388	0387	0386	0385	1517	0384	1436	0383	0382	-	0381	1887	-	-	-	-	-	
245	-	-	-	-	-	-	-	-	-	-	-	-	-	-	-	-	-	-	-	-	
310	-	0416	1564	1565	1164	1566	0411	-	1009	1567	0410	1392	1888	0409	-	1889	0408	1929	0407	1931	2001
311	-	0416	1564	1565	1164	1566	0411	-	1009	1567	0410	1392	1888	0409	-	1889	0408	1929	0407	1931	2001
313	-	0416	1564	1565	1164	1566	0411	-	1009	1567	0410	1392	1888	0409	-	1889	0408	1929	0407	1931	2001
315	-	-	-	-	-	-	-	-	-	-	-	-	-	-	-	-	-	-	-	-	-
320	-	0416	1564	1565	1164	1566	0411	-	1009	1567	0410	1392	1888	0409	-	1889	0408	1929	0407	1931	2001
321	-	0416	1564	1565	1164	1566	0411	-	1009	1567	0410	1392	1888	0409	-	1889	0408	1929	0407	1931	2001
323	-	0416	1564	1565	1164	1566	0411	-	1009	1567	0410	1392	1888	0409	-	1889	0408	1929	0407	1931	2001
325	-	-	-	-	-	-	-	-	-	-	-	-	-	-	-	-	-	-	-	-	-
328	-	0416	1564	1565	1164	1566	0411	-	1009	1567	0410	1392	1888	0409	-	1889	0408	1929	0407	1931	2001
340	-	0416	1564	1565	1164	1566	0411	-	1009	1567	0410	1392	1888	0409	-	1889	0408	1929	0407	1931	2001
341	-	0416	1564	1565	1164	1566	0411	-	1009	1567	0410	1392	1888	0409	-	1889	0408	1929	0407	1931	2001
343	-	0416	1564	1565	1164	1566	0411	-	1009	1567	0410	1392	1888	0409	-	1889	0408	1929	0407	1931	2001
345	-	-	-	-	-	-	-	-	-	-	-	-	-	-	-	-	-	-	-	-	-
510	-	0416	1564	1565	1164	1566	0411	-	1009	1567	0410	1392	1888	0409	-	1889	0408	1929	0407	1931	2001
511	-	0416	1564	1565	1164	1566	0411	-	1009	1567	0410	1392	1888	0409	-	1889	0408	1929	0407	1931	2001
513	-	0416	1564	1565	1164	1566	0411	-	1009	1567	0410	1392	1888	0409	-	1889	0408	1929	0407	1931	2001
515	-	-	-	-	-	-	-	-	-	-	-	-	-	-	-	-	-	-	-	-	-
520	-	0416	1564	1565	1164	1566	0411	-	1009	1567	0410	1392	1888	0409	-	1889	0408	1929	0407	1931	2001
521	-	0416	1564	1565	1164	1566	0411	-	1009	1567	0410	1392	1888	0409	-	1889	0408	1929	0407	1931	2001
523	-	0416	1564	1565	1164	1566	0411	-	1009	1567	0410	1392	1888	0409	-	1889	0408	1929	0407	1931	2001
525	-	-	-	-	-	-	-	-	-	-	-	-	-	-	-	-	-	-	-	-	-
528	-	0416	1564	1565	1164	1566	0411	-	1009	1567	0410	1392	1888	0409	-	1889	0408	1929	0407	1931	2001

PKK parts 55

special material parts like UI94 V-0, EX or other have to be named in the order



PKK	ASA	ASI	ASA	ASI	ASA	ASI	ASA	ASI	ASA	ASI	SH	SR	ASK	ASL	GL
	50	50	100	100	150	150	200	200	300	300					
110	-	-	-	-	-	-	-	-	-	-	-	0367	-	-	-
111	-	-	-	-	-	-	-	-	-	-	-	0367	-	-	-
113	-	-	-	-	-	-	-	-	-	-	-	0367	1984	-	-
115	0364	0362	0363	0361	-	-	-	-	-	-	0360	0367	-	-	-
120	-	-	-	-	-	-	-	-	-	-	-	0367	-	-	-
121	-	-	-	-	-	-	-	-	-	-	-	0367	-	-	-
123	-	-	-	-	-	-	-	-	-	-	-	0367	1984	-	-
125	0364	0362	0363	0361	-	-	-	-	-	-	0360	0367	-	-	-
140	-	-	-	-	-	-	-	-	-	-	-	0367	-	-	-
141	-	-	-	-	-	-	-	-	-	-	-	0367	-	-	-
143	-	-	-	-	-	-	-	-	-	-	-	0367	-	-	-
210	-	-	-	-	-	-	-	-	-	-	-	0404	-	-	-
211	-	-	-	-	-	-	-	-	-	-	-	0404	-	-	-
213	-	-	-	-	-	-	-	-	-	-	-	0404	1893	1892	-
215	0401	0399	0400	0398	0487	0485	0888	0887	-	-	0397	0404	-	-	-
220	-	-	-	-	-	-	-	-	-	-	-	0404	-	-	-
221	-	-	-	-	-	-	-	-	-	-	-	0404	-	-	-
223	-	-	-	-	-	-	-	-	-	-	-	0404	1893	1892	-
225	0401	0399	0400	0398	0487	0485	0888	0887	-	-	0397	0404	-	-	1740
228	-	-	-	-	-	-	-	-	-	-	-	0404	-	-	402,1742
240	-	-	-	-	-	-	-	-	-	-	-	0404	-	-	-
241	-	-	-	-	-	-	-	-	-	-	-	0404	-	-	Slider selection: See page 50
243	-	-	-	-	-	-	-	-	-	-	-	0404	1893	1892	-
245	0401	0399	0400	0398	0487	0485	0888	0887	-	-	0397	0404	-	-	-
310	-	-	-	-	-	-	-	-	-	-	-	0434	-	-	-
311	-	-	-	-	-	-	-	-	-	-	-	0434	-	-	-
313	-	-	-	-	-	-	-	-	-	-	-	0434	1885	1886	-
315	-	-	0428	0426	0427	0425	0491	0489	0492	0490	0424	0434	-	-	-
320	-	-	-	-	-	-	-	-	-	-	-	0434	-	-	-
321	-	-	-	-	-	-	-	-	-	-	-	0434	-	-	-
323	-	-	-	-	-	-	-	-	-	-	-	0434	1885	1886	-
325	-	-	0428	0426	0427	0425	0491	0489	0492	0490	0424	0434	-	-	1741
328	-	-	-	-	-	-	-	-	-	-	-	0434	-	-	0432,1632
340	-	-	-	-	-	-	-	-	-	-	-	0434	-	-	-
341	-	-	-	-	-	-	-	-	-	-	-	0434	-	-	-
343	-	-	-	-	-	-	-	-	-	-	-	0434	1885	1886	-
345	-	-	0428	0426	0427	0425	0491	0489	0492	0490	0424	0434	-	-	-
510	-	-	-	-	-	-	-	-	-	-	-	1474	-	-	-
511	-	-	-	-	-	-	-	-	-	-	-	1474	-	-	-
513	-	-	-	-	-	-	-	-	-	-	-	1474	1885	1886	-
515	-	-	-	-	1399	1400	1401	1402	-	-	1478	1474	-	-	-
520	-	-	-	-	-	-	-	-	-	-	-	1474	-	-	-
521	-	-	-	-	-	-	-	-	-	-	-	1474	-	-	-
523	-	-	-	-	-	-	-	-	-	-	-	1474	1885	1886	-
525	-	-	-	-	1399	1400	1401	1402	-	-	1478	1474	-	-	-
528	-	-	-	-	1399	1400	1401	1402	-	-	1478	1474	-	-	1800, 1801

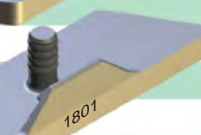
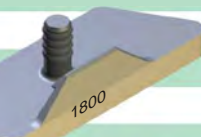
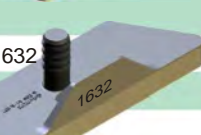
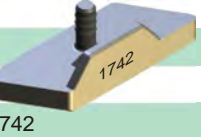
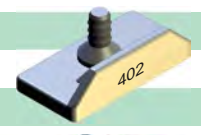

PKK PART NUMBERS



PKK PZ GS GSK PTF PT55 PT75 TL35 LS HS FK SK SD B / Z
 Hülse Stecker 220/320

110	0368			-	-	-			-	2442	-	-	-	-		
111	0368			-	-	-			-	2442	-	-	-	-		
113	0368			-	-	-			-	2442	-	-	-	-		
115	0359			-	-	-			-	-	-	-	-	-		
120	0368			-	-	-			-	2442	-	-	-	-		
121	0368			-	-	-			-	2442	-	-	-	-		
123	0368			-	-	-			-	2442	-	-	-	-		
125	0359			-	-	-			-	-	-	-	-	-		
140	2187			-	-	-			-	2442	-	-	2459	2458		
141	2187			-	-	-			-	2442	-	-	2459	2458		
143	2187			-	-	-			-	2442	-	-	2459	2458		
210	0405				1927	0879	0880			1665	1847	1269	-	2111	2110	
211	0405				1927	0879	0880			1665	1847	1269	-	2111	2110	
213	0405				1927	0879	0880			1665	1847	1269	-	2111	2110	
215	0396				1927	0879	0880			1665	-	1269	-	2111	2110	
220	0405				1927	0879	0880			1665	1847	-	1366	2111	2110	
221	0405				1927	0879	0880			1665	1847	-	1366	2111	2110	
223	0405				1927	0879	0880			1665	1847	-	1366	2111	2110	
225	0396				1927	0879	0880			1665	-	-	1366	2111	2110	
228	0405				1927	0879	0880			1665	1847	-	1366	2111	2110	
240	1461	1976	1979		1927	0879	0880			1665	1847	1269	-	-	-	
241	1461	1976	1979		1927	0879	0880			1665	1847	1269	-	-	-	
243	1461				1927	0879	0880			1665	1847	1269	-	-	-	
245	1463				1927	0879	0880			1665	-	1269	-	-	-	
310	0423				1927	0879	0880			1665	1848	1317	-	2171 ¹⁾	2170 ¹⁾	
311	0423				1927	0879	0880			1665	1848	1317	-	2171	2170	
313	0423				1927	0879	0880			1665	1848	1317	-	2171	2170	
315	0422				1927	0879	0880			1665	-	1317	-	2171	2170	
320	0423				1927	0879	0880			1665	1848	-	1365	2171	2170	
321	0423				1927	0879	0880			1665	1848	-	1365	2171	2170	
323	0423				1927	0879	0880			1665	1848	-	1365	2171	2170	
325	0422				1927	0879	0880			1665	-	-	1365	2171	2170	
328	0423				1927	0879	0880			1665	1848	-	1365	2171	2170	
340	1549	2012	2013		1927	0879	0880			1665	1848	1317	-	2339	2338	
341	1549	2012	2013		1927	0879	0880			1665	1848	1317	-	2339	2338	
343	0423				1927	0879	0880			1665	1848	-	-	2339	2338	
345	1654				1927	0879	0880			1665	-	1317	-	2339	2338	
510	1067				1927	0879	0880			1665	1848	1317	-	-	-	
511	1067				1927	0879	0880			1665	1848	1317	-	-	-	
513	1067				1927	0879	0880			1665	1848	1317	-	-	-	
515	1477				1927	0879	0880			1665	-	1317	-	-	-	
520	1067				1927	0879	0880			1665	1848	1317	-	-	-	
521	1067				1927	0879	0880			1665	1848	1317	-	-	-	
523	1067				1927	0879	0880			1665	1848	1317	-	-	-	
525	1477				1927	0879	0880			1665	-	1317	-	-	-	
528	1067				1927	0879	0880			1665	1848	1317	-	-	-	

PLE

- PLE applications 67
- PLE dimensions 68
- PLE types 69
- PLE sizes 71
- PLE parts 72
- PLE assembly 73
- PLE part numbers 76



closed + open

PLE CHARACTERISTICS

The PLE with aluminum stays is available as **PLE** with plastic inserts or plastic slot profile, as **PLS** with foam slot profile or as **PLP** with plastic divider PZ.

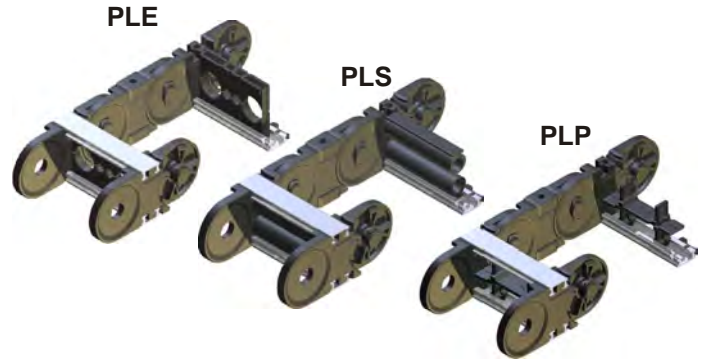

- positive stay locking
- both inside and outside radius can be opened
- simple to shorten or lengthen
- stepless stay length up to 1000 mm

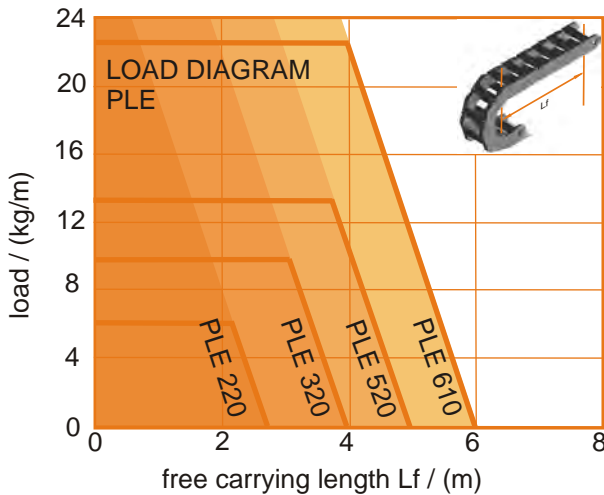

All ekd plastic energy chains are equipped with the **integrated connector**. Additional components for mounting the energy chain are not required.

Travel

The maximum travel is determined by the arrangement and the additional weight (line weight). At normal arrangement the maximum travel is twice the free carrying length. Support rollers or similar constructive steps can increase this value.

In gliding arrangements travel distances up to 100 meters are possible.

Longer travel distances need further constructive steps, like SYSTEM MARATHON, which exceeds the travel distance nearly without limits.

Travel speed

There are no limits for the travel speed in general. But in gliding applications specific influences have to be taken into account.

Acceleration

In principle there are no restrictions for the acceleration. Limits can only be achieved at high tension forces caused by high additional weights.

Temperature

The operating temperature is inbetween -20 °C and 100 °C.

Special versions

- | | |
|----------|------------------------|
| ALLROUND | ... all movements |
| ATEX | ... EX-protection |
| ESD | ... antistatic |
| V-0 | ... self extinguishing |

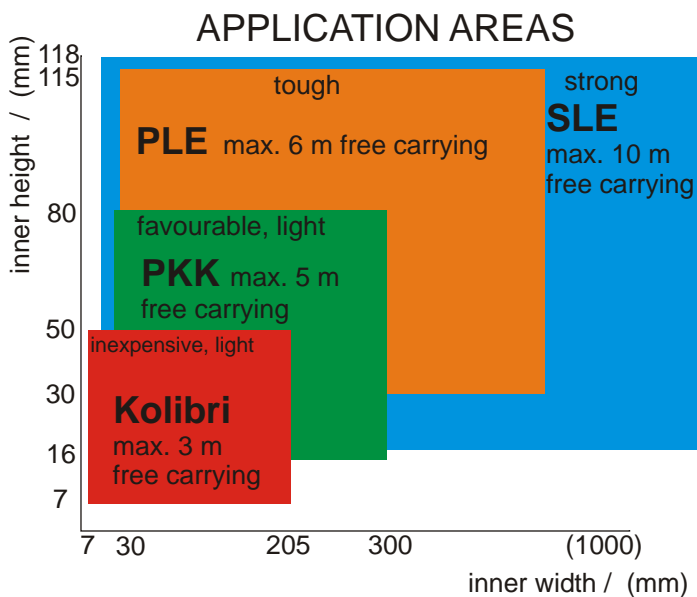

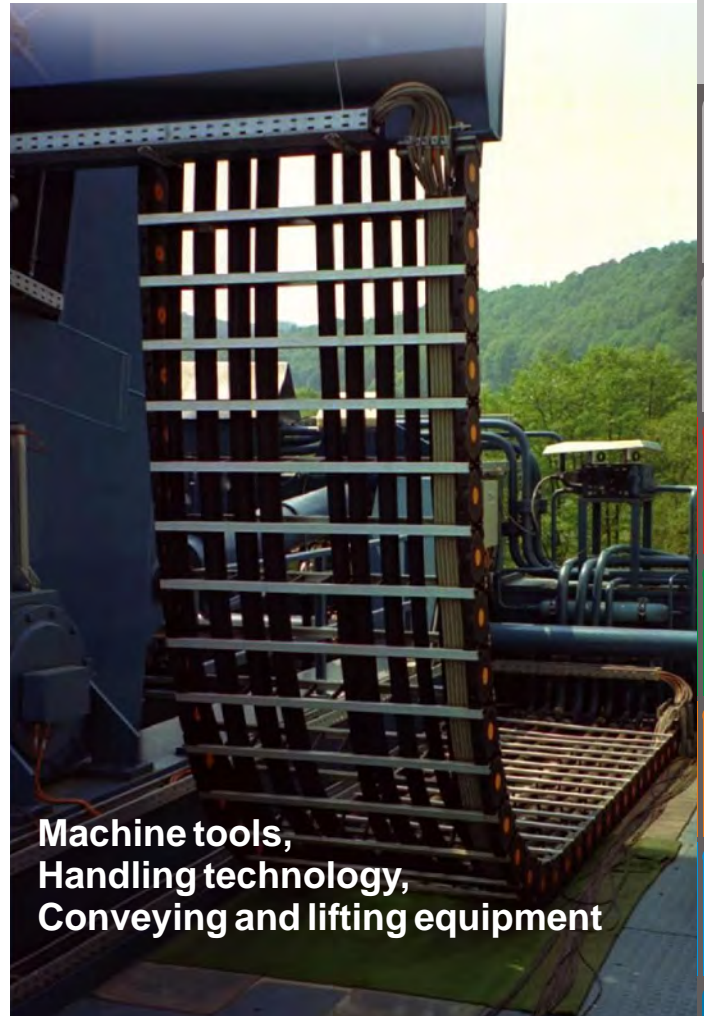

**Machine tools,
Handling technology,
Conveying and lifting equipment**



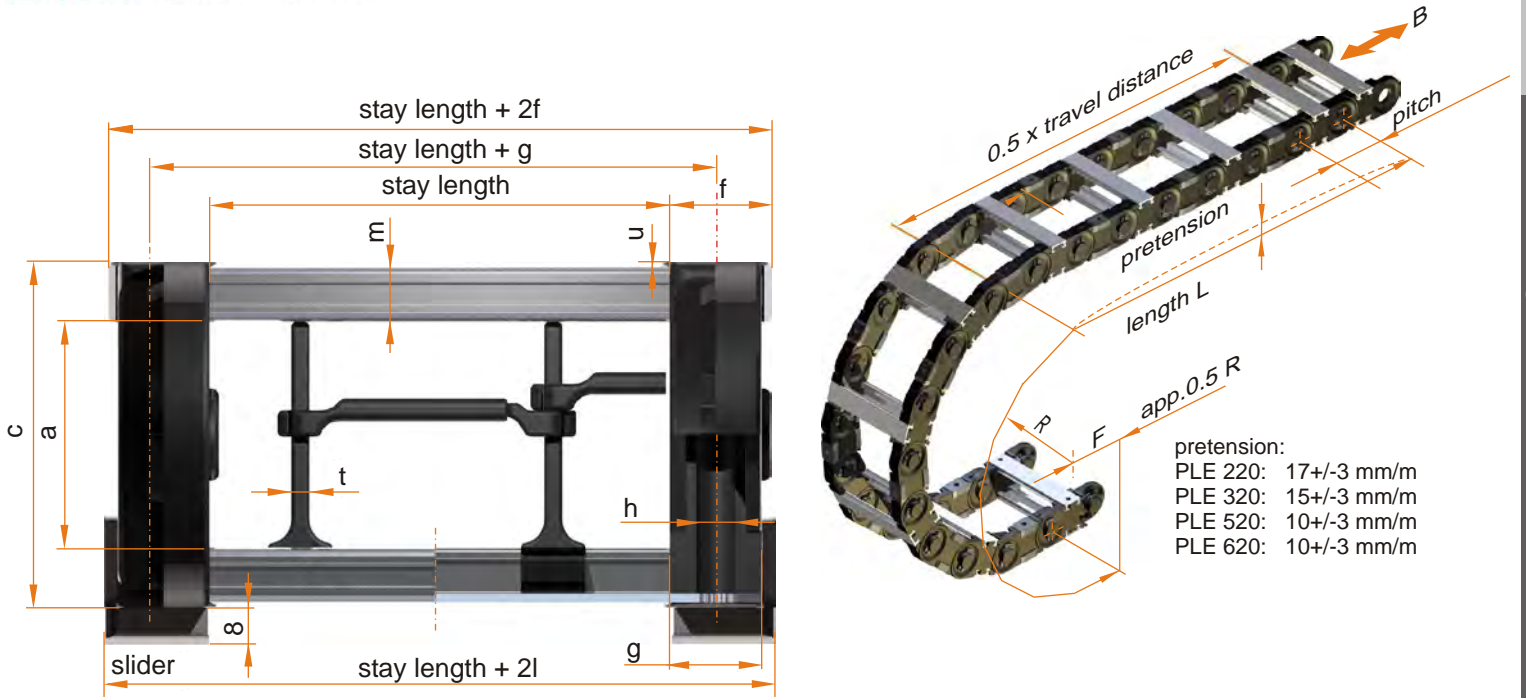

The usable interior width is stay length - 2 mm

PLE	bending radius R [mm]	pitch	a	c	f	g	h	l ¹⁾	m	t	u	weight [kg/m] ³⁾
220, 221	75 100 150 200 300	75	31	50	18	16	Ø6	-	9	4	1	1.9
320, 321, 325, 328 ²⁾	150 200 250 300 400	100	49	75	22	20	Ø8	23	12	4	1	3.4 (4.4)
520, 521, 525, 528 ²⁾	200 250 300 400 500	125	68	100	26	24	Ø8	27	15	4	1	4.8 (5.9)
541, 548 ²⁾	200 250 300 400 500	125	80	100	26	24	Ø8	27	9	4	1	4.60
610, 611, 615	219 250 315 410 500 700	150	120 ⁴⁾	140	20	20	Ø10	-	9	8	1	6,5 (7,0)
613	230 300 400 500 700	150	Inner height available									6,80

1) stay length + 2l is the outside width, including sliders 2) PLE 328 from R200, PLE 528, 548 from R250
 3) weight with stay length 100, values in brackets for closed version 4) 615 a = 110

PLE	minimum stay length [mm]	maximum stay length [mm]	PLE inserts Ø [mm]														
220, 221	50	800	10	15	20	25	30										
320, 321, 325, 328	60	900	10	15	20	25	30	35	40	45	50						
520, 521, 525, 528	70	1000	10	15	20	25	30	35	40	45	50	55	60	65	70		
541, 548	70	900															
610, 611, 615	90	1000															

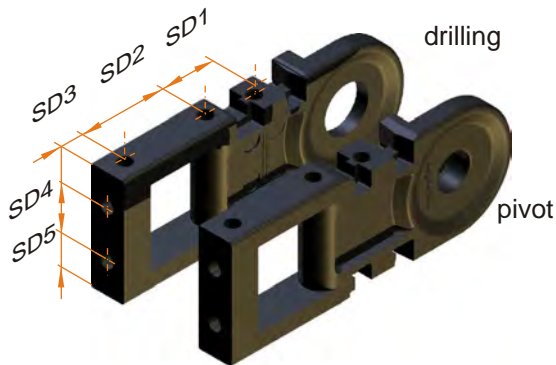

The stay lengths are offered in steps of 1 mm.

PLE SD- connector	SD1	SD2	SD3	SD4	SD5
220, 221, 225	22,5	37,5	8,5	22	7,5
320, 321, 325, 328	35	45	8,5	45	15
520, 521, 525, 528	35	45	8,5	66	17

order example: travel distance 3 m, bending radius 200 mm, cable: 1x15 mm, 8x8 mm, 3x12 mm, 2x22 mm, chain arrangement is hanging

PLE 320 / 200	x	2300	/ 200	/ SD 32, SD 32 /	h	/ 5 PZ, 1 Pt55
type / radius	x	length	/ stay length /	connectors /	arrangement /	stay distribution

PLE energy chains are distinguished from standard plastic chains by their extreme stability and the rigid, continuously adjustable aluminum profile. Stay lengths up to 1000 mm can be accommodated.

The allocation of the interior offers variable opportunities and guarantees optimum line protection even at high acceleration and travel speed.

The **PLE** (PLE with plastic inserts or plastic insert-profile) ensures a perfect guide at high speeds. Errors during installation of the cables are nearly impossible, with this variation, the hole design of the stays meet exactly the requirements of the lines. Plastic inserts are available in 5 mm steps. The plastic insert-profile can be ordered according to drawing.

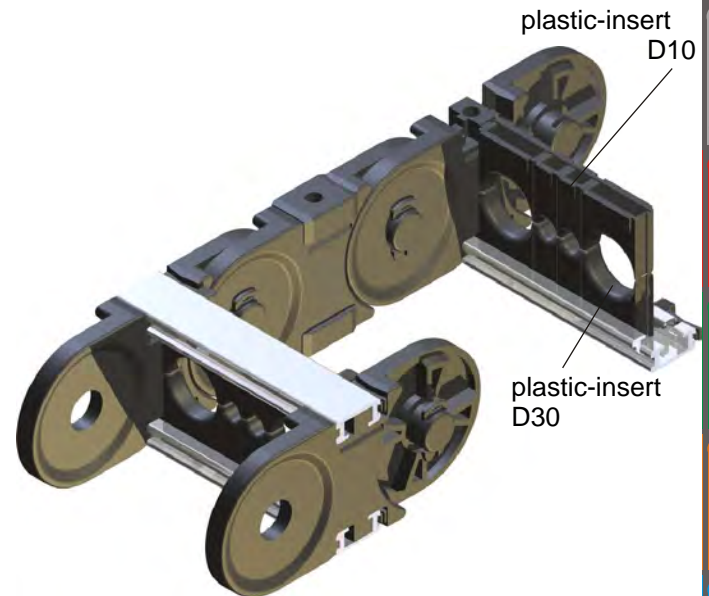

In case of limited installation space, the **PLS** (PLE with foam insert-profile) are used. Again, the optimal guiding of the lines at high speeds and acceleration is ensured. All lines are in the neutral axis (middle of chain height).

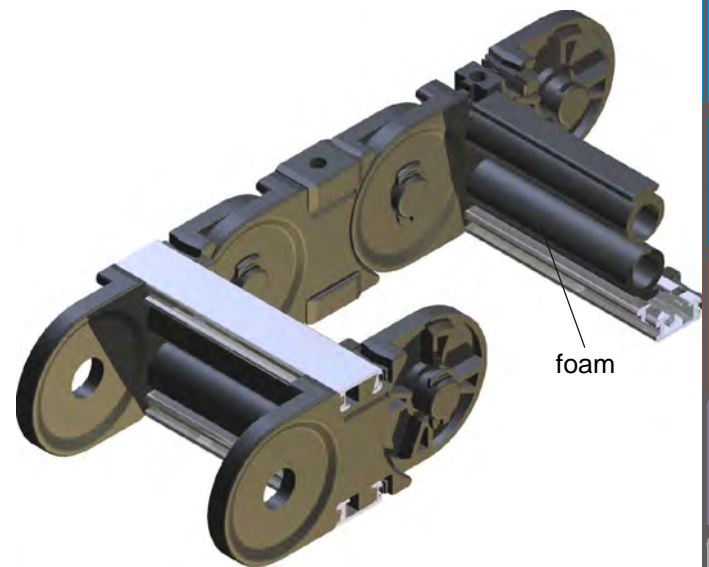

For space reasons the **PLP** (PLE with plastic dividers) may be chosen. This inexpensive design allows secure guiding of large amounts of cable. The highly variable stay distribution opportunities through the small steps (3mm) in height and the infinitely adjustable plastic telescopic dividers (PT) allow maximum space for all needs, even when changes in cable diameters are required.

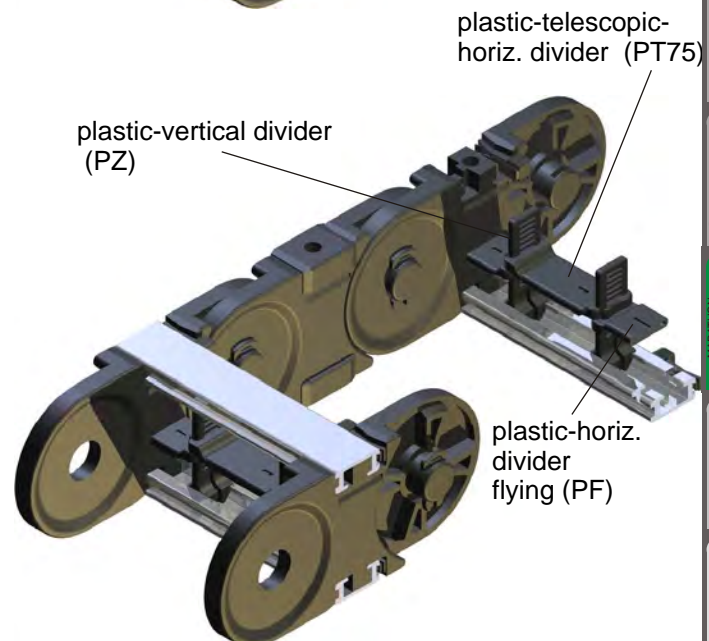

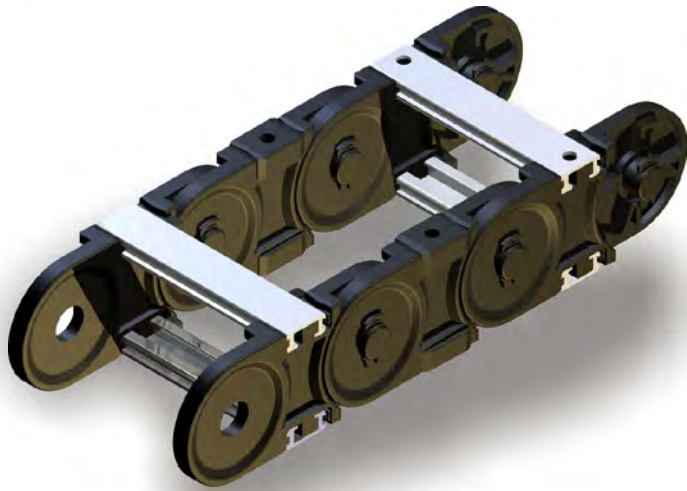

PLE 220, 320, 520, 610

The standard type is build with stays in every second chain link. The **integrated connector** makes every link in the chain when needed to a connector (*not 620*) and therefore the separate ordering and storage of end connector brackets is not necessary.

order example:

PLE 220	/ 100	x 3525	/ 100
type	radius	length	stay length

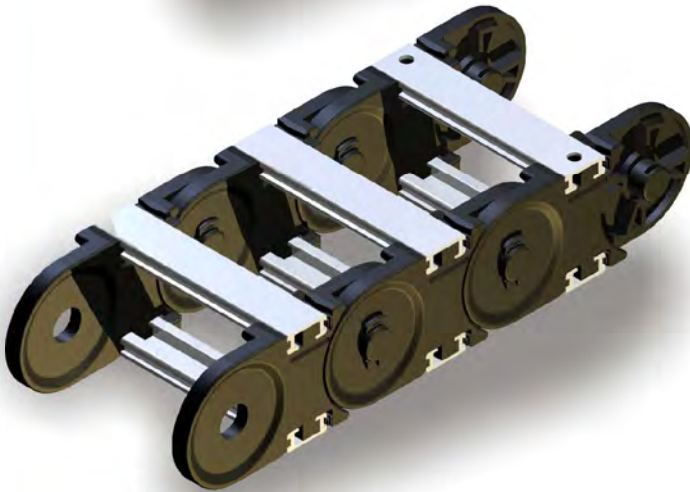

PLE 221, 321, 521, 541, 611

These designs are made with stays in each link. This increases the lateral stability and improves the guiding particularly of smaller diameter lines.

order example:

PLE 221	/ 100	x 3525	/ 100
type	radius	length	stay length

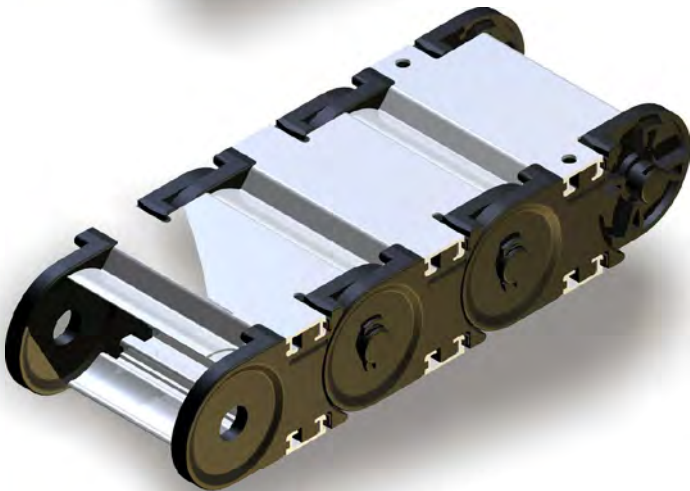

PLE 325, 525, 615

The closed types with aluminum covers may also replace the standard version stay. The covers can be opened in the inner or outer radius.

order example:

PLE 325	/ 300	x 3500	/ 100
type	radius	length	stay length

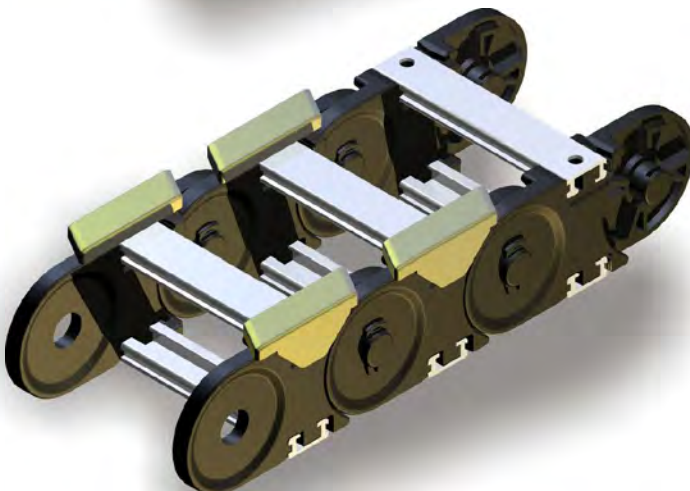

PLE 328, 528, 548

These types are suitable for long travel, the upper strand slides on the lower strand. For increased stability these energy chains are also build with stays in each link. The energy chains are fitted with sliders in the inner radius, which have a very low coefficient of friction ($\mu = 0.2$ to 0.25). After reaching the wear limit, the slider can be renewed and the energy chain will continue. Subsequent slider assembly is also possible. Then, the stays must be provided with drilled location holes.

order example:

PLE 328	/ 200	x 3500	/ 100
type	radius	length	stay length

PLE 220

standard type

height: 50 width: 86 ... 836
 inner height: 31 inner width: 50 ... 800

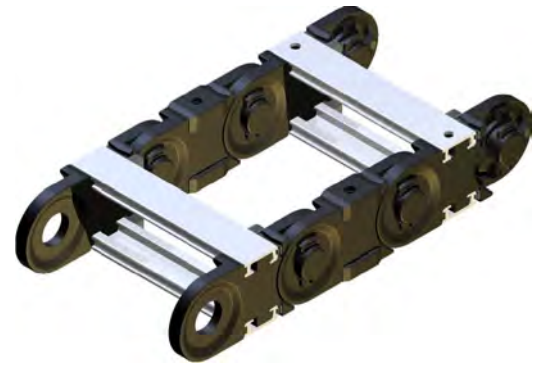

PLE 320

standard type

height: 75 width: 104 ... 944
 inner height: 49 inner width: 60 ... 900

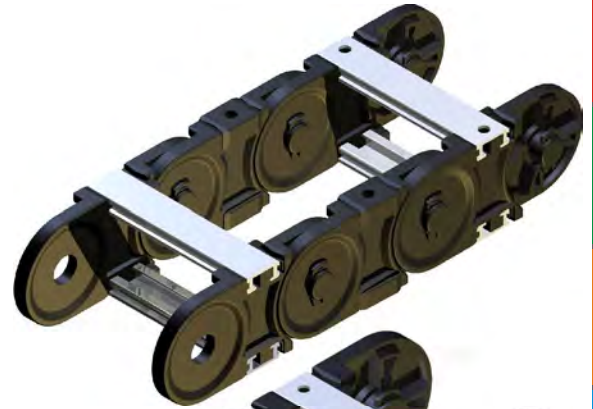

PLE 520

standard type

height: 100 width: 122 ... 1052
 inner height: 68 inner width: 70 ... 1000

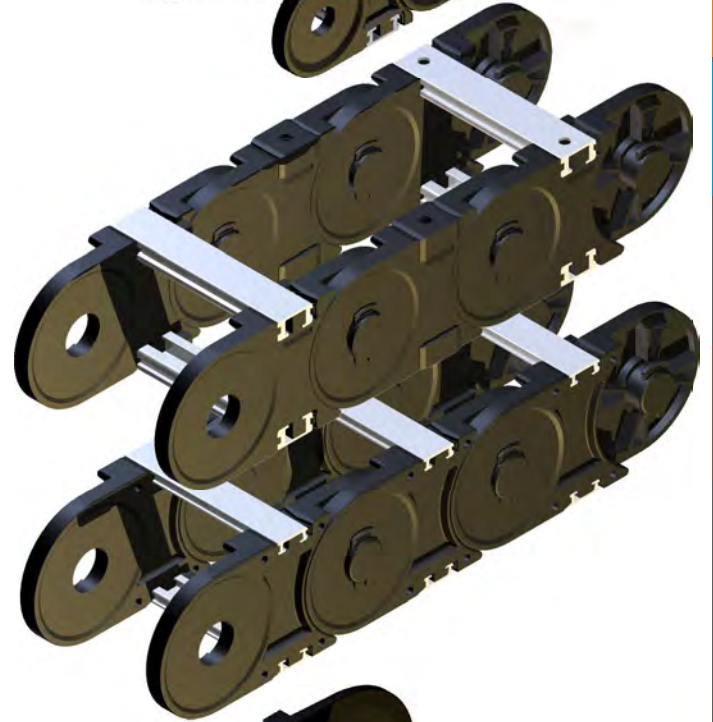

PLE 541

stay in each link

height: 100 width: 122 ... 1052
 inner height: 80 inner width: 70 ... 1000

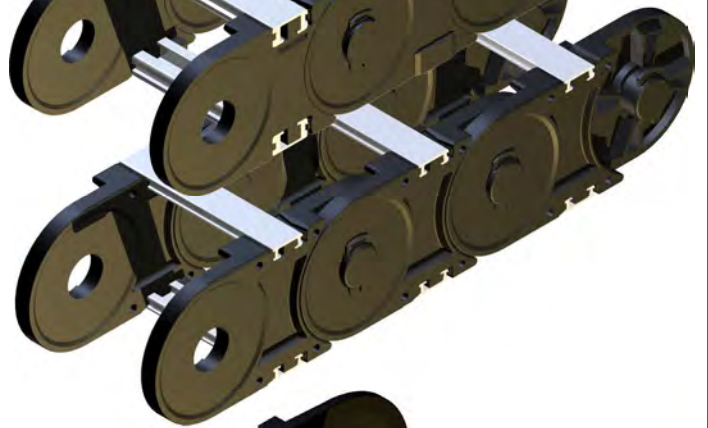

PLE 610

standard type

height: 140 width: 140 ... 1040
 inner height: 120 inner width: 90 ... 1000

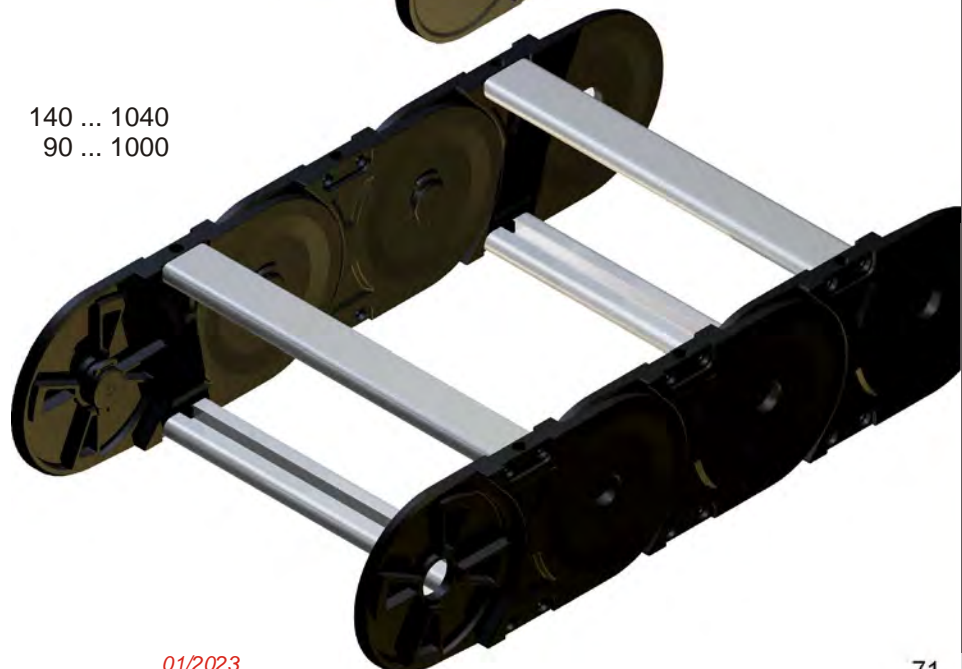

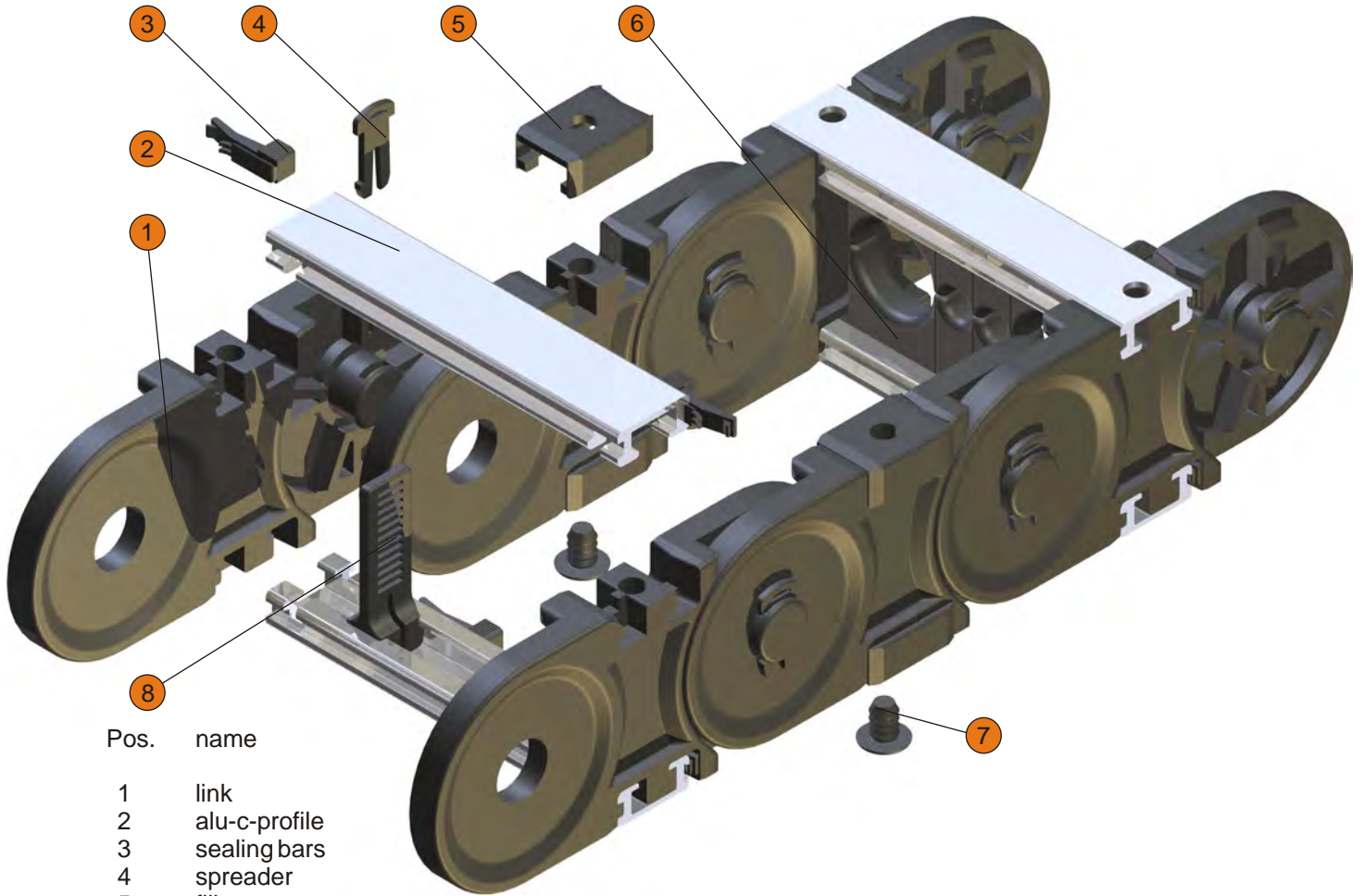

Pos.	name
1	link
2	alu-c-profile
3	sealing bars
4	spreader
5	filler
6	insert
7	damping element
8	plastic vertical divider (PZ)
9	inner cover
10	outer cover

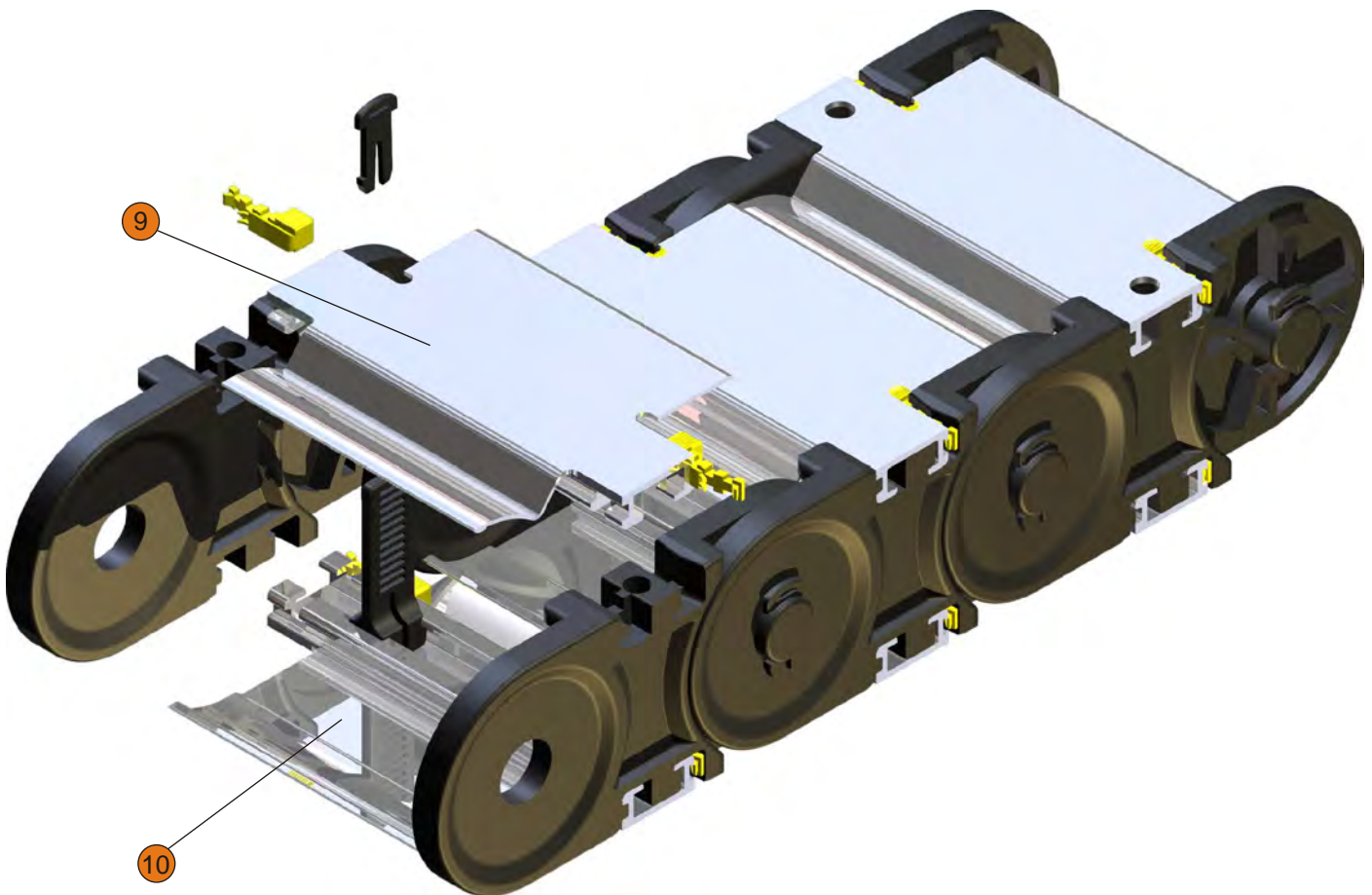

Lengthening or shortening, link bands

To shorten the spreaders are disengaged (1), taken from (2,3) and the corresponding piece of chain removed (4). Lengthening is done by adding links and inter-lock with the spreaders. Alternatively, first part of strands assembled or dismantled. Then a stay assembly or disassembly is required.

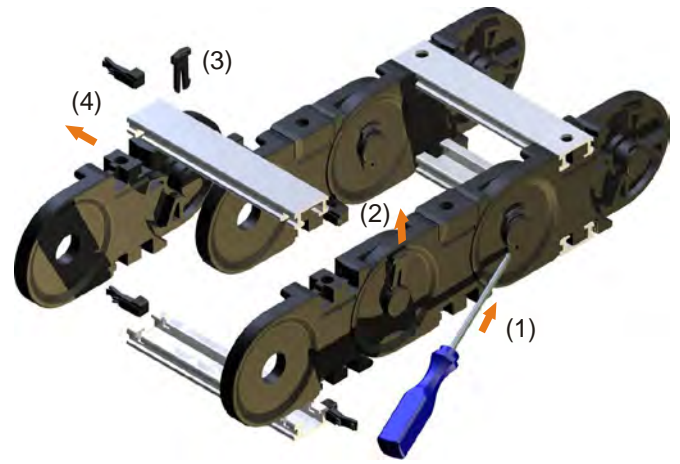

Stay assembly

Stays are installed (1) and locked by horizontal shifting into place (2). Then pushing the sealing bars outside until they lock the link.

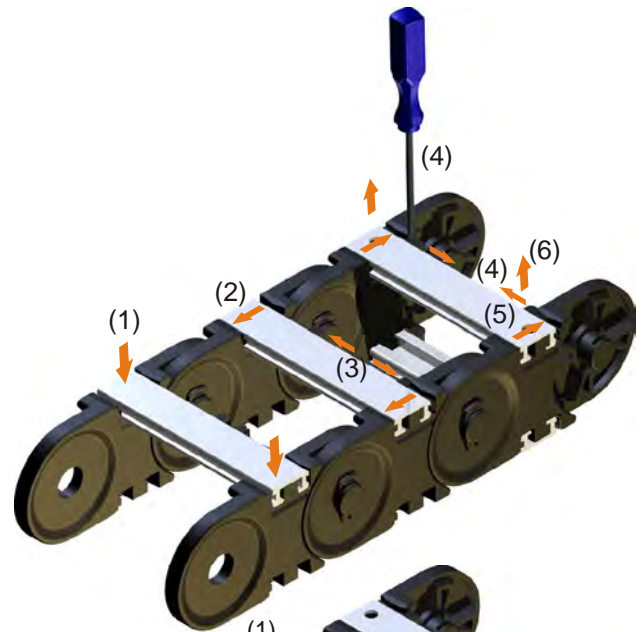

Stay disassembly

Push sealing bar to the inside (4), unlock stay (5) and remove them (6).

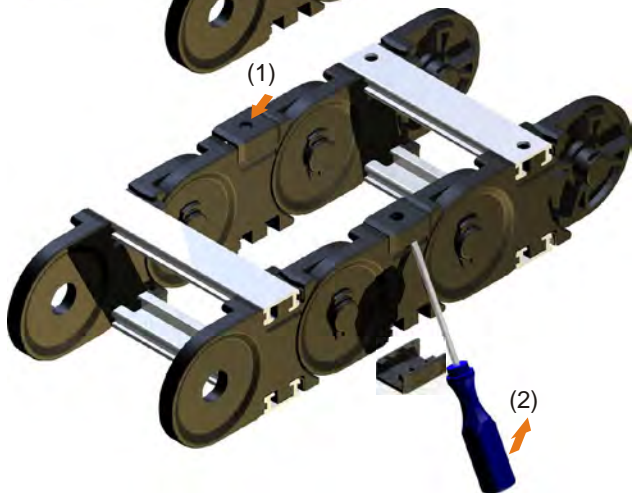

Filler

The fillers are mounted in the recess and (possibly with a light plastic hammer) pushed until locked (1). The dismantling of the fillers is done with a screwdriver. The screwdriver blade ought to be small enough to start behind the filler. Then unhinge the filler (2).

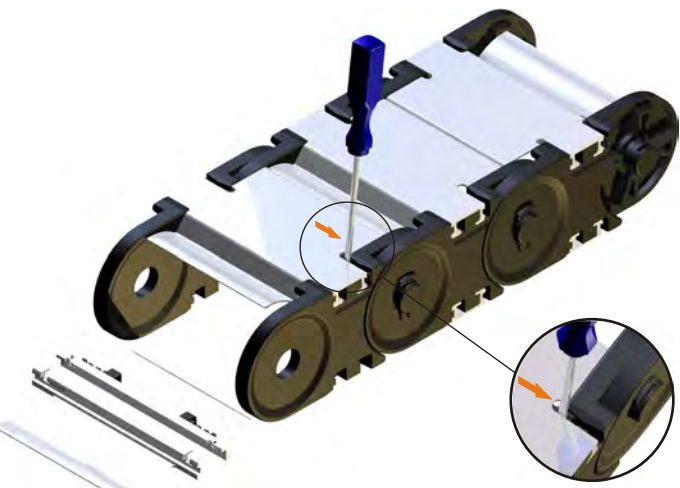

Covers

The assembly of the covers is the same as the assembly and disassembly of the stays. The sealing bar is positioned in the designated position with a screwdriver.

Plastic inserts

The inserts are assembled according to the required lateral position (1) and inserted into the stay (2).

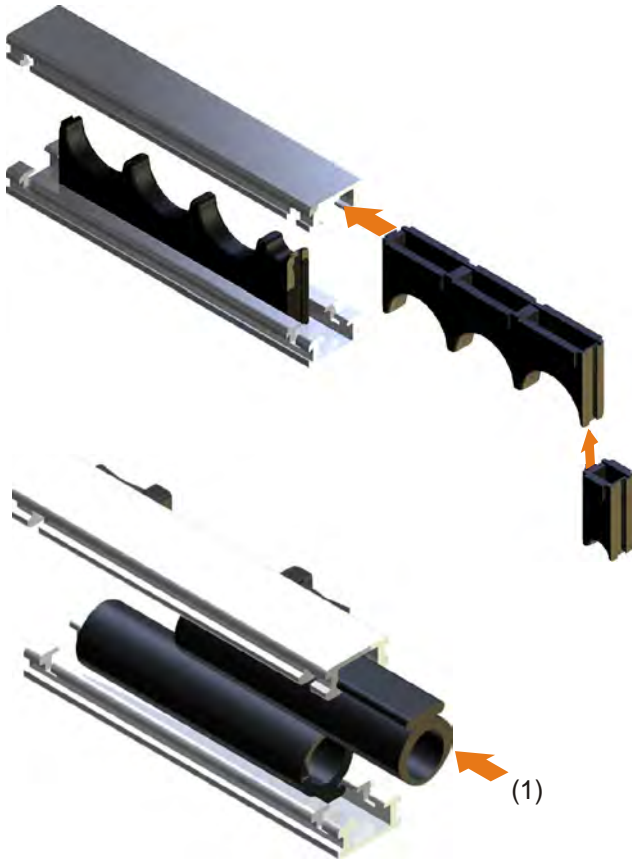

Foam

The foam insert is pushed laterally into the aluminum-profile (1), before they are assembled to the chain links.



Plastic divider PZ

The plastic dividers are hooked into the desired position with the long side of the foot in the aluminum bar and engaged with slight pressure (1).

Corrections of the position by lateral displacement are possible. The dismantling of the PZ is done by pulling in the opposite direction or sideways push out from the stay.

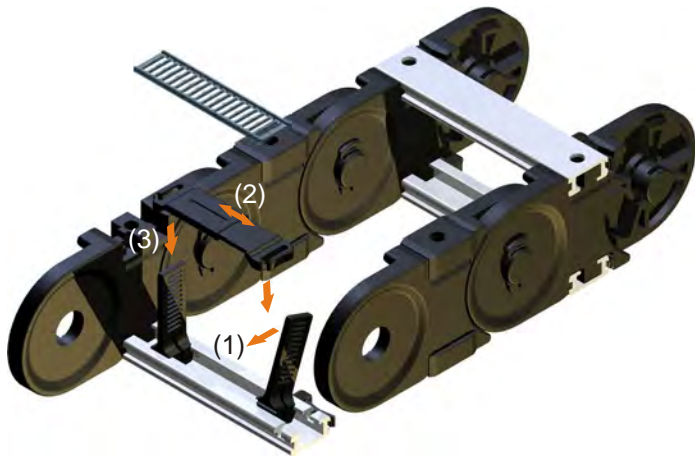

Telescopic horizontal divider

The telescopic horizontal divider can be adjusted in length (2), vertically fitted on the PZ (3) and engaged in the designated height.

The dismantling is carried out with a screwdriver by unlocking and removal.

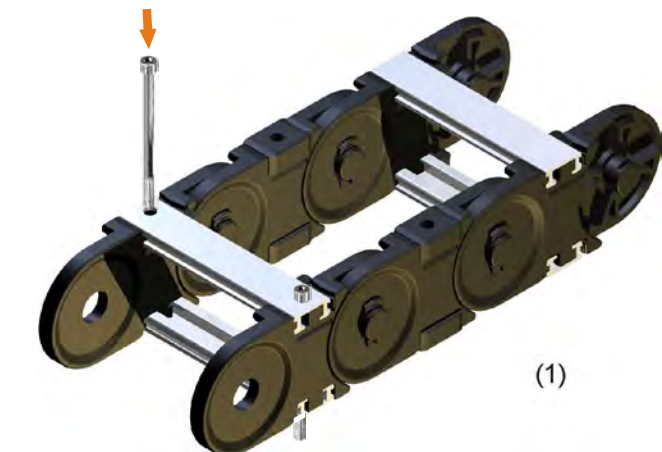

Mounting the energy chain

All ekd plastic energy chains are equipped with **integrated connectors**. They allow the mounting of the energy chain with any link.

In gliding energy chain applications or for a smooth optical effect, the mounting holes in the fixed connector can be countersunk.

Face mounting

The energy chain PLE can be optionally fitted with flange connectors. The flange connectors allow various mounting opportunities, mounted like chain links and secured with a stay.

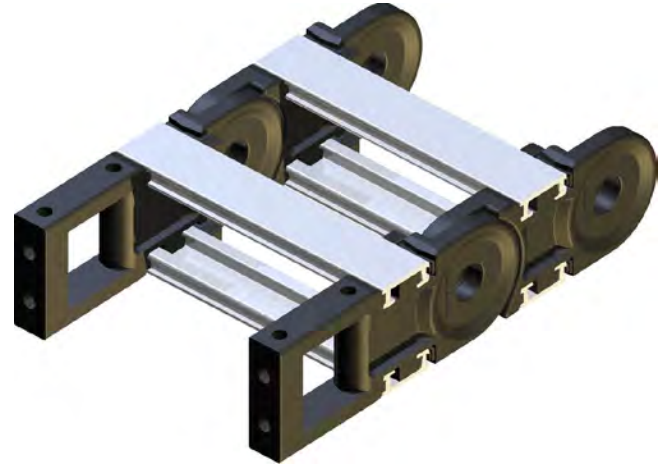

Sliders

To avoid damage the slider must be conditioned (overnight storage in water at room temperature or 2 h at 80 °C).

The slider is positioned at the inner radius of the energy chain, with the pin in the bore of the stay (1) and pushed until the snap hook locks (2).

To dismantle unhinge the snap hook (3) and remove the slider to the top (4).

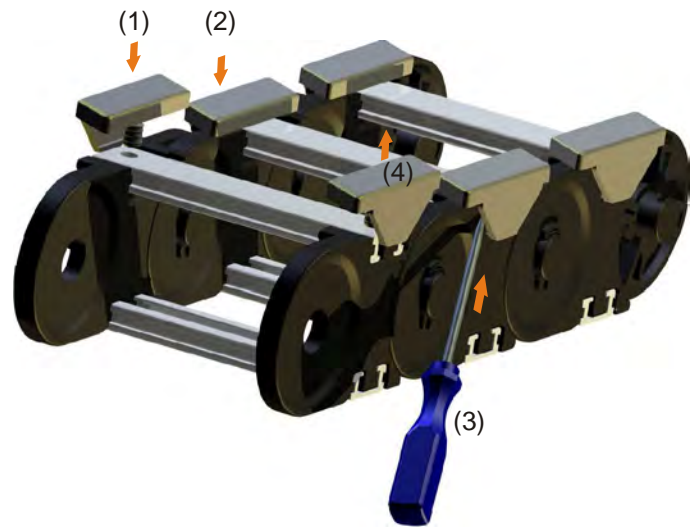

The implementation of an energy chain with sliders has to be done smoothly. In addition, the glide bars (1) should be fitted with contour at the end of the energy chain and counter sinking the connector screws (2). The distance between the glide bar to the first slider should be less than the slider length (3).

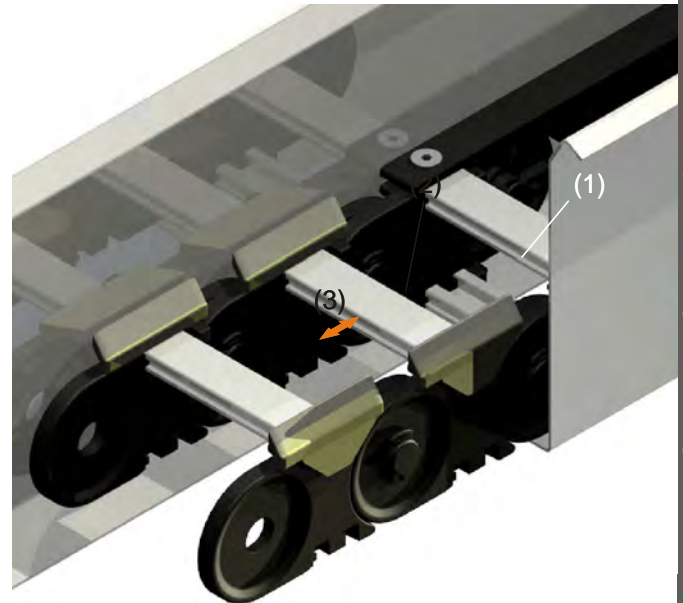

Maintenance of the energy chain

PLE energy chains are maintenance free. Like every mechanical system this will depend on the ambient conditions so wear will occur which must be observed.

In case of the energy chain has to be replaced.

For long travels or in a circular motion, the energy chains are often equipped with sliding elements. These allow sliding of the upper part of the chain on a suitable surface (eg, slider-slider, slider-steel, glide bar).

The sliders wear depends on the application. The slider surfaces should be checked at regular intervals. With a thickness of 1-2 mm sliders have to be replaced.

PLE parts 72

special material parts like UI94 V-0, EX or other have to be named in the order

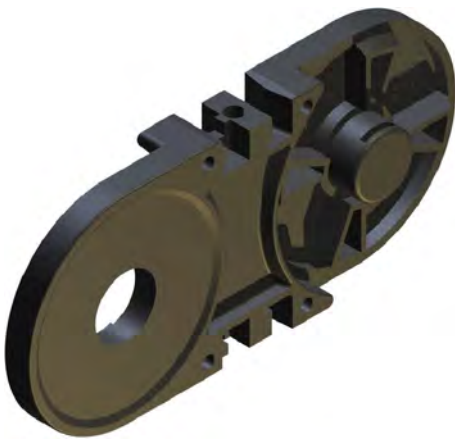

1

PLE	link							
	R	75	100	150	200	300		
220	m.V.	0346	1190	1219	1191	1192		
	o.V.	1193	1194	1218	1195	1196		
221	m.V.	0346	1190	1219	1191	1192		
	o.V.	1193	1194	1218	1195	1196		
	R	150	200	250	300	400		
320	m.V.	0351	1197	1198	1199	1200		
	o.V.	1201	1202	1203	1204	1205		
321	m.V.	0351	1197	1198	1199	1200		
	o.V.	1201	1202	1203	1204	1205		
325	m.V.	0351	1197	1198	1199	1200		
	o.V.	1201	1202	1203	1204	1205		
328	m.V.	-	1197	1198	1199	1200		
	o.V.	-	1202	1203	1204	1205		
	R	200	250	300	400	500		
520	m.V.	0944	1206	1207	1208	1209		
	o.V.	1211	1212	1213	1214	1215		
521	m.V.	0944	1206	1207	1208	1209		
	o.V.	1211	1212	1213	1214	1215		
525	m.V.	0944	1206	1207	1208	1209		
	o.V.	1211	1212	1213	1214	1215		
528	m.V.	-	1206	1207	1208	1209		
	o.V.	-	1212	1213	1214	1215		
	R	200	250	300	400	500		
541	m.V.	1611	1607	1608	1609	1610		
	o.V.	-	-	-	-	-		
548	m.V.	1611	1607	1608	1609	1610		
	o.V.	-	-	-	-	-		
R	219	250	315	410	500	700	315/1600	
610	m.V.	2407	2408	2409	2410	2411	2412	2413
	o.V.	-	-	-	-	-	-	-
611	m.V.	2407	2408	2409	2410	2411	2412	2413
	o.V.	-	-	-	-	-	-	-
615	m.V.	2407	2408	2409	2410	2411	2412	2413
	o.V.	-	-	-	-	-	-	-

PLE PART NUMBERS

4



5



7



2



3



10

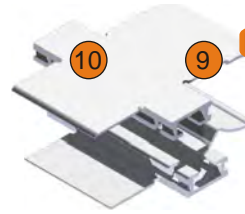

9



PLE parts

72

PLE

SR

PS

FK

C-profile

SRR/SRR5

ASA

ASI

foam

220	0348	0345	1269	0976	0344		-	-	-
221	0348	-	1269	0976	0344		-	-	-
320	0353	0350	1317	0977	0349		-	-	2365
321	0353	-	1317	0977	0349		-	-	2365
325	0353	-	1317	-	1668 1669		1640	1638	2365
328	0353	-	1317	0977	0349		-	-	2365
520	0358	0943	1317	0978	0942		-	-	2365
521	0358	-	1317	0978	0942		-	-	2365
525	0358	-	1317	-	1656 1657		1641	1639	2365
528	0358	-	1317	0978	0942		-	-	2365
541	0358	-	1317	0976	1676		-	-	-
548	0358	-	1317	0976	1676		-	-	-
610	0358	-	-						
611	0358	-	-						
615	0358	-	-		1961				

PLE parts 72

8



PLE	PZ	PTF	PT 55	PT 75	LL 25	LL 50	LS	GL	ZL	ZLA8	ZLS10	ZHS10	SDA Drilling Pin
-----	----	-----	-------	-------	-------	-------	----	----	----	------	-------	-------	---------------------

220	0778	1519	1927	0879	0880	1663	1664	1665	-	1273	1159	1160	1407	1439 1761
221	0778	1519	1927	0879	0880	1663	1664	1665	-	1273	1159	1160	1407	1439 1761



320	0163	1678	1927	0879	0880	1663	1664	1665	-	1273	1159	1160	1407	1773 1774
321	0163	1678	1927	0879	0880	1663	1664	1665	-	1273	1159	1160	1407	1773 1774
325	0163	1678	1927	0879	0880	1663	1664	1665	1450	1273	1159	1160	1407	1773 1774
328	0163	1678	1927	0879	0880	1663	1664	1665	1450	1273	1159	1160	1407	1773 1774



520	0719	1680	1927	0879	0880	1663	1664	1665	-		1159	1160	1407	1775 1776
521	0719	1680	1927	0879	0880	1663	1664	1665	-		1159	1160	1407	1775 1776
525	0719	1680	1927	0879	0880	1663	1664	1665	1449		1159	1160	1407	1775 1776
528	0719	1680	1927	0879	0880	1663	1664	1665	1449		1159	1160	1407	1775 1776

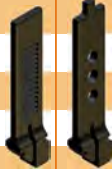

541	1613		1927	0879	0880	1663	1664	1665	-	1675	1159	1160	1407	
-----	------	--	------	------	------	------	------	------	---	------	------	------	------	--

548	1613		1927	0879	0880	1663	1664	1665	1449	1675	1159	1160	1407	
-----	------	--	------	------	------	------	------	------	------	------	------	------	------	--



610	1110	1933	-	-	-	-	-	-	-		1159	1160	1407	
611	1110	1933	-	-	-	-	-	-	-		1159	1160	1407	

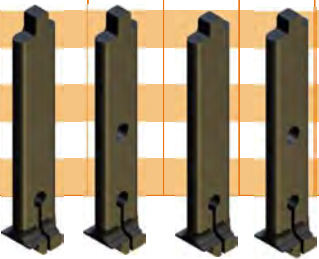

PLE PART NUMBERS

inserts

special material parts like UI94 V-0, EX or other have to be named in the order

6

diameter in mm



PLE

10 15 20 25 30 35 40 45 50 55 60 65 70



220	0649	0650	0651	0652	0653	-	-	-	-	-	-	-	-
221	0649	0650	0651	0652	0653	-	-	-	-	-	-	-	-



320	0654	0665	0656	0657	0658	0659	0660	0661	0662	-	-	-	-
321	0654	0665	0656	0657	0658	0659	0660	0661	0662	-	-	-	-
325	0654	0665	0656	0657	0658	0659	0660	0661	0662	-	-	-	-
328	0654	0665	0656	0657	0658	0659	0660	0661	0662	-	-	-	-



520	1628	0663	0664	0665	0666	0667	0668	0669	0670	0671	0672	0714	0715
521	1628	0663	0664	0665	0666	0667	0668	0669	0670	0671	0672	0714	0715
525	1628	0663	0664	0665	0666	0667	0668	0669	0670	0671	0672	0714	0715
528	1628	0663	0664	0665	0666	0667	0668	0669	0670	0671	0672	0714	0715

SLE

- SLE applications 81
- SLE dimensions 82
- SLE types 84
- SLE sizes 86
- SLE parts 87
- SLE assembly 88
- SLE connectors 83
- SLE part numbers 92
- SLE accessories 98

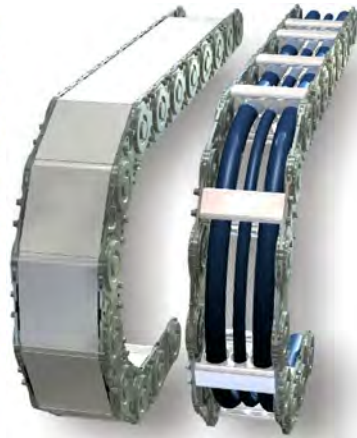

closed + open

SLE CHARACTERISTICS

The SLE is available as **SLA** with aluminium T- or slot-profile, as **SLE** with plastic inserts or plastic slot profile, as **SLS** with foam slot profile, as **SLP** with plastic divider PZ or as **SLR** with pipe or roll stays.



In steel, stainless steel and hardened material is the steel chain in case of large free carrying lengths, large quantities of cables and heavy-duty hydraulic hoses first choice.

- stay distributions in many variants
- stay fast assembly and disassembly
- simple shortening and lengthening
- shroud protecting pivot mechanics

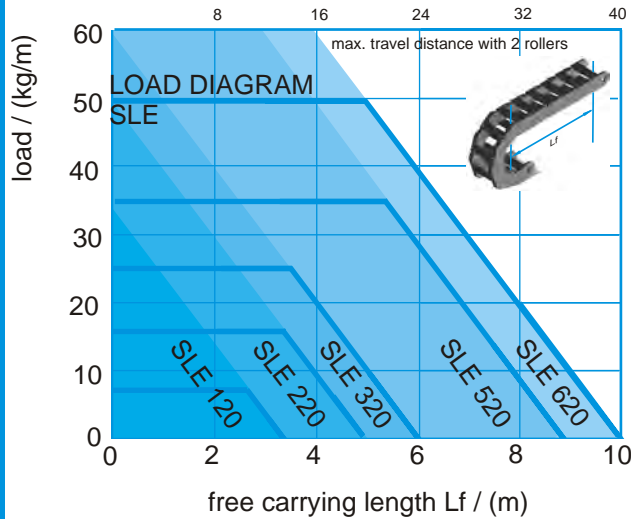

Travel

The maximum travel distance is determined by the arrangement and the additional weight (line weight). At normal arrangement the maximum travel is twice the free carrying length. Support rollers or similar constructive steps can increase this value. In gliding arrangement travel distances up to 100 meters are possible (application dependent). Exceeding this value additional constructive action is needed (see design guidelines).

Travel speed

The standard and the stainless steel design is limited at 1m/s. Exceeding this and high dynamic loads caused by e.g. vibrations or high number of cycles require the use of the hardened (carburised) material.

Acceleration

The acceleration in principle is not limited. Limits are achieved, by very long chains and line weight that cause extreme tensile forces.

Temperature

The long term operating temperature is -20 °C to 600 °C (-40 °C stainless steel to 600 °C).

Special types

- Stainless Steel
- Carburised (hardened)



application fields

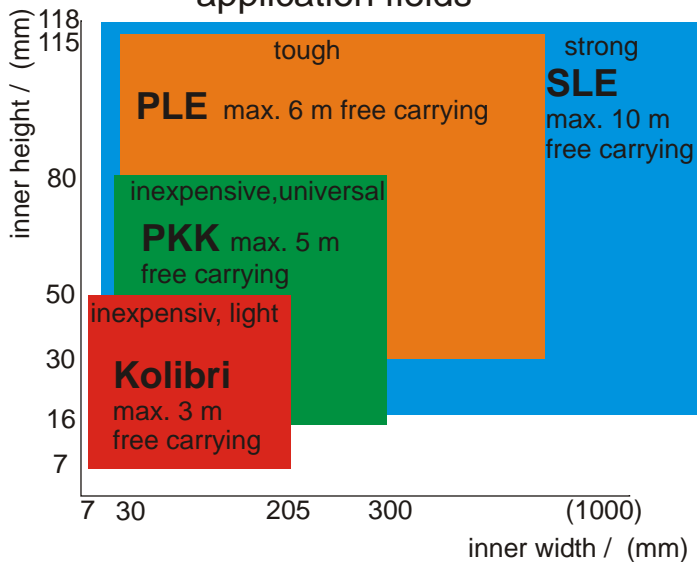

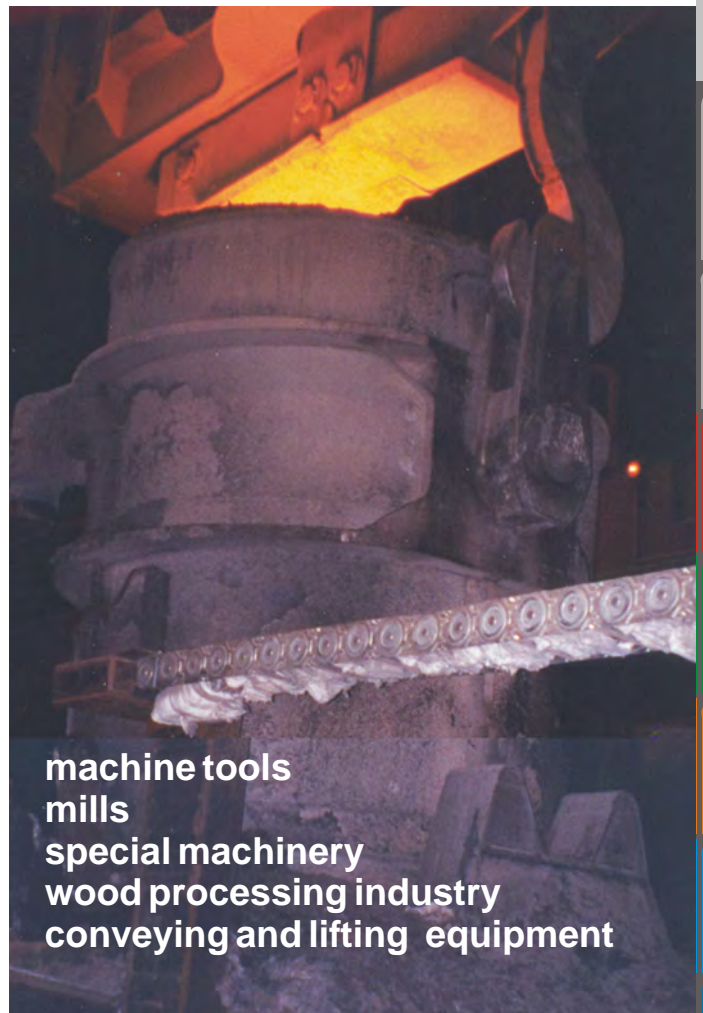

machine tools
mills
special machinery
wood processing industry
conveying and lifting equipment

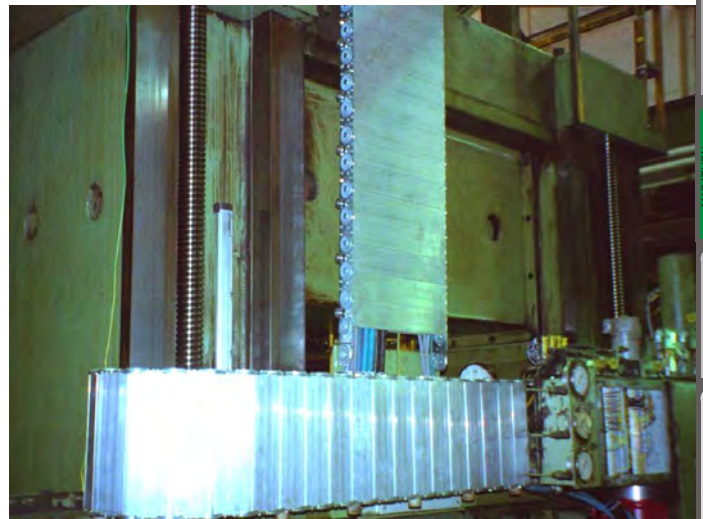
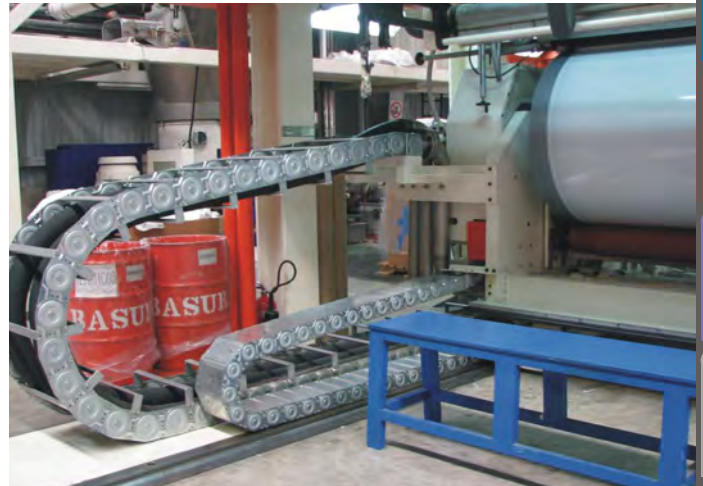
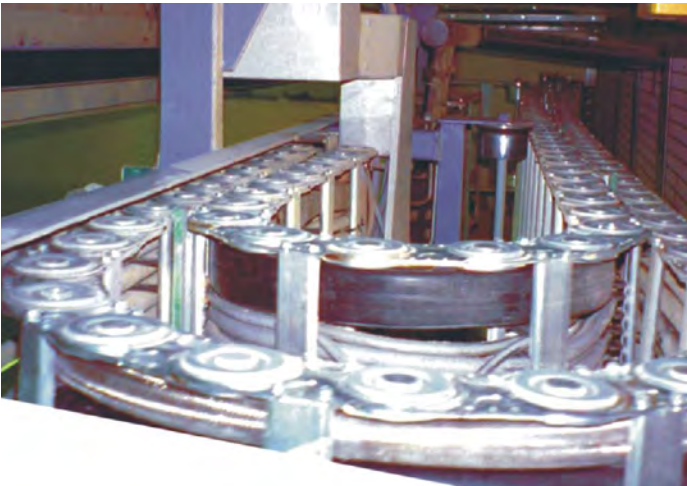

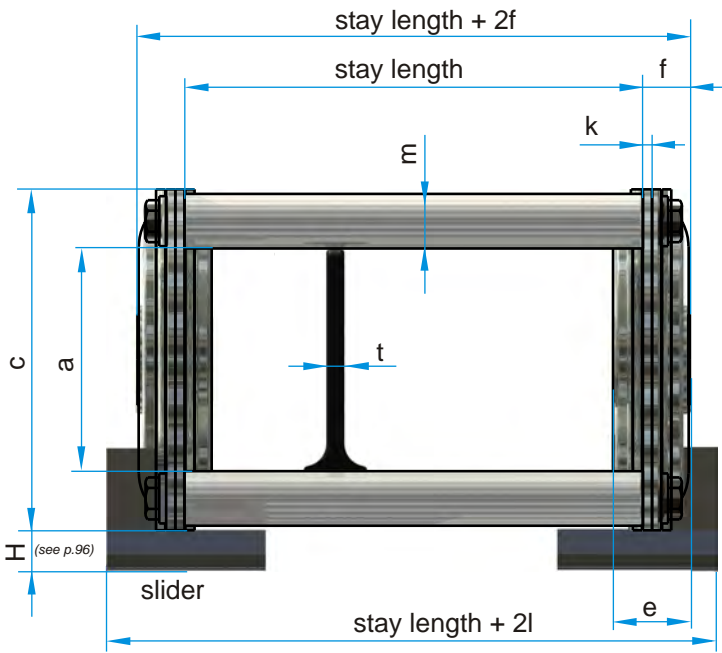

the usable interior width is stay length - 2(e-f)

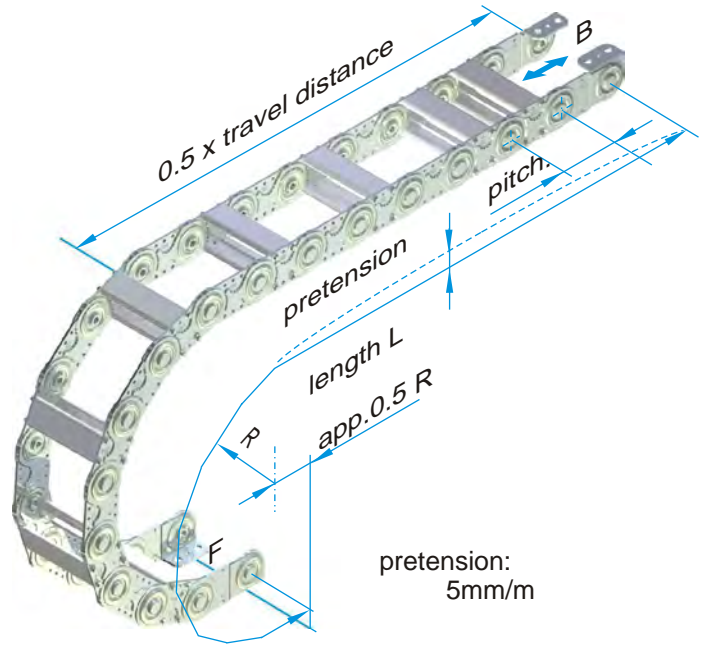

SLE	pitch	a	c	e	f	g	h	k	l ¹⁾	m	o	p	t	weight [kg/m]
120, 121, - , 128	50	20	35	10	6	7,5	7	1	9	7	10	20	4	2.3
220, 221, 225, 228	75	31	50	14	8	12	9	1,5	13	9	12	30	4	4.3 (5.8)
320, 321, 325, 328	100	49	75	17	11	17	11	2	18	12	12	50	4	7.9 (9.6)
520, 521, 525, 528	125	68	100	23.5	14	22	13	3	20	15	12	70	4	15.1 (16.9)
620, 621, 625, 628	175	118	150	23.5	14	26	13	3	20	15	24	115	8	19.3 (20.9)

the weight is given for the standard type with with a stay length of 100, values in brackets for closed version
 1) stay length + 2l is the width of the chain with sliders

bending radius R [mm]

120, 121, - , 128			60	100	150		250								
220, 221, 225, 228				100	150	200	250	300							
320, 321, 325, 328 ¹⁾					150	200	250	300	400						
520, 521, 525, 528 ¹⁾						200	250	300	400	500					
620, 621, 625 ²⁾ 628 ¹⁾							250	300	400	500	600				

¹⁾ SLE 328 from R200, SLE 528 from R250, SLE 628 from R300 ²⁾ SLE 625 from R300

the stay lengths are offered in steps of 1 mm

stay length SLE plastic inserts Ø [mm]



120, 121, - , 128	40 ... 800														
220, 221, 225, 228	50 ... 900	10	15	20	25	30									
320, 321, 325, 328	60 ... 1000	10	15	20	25	30	35	40	45	50					
520, 521, 525, 528	70 ... 1200	10	15	20	25	30	35	40	45	50	55	60	65	70	
620, 621, 625, 628	100 ..1200														

order example:

travel distance 3 m, bending radius 200 mm,
 cables: 1x15 mm, 8x8 mm, 3x12 mm, 2x22 mm, normal arrangement

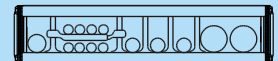

SLP 220 / 200 x 2325 / 200 /N/N¹⁾ / 5 PZ 1 PT55
 type / radius x length / stay length / connectors / arrangement / stay distribution

1) 1. fixed connector / 2. moving connector

Normal connector in outer radius

connector **E** in inner radius

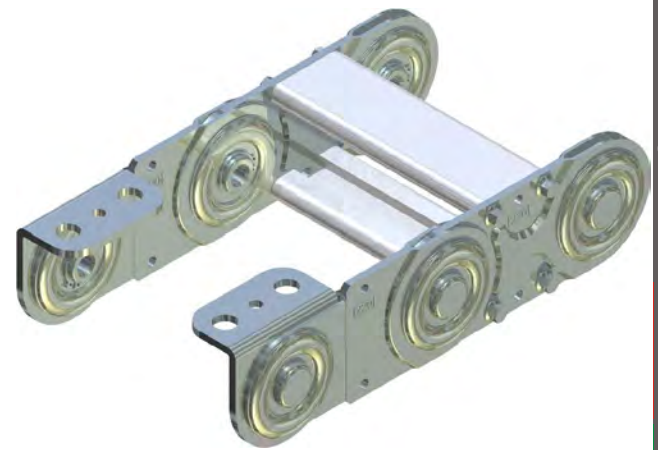
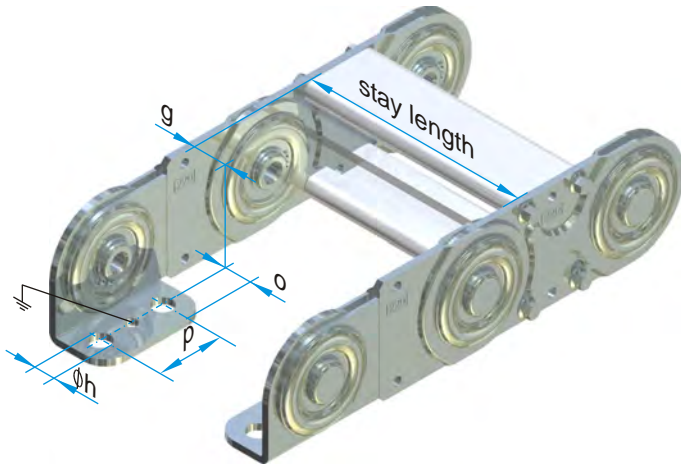

SLE	connector screws
120	M 6
220	M 8
320	M10
520	M12
620	M12

connector **A**

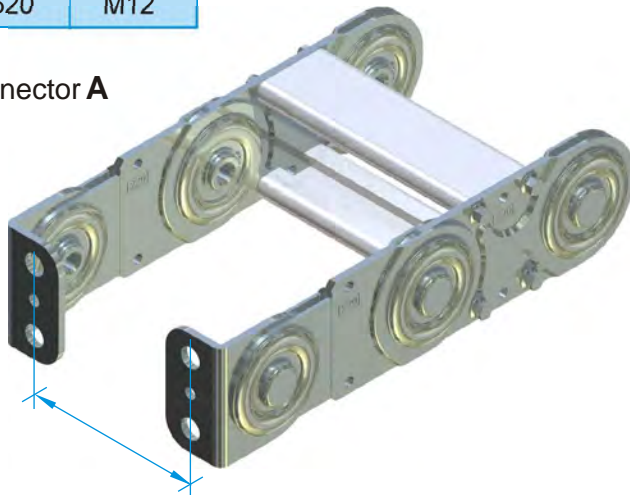

connector **B**

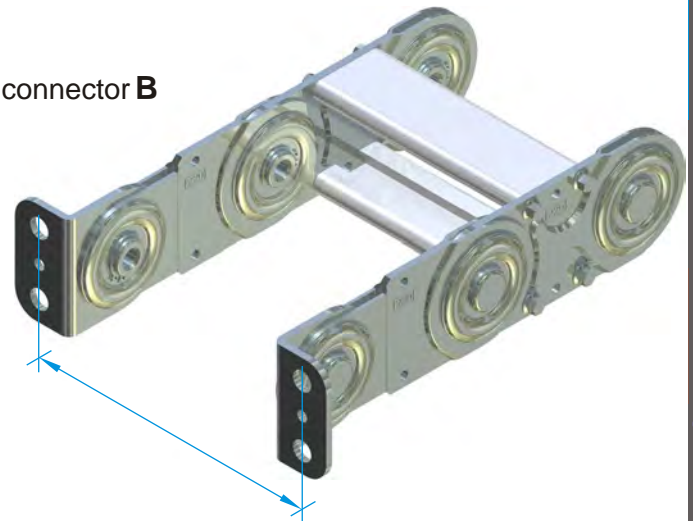

connector **A** dimension = staylength - 2g

connector **B, C, D** dimension = staylength + 2g + 4k

connector **C** in outer radius
(corresponding to connection dimension **B**)

connector **D** in inner radius
(corresponding to connection dimension **B**)

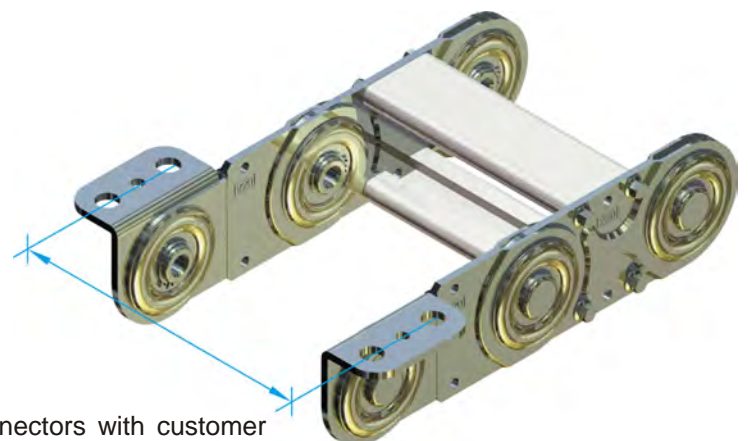
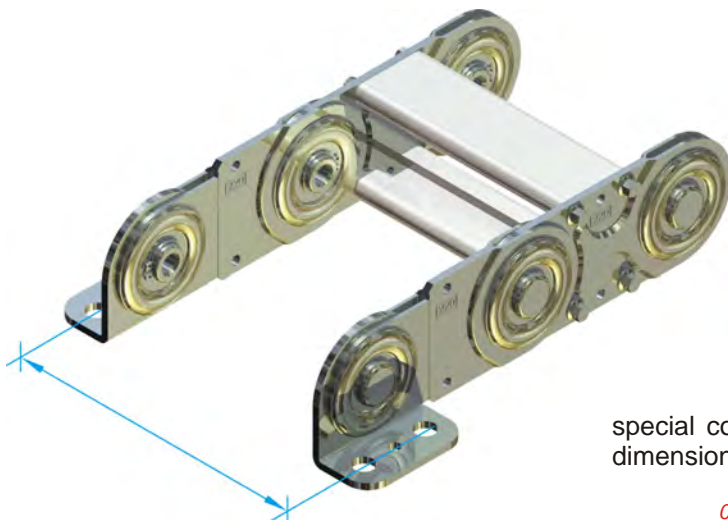

special connectors with customer dimensions are available

SLE TYPES

SLE 120, 220, 320, 520, 620

The standard type is built with stays in every second chain link. The steel link energy chains can be opened in the inner and in the outer bending radius.

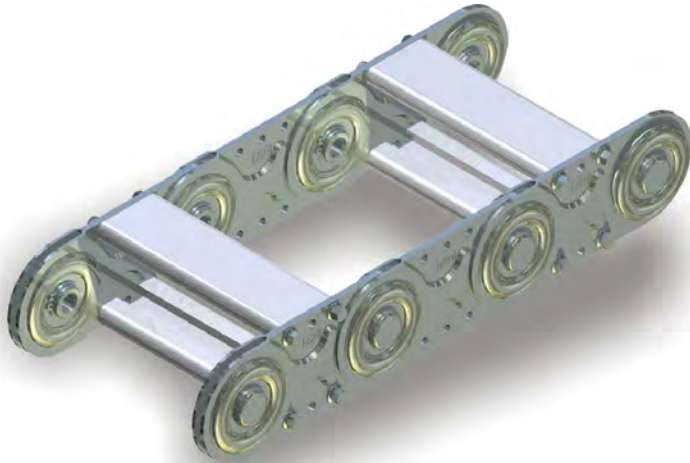

order example

SLP 120	/ 100	x 2050	/ 100	/ D	/ E	/ h	/ 2PZ
type	radius	length	stayw.	connect.	arran.	stay dist.	

SLE 121, 221, 321, 521, 621

These designs are made with stays in each link. This increases the lateral stability and improves the guiding particularly of smaller diameter lines.

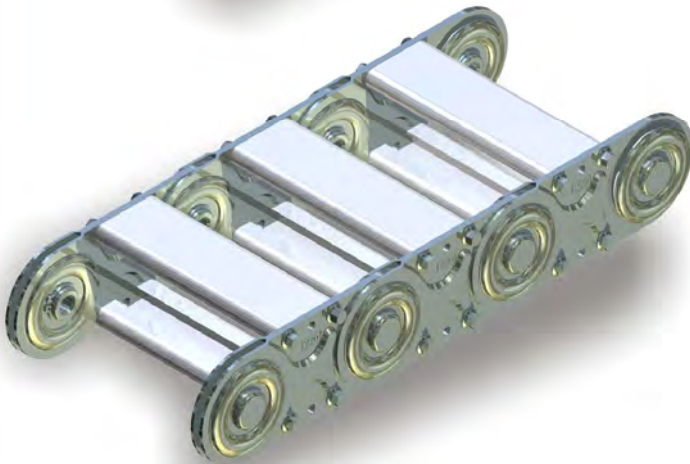

order example

SLP 321	/ 100	x 3100	/ 200	/ N	/ N	/ n	/ 5PZ, 3PT
type	radius	length	stayw.	connect.	arran.	stay dist.	

SLE 225, 325, 525, 625

The closed types offer optimum protection of the lines against dust and cuts or other environmental influences. At higher temperatures the covers **Silver Star** provide excellent protection.

The closed types also may be built to replace the standard version stay.

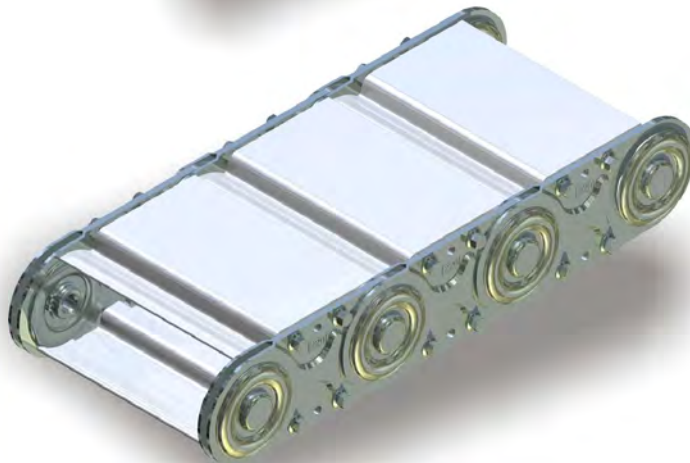

order example

SLP 225	/ 200	x 2550	/ 150	/ N	/ N
type	radius	length	stayw.	connectors	

SLE 128, 228, 328, 528, 628

These types are suitable for long travel, the upper strand slides on the lower strand. For greater stability these energy chains are built with stays in each link. The energy chains are fitted with sliders, which have a very low coefficient of friction ($\mu = 0.2$ to 0.25).

After reaching the wear limit the slider can be renewed and the energy chain will continue.

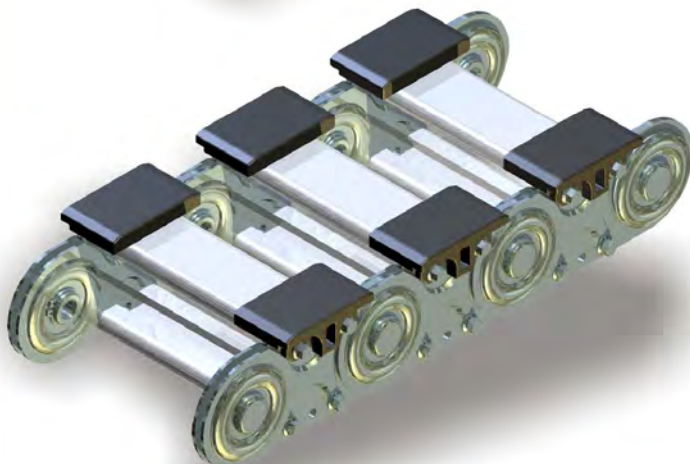

order example

SLP 328	/ 200	x 45000	/ 250	/ N	/ N	/ g	/ 3PZ
type	radius	length	stayw.	connect.	arran.	stay dist.	

Compared to standard chains the SLE series is characterized by the fact that the sturdy aluminium profile can be steplessly adapted to the requirements. Stay lengths of up to 1500 mm can be provided. The subdivision of the interior satisfies every requirement and guarantees optimized cable protection, even at very high accelerations and travel speeds.

The **SLA** (SLE with aluminum T-profile or aluminium slot-profile) is a highly customized and robust energy chain, which is chosen primarily for larger dimensions. The stays are milled in accordance with the requirements of the user with individual hole patterns.

For extreme applications, the variants SLA, SLS and SLE should be preferred, since these offer optimize cable guiding. In the case of high speed and acceleration a multi-layer arrangement of the cable should be avoided.

The **SLE** (SLE with plastic inserts or plastic slot-profile) ensures at high speeds a perfect guide and almost excludes errors during installation of the lines. With this design the hole pattern of the stays can be adjusted accurately to the needs of the lines. Plastic inserts are available in a 5 mm grid. The plastic slot-profile can be ordered to suit special requirements.

For limited installation space, the **SLS** (SLE with foam slot-profile) are used. Again, the optimal guiding of the lines at high speeds and acceleration is ensured. Well-known automotive manufacturers have used this type for years with the best experiences. All lines lie in the neutral axis of the energy chain.

For space reasons, the **SLP** (SLE with plastic divider PZ and others) can be selected. This inexpensive design allows the guiding of large amounts of cable. The highly variable distribution possibility through small steps of (3mm) in height, plus the Telescopic divider (PT) allows maximum space for all needs, even when changes in cable diametres are required.

The **SLR** (SLE with a pipe or roll stays) is manufactured only upon request. The pipe stay allows special material combinations, such as the exclusion of aluminum or the use of stainless steel and brass. The roll bar has advantages particularly for heavy lines with high friction and wear in terms of durability of the cables and hoses: Relative movements on the energy chain are compensated by the rolling motion of the stays.

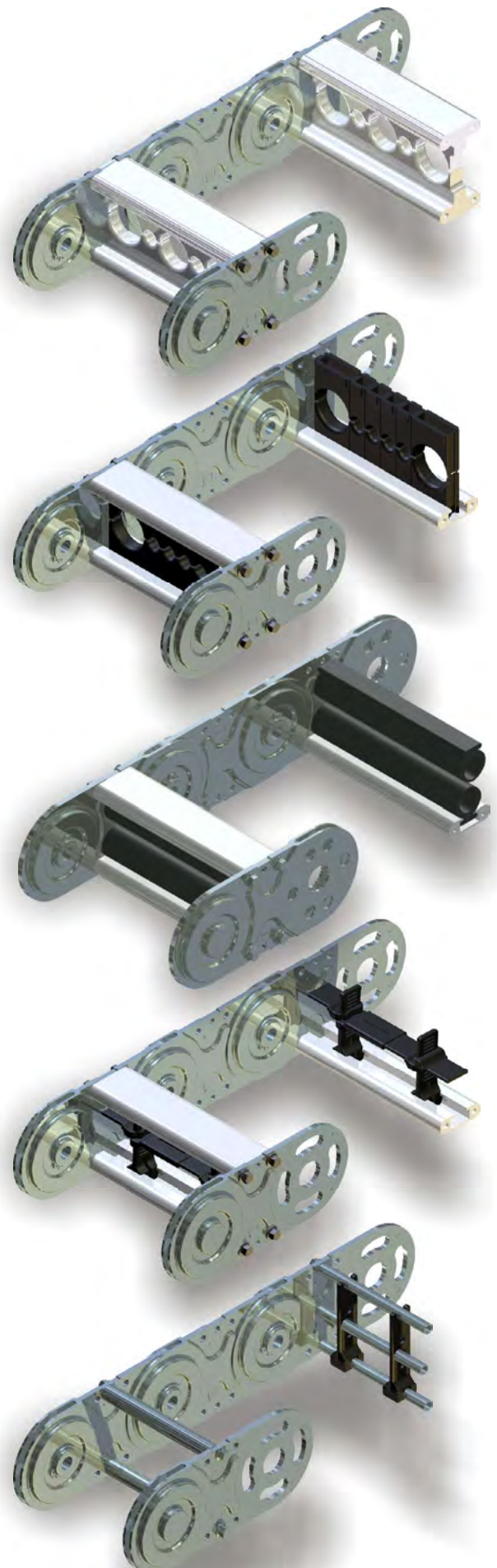



SLE 120

standard type			
height:	35	width:	52 ... 812
inner height:	20	inner width:	32 ... 792
		stay length:	40 ... 800



SLE 220

standard type			
height:	50	width:	66 ... 916
inner height:	31	inner width:	38 ... 888
		stay length:	50 ... 900



SLE 320

standard type			
height:	75	width:	80 ... 1020
inner height:	49	inner width:	50 ... 990
		stay length:	60 ... 1000

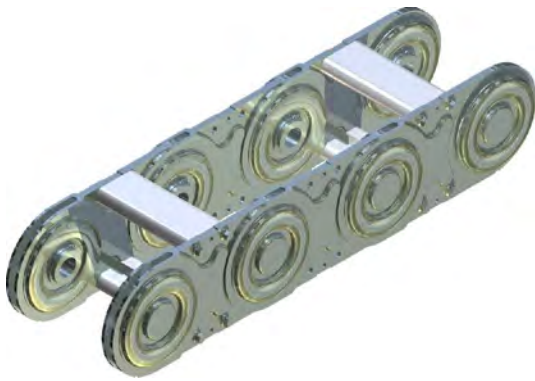

SLE 520

standard type			
height:	100	width:	98 ... 1028
inner height:	68	inner width:	54 ... 1184
		stay length:	70 ... 1500

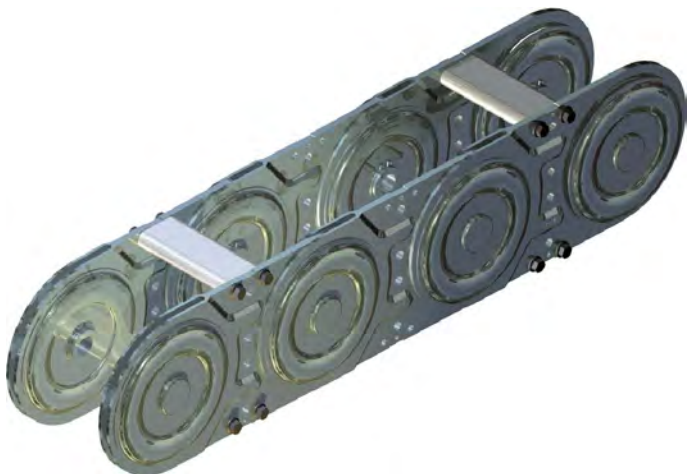

SLE 620

standard type			
height:	150	width:	128 ... 1228
inner height:	118	inner width:	84 ... 1184
		stay length:	100 ... 1500

item name

- 1 link
- 2 connector link single
- 3 connector link double
- 4 connector angle
- 5 flange bolt
- 6 radius bolt
- 7 cover plate
- 8 retaining ring
- 9 aluminum C-profile
- 10 serrated screw
- 11 plastic (vertical) divider
- 12 outer cover
- 13 distance filler
- 14 inner cover
- 15 band holder
- 16 band (steel / stainless steel)
- 17 threaded bolt
- 18 lock washer
- 19 locknut
- 20 plastic inserts
- 21 foam
- 22 slider
- 23 aluminium-T-profile
- 24 pipe stay
- 25 flange rollers

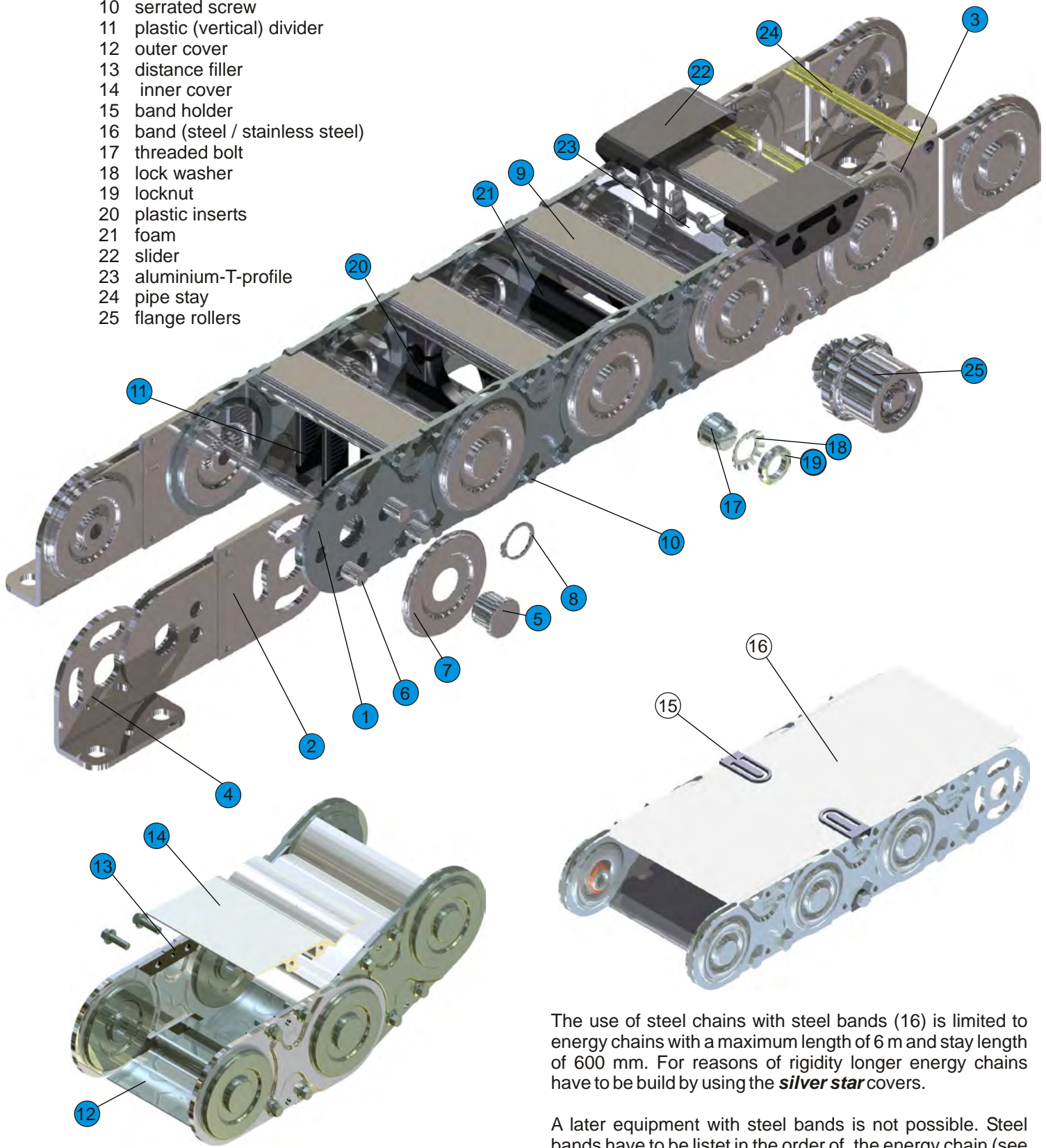

The use of steel chains with steel bands (16) is limited to energy chains with a maximum length of 6 m and stay length of 600 mm. For reasons of rigidity longer energy chains have to be build by using the *silver star* covers.

A later equipment with steel bands is not possible. Steel bands have to be listet in the order of the energy chain (see page 92 bottom).

Packaging

ekd energy chains are supplied in secured device packaging. When removing the packaging and moving the energy chains or parts of them, ensure that the energy chains are free of torsion and tension to avoid mechanical damage.

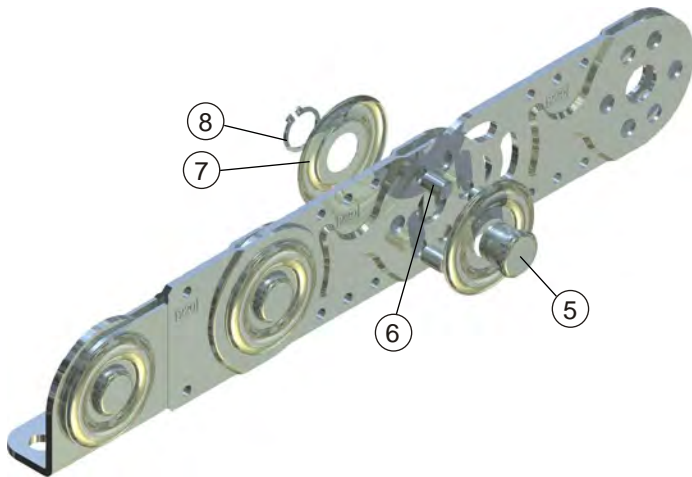

Lengthening or shortening

If energy chains are delivered in pieces, proceed with the installation as follows:

Push the link together (1) and insert the flange bolts (5) with a shroud (7) in the chain outside. Then build the radius by inserting the radius bolts (6) (see chart for correct radius). Finally put on the inner shroud (7) and fit the retaining ring (8). Roll the energy chain to check that the radius is correct throughout its length.

Shortening in the reverse order:

Loosen the retaining rings (8), pull out the flange bolts (5), lifting the shroud (7), pull the radius bolts (6) and remove the links (1).

Energy chains with threaded bolts instead of the retaining rings (8), first unlock the locking plates (18) to solve the locknuts (19). Thereafter, the threaded bolts (17) and pins (6) can be removed and taken from the links (1).

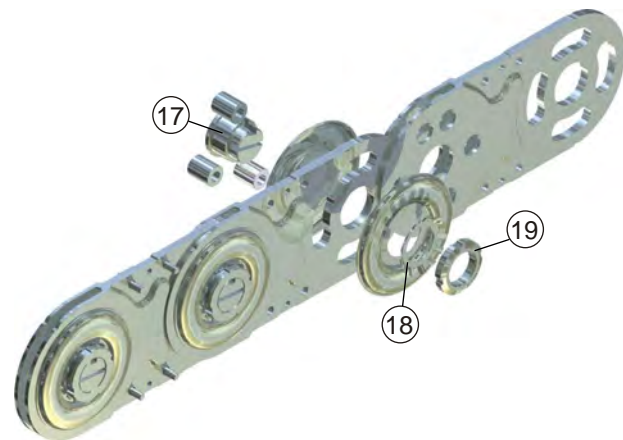

Implement the connector angle

The connector angles (4) are orientated to the outer radius and to the chain center (normal end mounted). By loosening the retaining rings (8), drag the flange bolts (5), lift off the shroud (7) and pull the radius bolts (6) the connector angles (4) can be disassembled and placed in a different position.

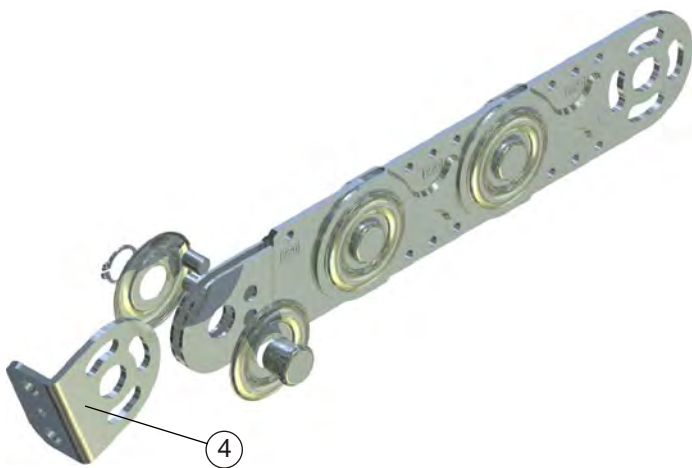

Bending radius

Loosen the retaining rings (1) and lift off the shrouds (7). Implement the radius bolts (6) according to table (page 89). Then mounting the shrouds (7) and retaining Rings (1).

The detachable bolts position for the different radii can be found engraved on the double connector links (3).

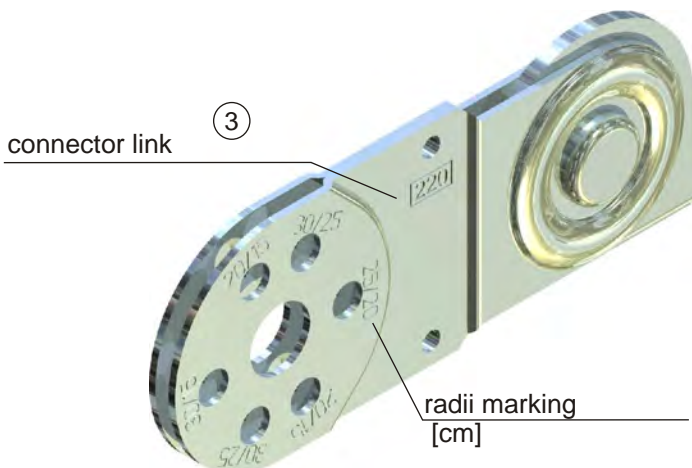

assembly of radius bolts						
SLE	120	220	320	520	620	
radius	60	100	150	200	250	<p>(marking in the outer radius)</p> <p>the minimum radius is built with only 2 bolts</p>
radius	100	150	200	250	300	<p>(marking in the outer radius)</p>
radius	150	200	250	300	400	<p>(marking in the outer radius)</p>
radius	250	250	300	400	500	<p>(marking in the inner radius)</p>
radius	-	300	400	500	600	<p>(marking in the inner radius)</p>

Stay removal

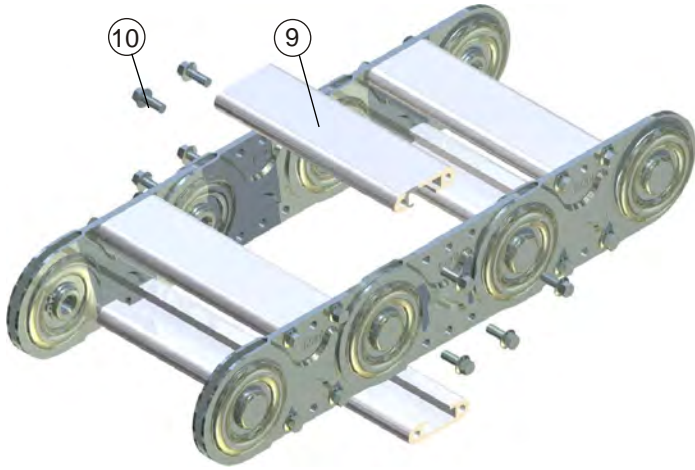

The stays (9) are fastened with serrated screws (10) to the links (1). They can be removed by unscrewing the four screws (10).

Stay lengths up to 600 mm are available with quick assembly.

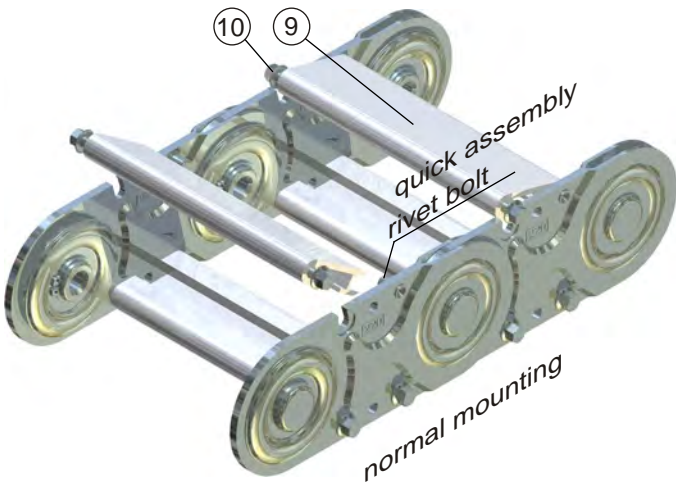

Quick assembly

In quick assembly only two screws must be tightened or loosed. The stays (9) are moved with the groove on the rivet and the serrated screw (10) snapped in the recess and tightened.

Cover Silver Star

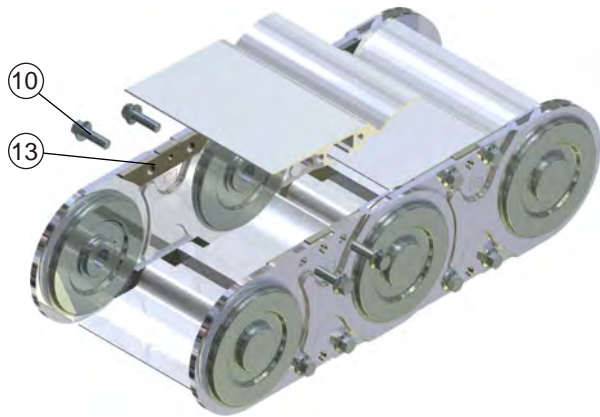

The covers of the closed version can be removed like the stays by loosening the four serrated screws (10). The spacers (13) remain on the links.

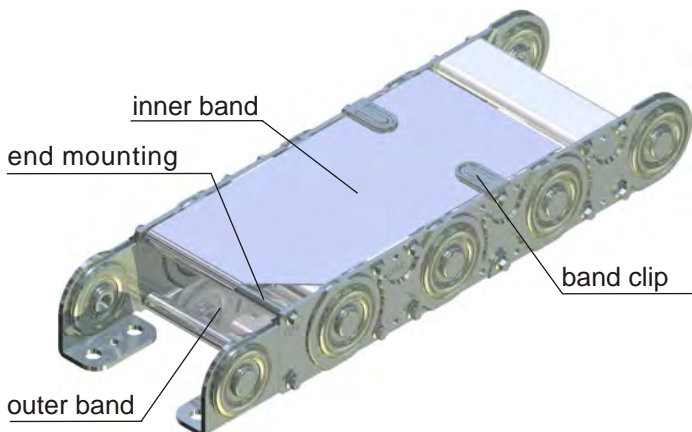

Stainless steel bands

To protect the lines against external damage and pollution the chains can be equipped with steel or stainless steel bands in the inner and outer radius. The edges of the steel bands are circular smoothed to avoid injury. Stainless steel and steel bands are fastened with band holders screwed on sides and with screwed connections on each end of the chain.

Final assembly

The installation height should not fall below the level $H = (50 \text{ plus two times bend radius plus link height})$.
The pretension of cable carrier is taken into account with the additional space of 50 mm.

First fasten fixed connection (F) and then mount the movable connection using the specified bolt size (see SLE connectors).
Compliance with the maximum free carrying length is of vital importance for the life time of the energy chain, both during the installation as well as when operational. Over travel of the energy chain can lead to damage and premature wear.

If the energy chain is provided with support elements, the assembly of these must take place before the installation of the chain in order to avoid even a short-term stress point.

An energy chain may never exceed the free carrying length without support rollers.

The height of the moved connector must be adjusted so that the connector link is moving with a maximum of 5 mm distance from the base of the supporting roller.

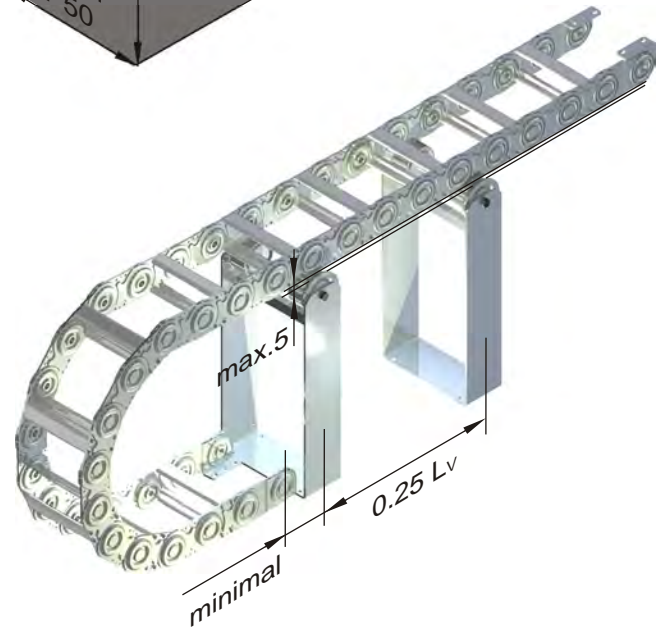
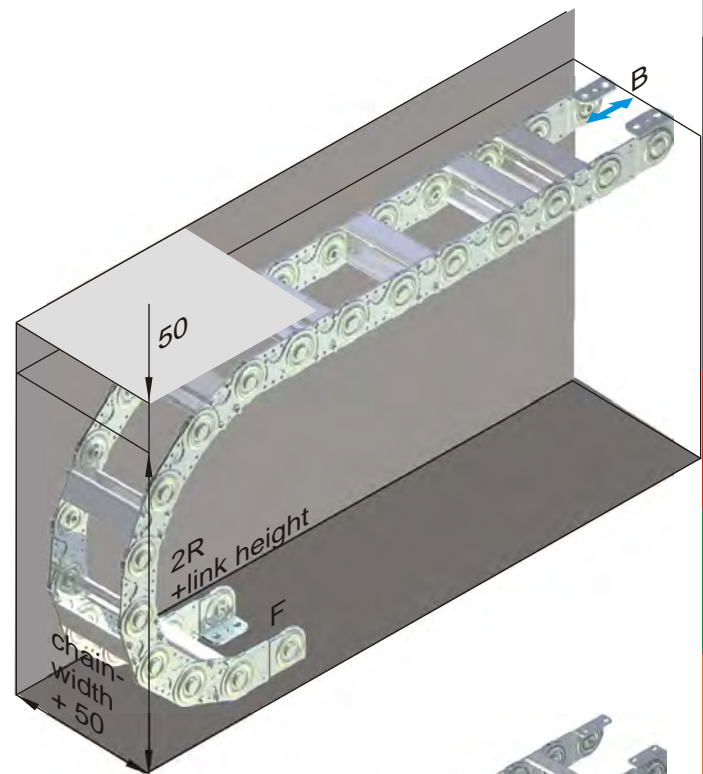

Maintenance of the energy chain

PLE energy chains are maintenance free. Like every mechanical system this will depend on the ambient conditions so wear will occur which must be observed.

In case of the energy chain has to be exchanged.

For long travels or in a circular motion, the energy chains are often equipped with sliding elements. These allow sliding of the upper part of the chain on a suitable surface (eg, slider-slider, slider-steel, glide bar).

The sliders wear depends on the application. The slider surfaces should be checked at regular intervals. With a thickness of 1-2 mm sliders have to be replaced.

SLE parts 87



SLE link



connector link single



connector link double



connector angle

special material parts like U194 V-0, EX or other have to be named in the order



	R 60, 100, 150, 250											
	galv.	carbur.	Stainl.steel	galv.	carbur.	Stainl.steel	galv.	carbur.	Stainl.steel	galv.	carbur.	stainl.steel
120	0110	-	1806	0104	-	1734	0105	-	1736	0064	-	1732
121	0110	-	1806	0104	-	1734	0105	-	1736	0064	-	1732
128	0110	-	1806	0104	-	1734	0105	-	1736	0064	-	1732
	R 100, 150, 200, 250, 300											
	galv.	carbur.	Stainl.steel	galv.	carbur.	Stainl.steel	galv.	carbur.	Stainl.steel	galv.	carbur.	stainl.steel
220	0117	0821	1739	0115	-	1735	0116	-	1737	0114	-	1733
221	0117	0821	1739	0115	-	1735	0116	-	1737	0114	-	1733
225	0117	0821	1739	0115	-	1735	0116	-	1737	0114	-	1733
228	0117	0821	1739	0115	-	1735	0116	-	1737	0114	-	1733
	R 150, 200, 250, 300, 400											
	galv.	carbur.	Stainl.steel	galv.	carbur.	Stainl.steel	galv.	carbur.	Stainl.steel	galv.	carbur.	stainl.steel
320	1890	1725	1726	0145		1720	0146		1721	0144		1719
321	1890	1725	1726	0145		1720	0146		1721	0144		1719
325	1890	1725	1726	0145		1720	0146		1721	0144		1719
328	1890	1725	1726	0145		1720	0146		1721	0144		1719
	R 200, 250, 300, 400, 500											
	galv.	carbur.	Stainl.steel	galv.	carbur.	Stainl.steel	galv.	carbur.	Stainl.steel	galv.	carbur.	stainl.steel
520	0175		1727 1730	0173		1689	0174		1690	0172		1536
521	0175		1727 1730	0173		1689	0174		1690	0172		1536
525	0175		1727 1730	0173		1689	0174		1690	0172		1536
528	0175		1727 1730	0173		1689	0174		1690	0172		1536
	R 250, 300, 400, 500, 600											
	galv.	carbur.	Stainl.steel	galv.	carbur.	Stainl.steel	galv.	carbur.	Stainl.steel	galv.	carbur.	Stainl.steel
620	1891		-	0877			0876			0884		
621	1891		-	0877			0876			0884		
625	1891		-	0877			0876			0884		
628	1891		-	0877			0876			0884		

Standard-links are produced without band clip cut out. Energy chains with band cover have to be ordered with the following article numbers: SLE 320 0147 , SLE 520 2004 , SLE 620 0878

SLE PART NUMBERS

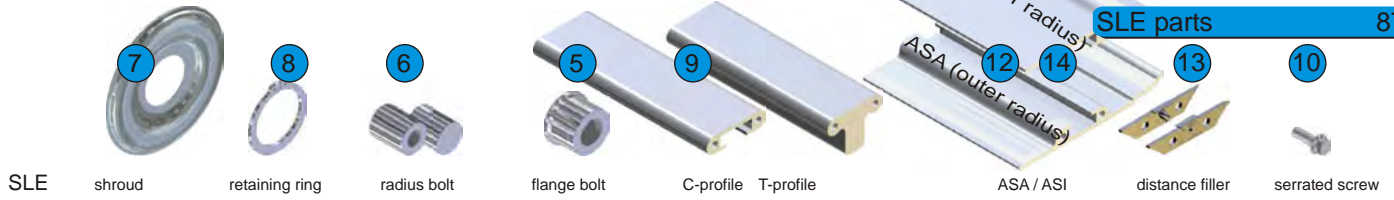

SLE	shroud	retaining ring	radius bolt	flange bolt	C-profile	T-profile	ASA / ASI	distance filler	serrated screw
St	VA	St	CuSn	St	VA		links	rechts	
120	- 1805	0109 -	0106 -	0108 -	0692 -		- -	- -	0127 (M4x12)
121	- 1805	0109 -	0106 -	0108 -	0692 -		- -	- -	0127
128	- 1805	0109 -	0106 -	0108 -	0692 -		- -	- -	0127
220	0119 0137	0118 0136	0120 0121	0122 0134	0124 0141		- -	- -	0127 (M4x12)
221	0119 0137	0118 0136	0120 0121	0122 0134	0124 0141		- -	- -	0127
225	0119 0137	0118 0136	0120 0121	0122 0134	- -		1065 1066	1670 1404	0127
228	0119 0137	0118 0136	0120 0121	0122 0134	0124 0141		- -	- -	0127
320	0149 0166	0148 1247	0150 0151	0152 0165	0154 0171		- -	- -	0157 (M5x14)
321	0149 0166	0148 1247	0150 0151	0152 0165	0154 0171		- -	- -	0157
325	0149 0166	0148 1247	0150 0151	0152 0165	- -		0847 0846	1293 1671	0157
328	0149 0166	0148 1247	0150 0151	0152 0165	0154 0171		- -	- -	0157
520	0177 0193	0176 0192	0178 0179	0180 1529	0182 0194		- -	- -	0185 (M6x18)
6285	0177 0193	0176 0192	0178 0179	0180 1529	0182 0194	515:	0849 0848	1620 1672	0185
525	0177 0193	0176 0192	0178 0179	0180 1529	- -		0849 0848	1405 1673	0185
528	0177 0193	0176 0192	0178 0179	0180 1529	0182 0194		- -	- -	0185
620	0872	0176 0192	- 0874	0180 -	0182 0851		- -	- -	0185 (M6x18)
621	0872	0176 0192	- 0874	0180 -	0182 0851		- -	- -	0185
625	0872	0176 0192	- 0874	0180 -	- -		0957 0956	- -	0185
628	0872	0176 0192	- 0874	0180 -	0182 0851		- -	- -	0185

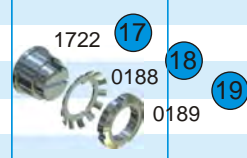

special material parts like UI94 V-0, EX or other have to be named in the order

SLE parts 87



SLE PZ



PTF PT 55 PT 75



LS ZL ZLA8 ZLS10 ZHS10 pipe stay

120	0691		0112			-	-	-		1665	1273	1159	1160	1407	D6 739
121	0691		0112			-	-	-		1665	1273	1159	1160	1407	D6 739
128	0691		0112			-	-	-		1665	1273	1159	1160	1407	D6 739
220	0778	1519	0779	1658		1927	0879	0880		1665	1273	1159	1160	1407	D6 740
221	0778	1519	0779	1658		1927	0879	0880		1665	1273	1159	1160	1407	D6 740
225	0778	1519	0779	1658		1927	0879	0880		1665	1273	1159	1160	1407	D6 740
228	0778	1519	0779	1658		1927	0879	0880		1665	1273	1159	1160	1407	D6 740
320	0163	1678	1659	1660		1927	0879	0880		1665	1273	1159	1160	1407	D8 741
321	0163	1678	1659	1660		1927	0879	0880		1665	1273	1159	1160	1407	D8 741
325	0163	1678	1659	1660		1927	0879	0880		1665	1273	1159	1160	1407	D8 741
328	0163	1678	1659	1660		1927	0879	0880		1665	1273	1159	1160	1407	D8 741
520	0719	1679	1661	1662	1680	1927	0879	0880		1665		1159	1160	1407	D8 742
521	0719	1679	1661	1662	1680	1927	0879	0880		1665		1159	1160	1407	D8 742
525	0719	1679	1661	1662	1680	1927	0879	0880		1665		1159	1160	1407	D8 742
528	0719	1679	1661	1662	1680	1927	0879	0880		1665		1159	1160	1407	D8 742
620	1257	1778	1980	2228	-	-	-	-		-		1159	1160	1407	D8 742
621	1257	1778	1980	2228	-	-	-	-		-		1159	1160	1407	D8 742
625	1257	1778	1980	2228	-	-	-	-		-		1159	1160	1407	D8 742
628	1257	1778	1980	2228	-	-	-	-		-		1159	1160	1407	D8 742

SLE PART NUMBERS

plastic inserts

diameter in mm

SLE 10 15 20 25 30 35 40 45 50 55 60 65 70

120	-	-	-	-	-	-	-	-	-	-	-	-	-
121	-	-	-	-	-	-	-	-	-	-	-	-	-
128	-	-	-	-	-	-	-	-	-	-	-	-	-



220	0649	0650	0651	0652	0653	-	-	-	-	-	-	-	-
221	0649	0650	0651	0652	0653	-	-	-	-	-	-	-	-
225	0649	0650	0651	0652	0653	-	-	-	-	-	-	-	-
228	0649	0650	0651	0652	0653	-	-	-	-	-	-	-	-



320	0654	0655	0656	0657	0658	0659	0660	0661	0662	-	-	-	-
321	0654	0655	0656	0657	0658	0659	0660	0661	0662	-	-	-	-
325	0654	0655	0656	0657	0658	0659	0660	0661	0662	-	-	-	-
328	0654	0655	0656	0657	0658	0659	0660	0661	0662	-	-	-	-















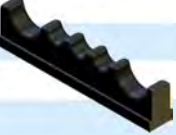
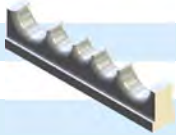



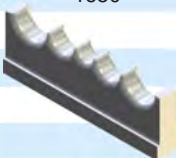
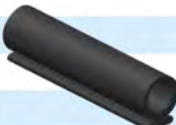

520	1628	0663	0664	0665	0666	0667	0668	0669	0670	0671	0672	0714	0715
521	1628	0663	0664	0665	0666	0667	0668	0669	0670	0671	0672	0714	0715
525	1628	0663	0664	0665	0666	0667	0668	0669	0670	0671	0672	0714	0715
528	1628	0663	0664	0665	0666	0667	0668	0669	0670	0671	0672	0714	0715

620	-	-	-	-	-	-	-	-	-	-	-	-	-
621	-	-	-	-	-	-	-	-	-	-	-	-	-
625	-	-	-	-	-	-	-	-	-	-	-	-	-
628	-	-	-	-	-	-	-	-	-	-	-	-	-

SLE parts 87

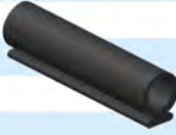
special material parts like UI94 V-0, EX or other have to be named in the order

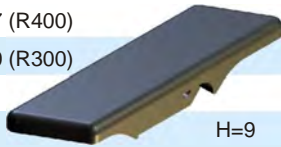

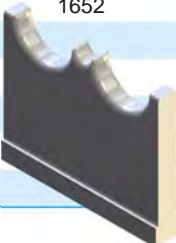
SLE	plastic- insert profile	aluminium insert profile	foam	sliders	flange rollers (complete)
120	-	-	-		
121	-	-	-		
128	-	-	-	1443  H=3,5	
220	0 827	1649	-		0132
221	0 827	1649	-		0132
225	0 827	1649	-		0132
228	0 827	1649	-	1444  <R200 H=7,5	-
				1970  ≥ R200	
320	1646	1650	2365	1445 	0162
321	1646	1650	2365	1448  H=9,5	0162
325	1646	1650	2365		0162
328	1646	1650	2365	1955  (Standard)	1968  0162
					
520	1647	1651	2365		0190
521	1647	1651	2365		0190
525	1647	1651	2365	1446  H=9	0190
528	1647	1651	2365	1987  H=15	-
					
620	1648	1652	-		0190
621	1648	1652	-	1447 (R400) 	0190
6290	1648	1652	-	2070 (R300)	
628	1648	1652	-	H=9	
					

SLE PART NUMBERS

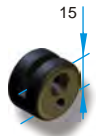

SLE damping element



screw nut



double bolt
St vz VA



glide disc



SLE parts 87

				D45 d13				D55 d15		D70 d20	
120				0694				0693 0969 (compl.)			
121				0694				0693 0969 (compl.)			
128				0694				0693 0969 (compl.)			
								D80 d19		D95 d25	
220	2136	0826	0825	0123	0138			0128 0963 (compl.)		0129 0964 (compl.)	
221	2136	0826	0825	0123	0138			0128 0963 (compl.)		0129 0964 (compl.)	
225	2136	0826	0825	0123	0138			0128 0963 (compl.)		0129 0964 (compl.)	
228	2136	0826	0825	0123	0138			0128 0963 (compl.)		0129 0964 (compl.)	
								D105 d25		D120 d30	
320	0819	2136	0826	0825	0153	1718		0158 0965 (compl.)		0159 0966 (compl.)	
321	0819	2136	0826	0825	0153	1718		0158 0965 (compl.)		0159 0966 (compl.)	
325	-	2136	0826	0825	0153	1718		0158 0965 (compl.)		0159 0966 (compl.)	
328	0819	2136	0826	0825	0153	1718		0158 0965 (compl.)		0159 0966 (compl.)	
								D155		D170	
520	2025	2136			0181			0186 0967 (compl.)		0187 0968 1575 (br.)	
521	2025	2136			0181			0186 0967 (compl.)		0187 0968 1575 (br.)	
525	-	2136			0181			0186 0967 (compl.)		0187 0968 1575 (br.)	
528	2025	2136			0181			0186 0967 (compl.)		0187 0968 1575 (br.)	
								d30		d30	
620	2025	2136						1538		1539	
621	2025	2136						1538		1539	
625	1999/2000							1538		1539	
628	2025	2136						1538		1539	

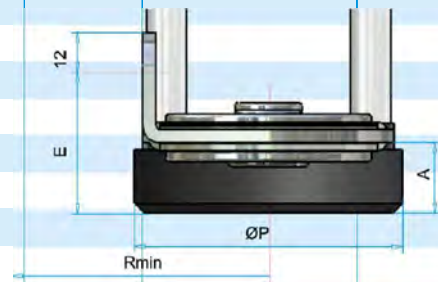
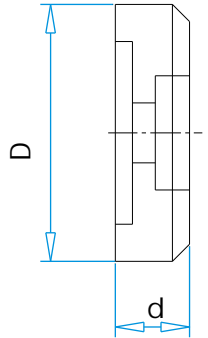

	A	E	ØP	Rmin
SLE 220	20	36,5	70	40
	15	31,5	55	
SLE 320	25	48	95	52,5
	19	42	80	
SLE 520	30	61	120	65
	25	55	105	



Support brackets and support rollers

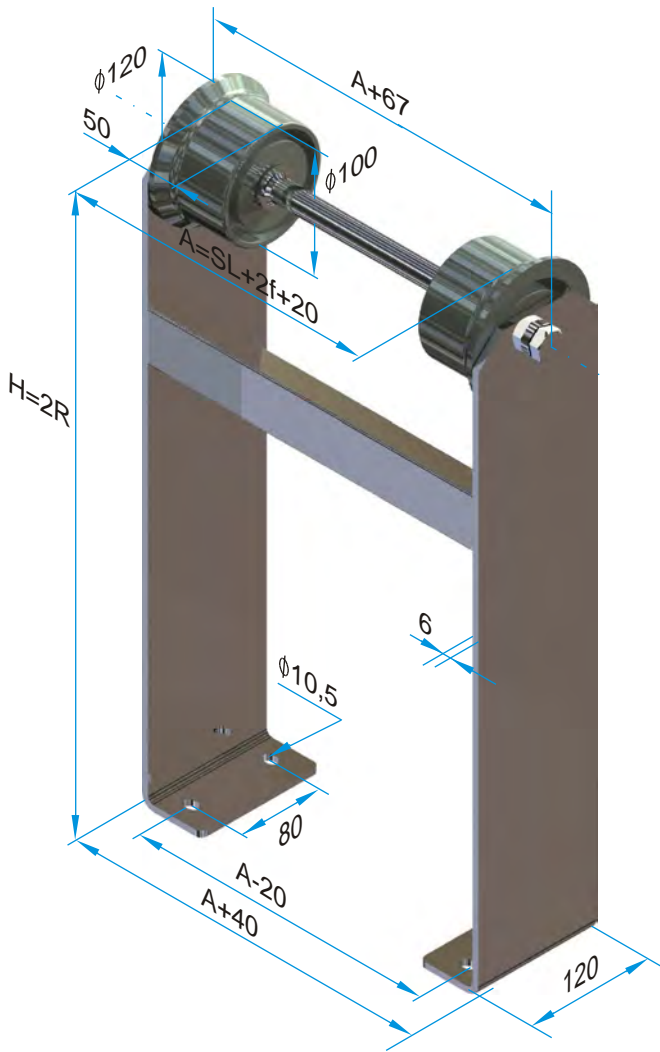

Support rollers are used when half of the travel exceeds the free carrying length ($L_v > 2LF$).

Support rollers allow four times extension of travel distance (see design guidelines).

The order of support rollers SR with support brackets for SLE (roller $\phi 100$ for all sizes) contains the following information:

SR width of support [cm] / $\phi 100$ x height of bracket

The **width of the support (A)** depends on the width of the energy chain:

The dimension A is to be calculated with the chain outer width in mm and round up to cm:

$$A = \text{staylength} + 2f + 20$$

The height (H) of the support depends on the bending radius of the used energy chain: $H = 2R - \text{max. } 5\text{mm}$

For example: SLE 320 dim. $f=11$, bend radius 200 mm stay length 215 mm:

$$215 + 2 \times 11 + 20 = 257 \Rightarrow A = 26$$

SR 26 / $\phi 100$ x 400

The steel support rollers are delivered with robust high-quality support frames.

The height of the moved connector must be adjusted with a maximum 5mm distance from the base of the supporting roll.

As an alternative to steel rollers SR, plastic support rollers PR for plastic chains are available.

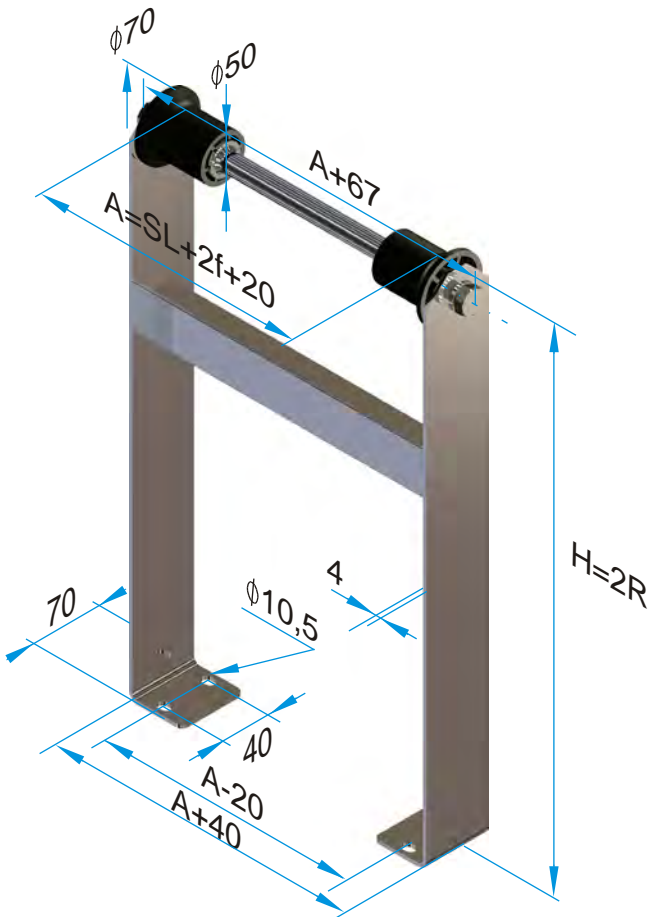

Flange rollers

The flange rollers are used for very long chains in combination with a support railing with supporting rollers and support frames (see design guidelines).

Guide rollers for steel chains

Guide rollers are used for steel chains in arrangement u (moving end downside, see arrangements). In this case provide a trough or a corresponding support rail.

	v
SL 220	44
SL 320	46
SL 520	50
SL 620	50

Gliding discs for steel chains

For the SLE in arrangement w (lying horizontally on the side) for the longest travel distance or in arrangement k (circular) gliding discs are used. The gliding discs are made of high quality, highly abrasion-resistant materials. In both arrangements a guide is necessary.

Shelf troughs for steel chains

Shelf troughs consist of two standard angular channels that are welded together from 3m lengths. Shelf troughs will be used if a smooth and precise guidance of steel chains is necessary.

Important for the assembly: Weld angular channels smooth and without any offset and clean the weld seams. In the entire shelf area no projections or obstructions may be present (eg, screw heads, nuts,).

Support carriage for steel chains

Steel chains with support carriage are used for long travel distances and very high additional weights in a counter-chain arrangement. With side-mounted guide rollers the energy chains are supported on the support carriage.

Technical Features: No push - just pull-tension, large travel distances, extreme additional loads, smooth running, long life.

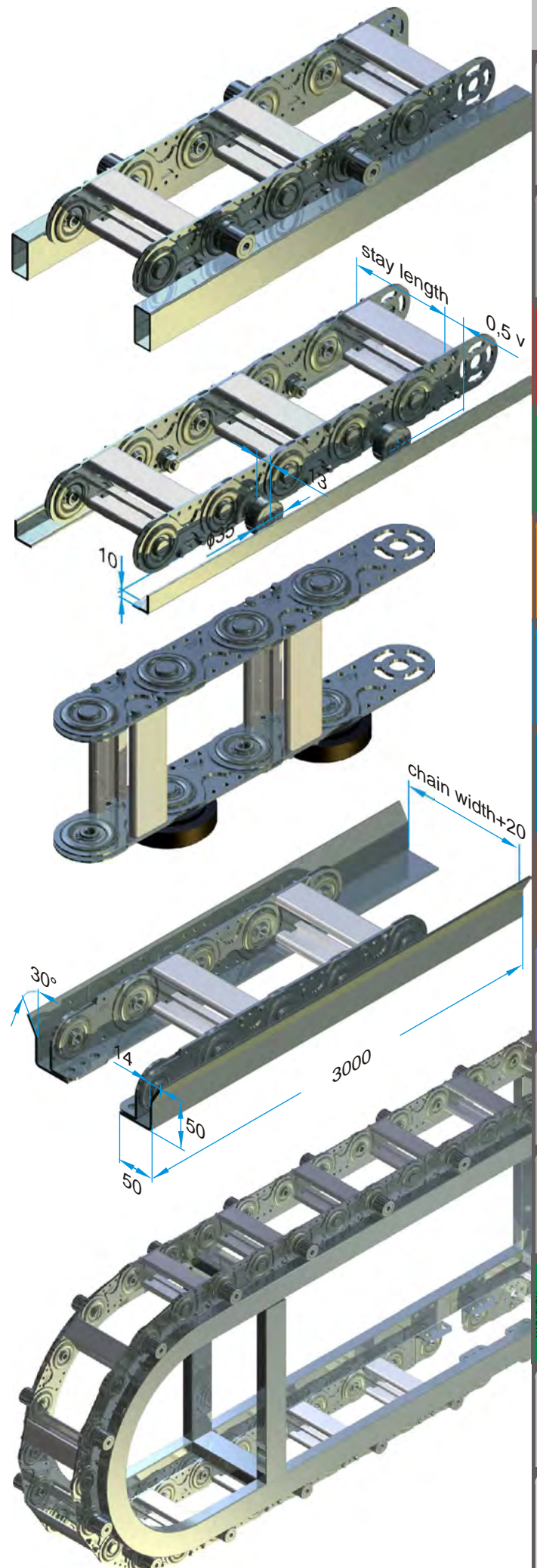

GKA

- GKA dimensions 102
- GKA connectors 103
- GKA types 103
- GKA sizes 104
- GKA parts 105

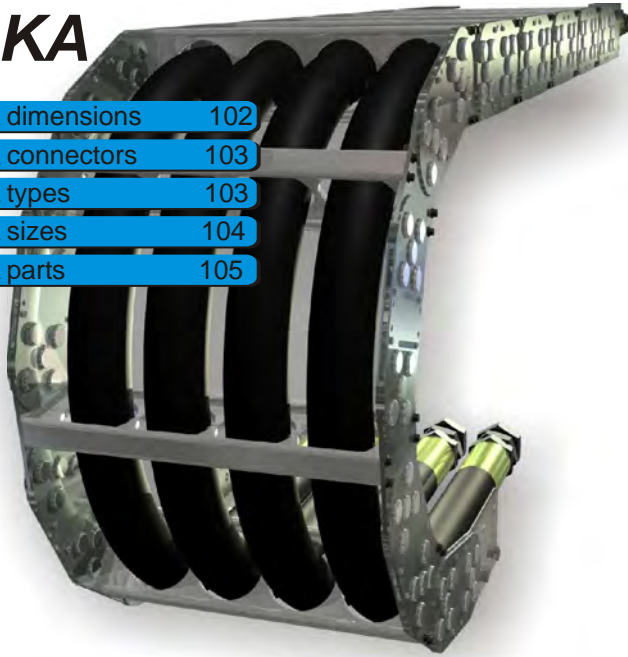

GKA characteristics

The GKA is characterized by the highest stability compared to standard chains, with almost unlimited dimensions and the choice of material.

The interior is custom formed and thus guarantees an optimal cable guiding.

Stay lengths up to 1200 mm are possible.

The bending radius can be created according to customer specifications if required.

Dimensions

bend radius:	200	to	...	mm
inner height:	118	to	468	mm
inner width:	100	to	1172	mm
energy chain weight:	25	to	85	kg/m

Travel

The maximum travel distance is determined by the arrangement and the additional weight (line weight). At normal arrangement maximum travel is double the chain length minus the arc of the chain radius. Support rollers or similar constructive steps can increase this value.

Travel speed

The standard and the stainless steel type are limited at 1 m / s. Exceeding this and high dynamic loads caused by eg vibrations need the use of carburated material.

Acceleration

The acceleration in principle is not limited. However limits may exist if very long chains and line weights cause extreme tensile forces.

Service temperature

The operating temperature is -20 ° C up to 600 ° C (stainless steel -40 ° C up to 600 ° C).

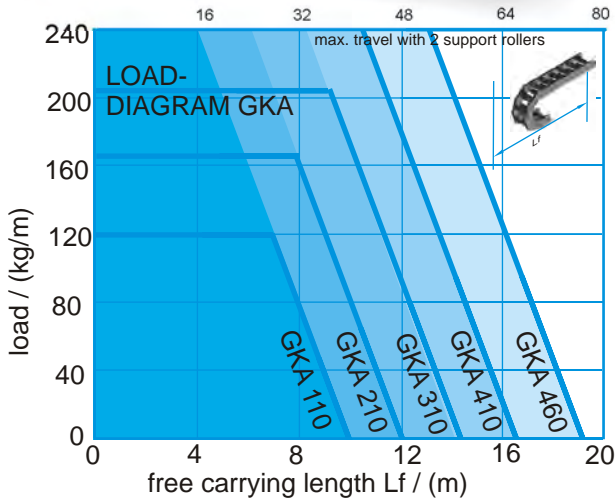

application range

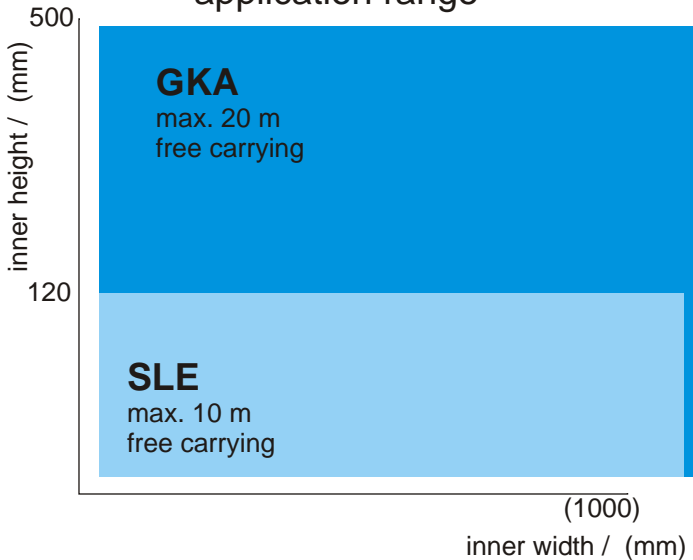

GKA with aluminum profile

A highly customized and robust design that is used mainly in larger steel chains. The stays are created according to the specifications of the user:



GKR with rods

Made of stainless steel this energy chain is generally offered for off-shore, since aluminum is not suitable for these applications. The chains can be separated into different sections by additional stainless steel dividers:



GKP with plastic dividers

These stays can be especially used for heavy mechanical engineering. The advantages in comparison to the GKA (aluminum profile) are in the price, the weight and space savings.

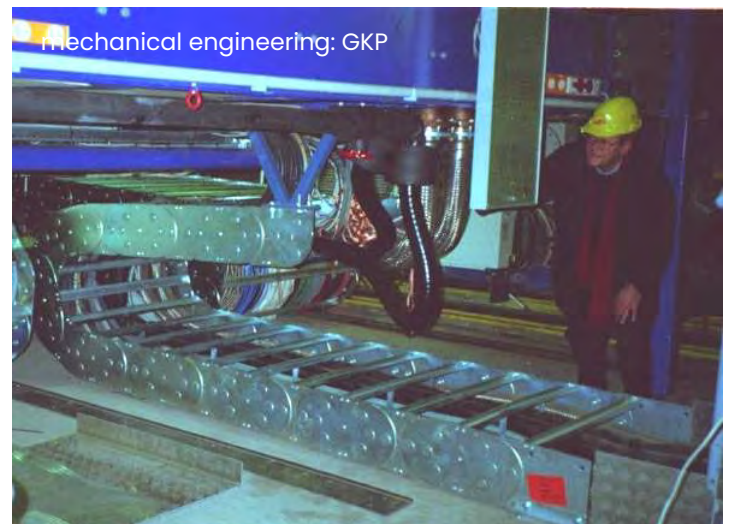

Design guidelines
Order infos
Kollibri
PKK
PLP PLA
PLE PLE PLA
SLP SLA
SLE
GKA
SFK
PFR
Troughs
Systems
Materials
Informations

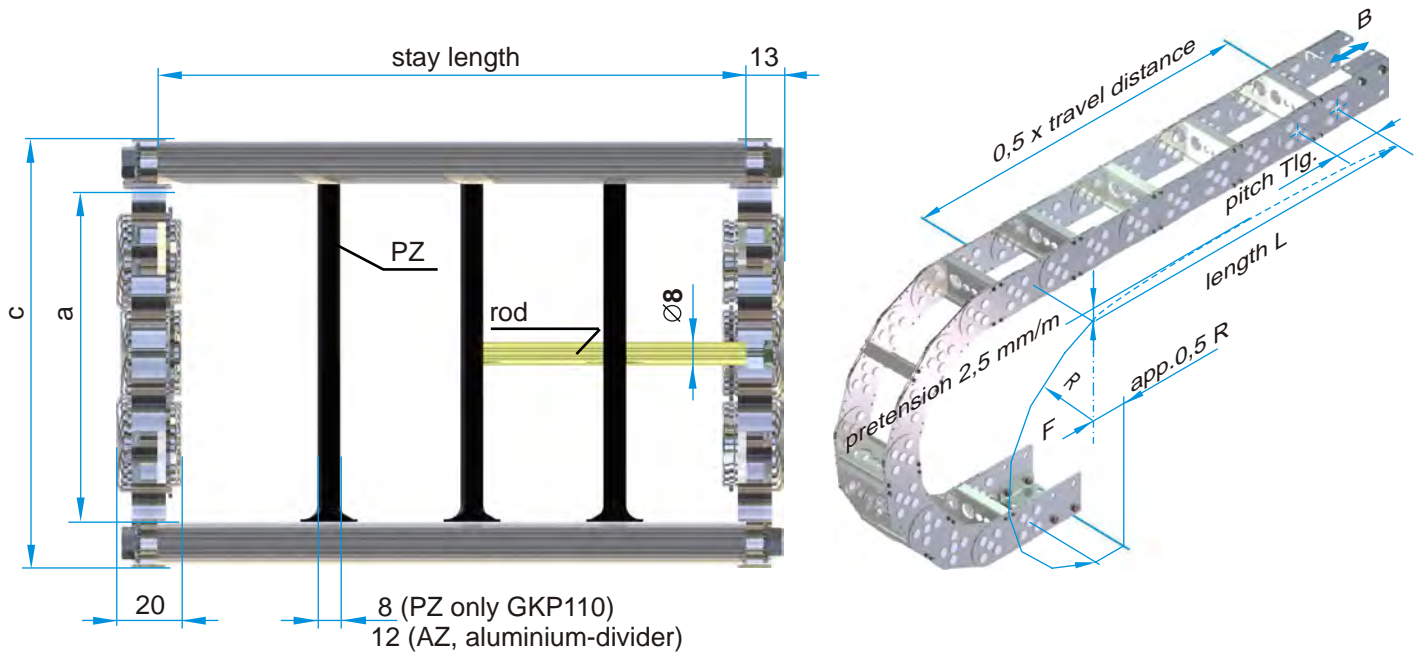

GKA	bending radius	Tlg. pitch	a	c	o	p	weight ¹⁾ kg/m
110	as specified (>200)	175	118	150	230	110	25
160	as specified (>250)	225	168	200	300	160	30
210	as specified (>300)	275	218	250	370	210	40
260	as specified (>400)	325	268	300	430	260	45
310	as specified (>450)	375	318	350	500	310	55
360	as specified (>550)	425	368	400	560	360	65
410	as specified (>600)	475	418	450	620	410	75
460	as specified (>700)	525	468	500	680	460	85

¹⁾weight for stay length 500

The bending radius is freely chosen after consultation. It is advantageous to adjust the bending radius of the chain to achieve a minimal polygon effect.

Stay lengths are available in steps of 1 mm.

The usable interior width is stay length minus 14 mm

Stay types and connectors may vary from those representations. Energy chains GKA are custom made in consultation with the client, usually from drawing. Item numbers are not given for this reason.

For energy chains type GKA choose the order length as an uneven multiple of the pitch.

order example: max. travel distance 20,9 m, bend radius 800 mm, normal constellation

GKA 460 / 800	x	14175	/ 1000	/ N/N	acc. drawing
type / radius	x	length	/staylength	/ connectors	

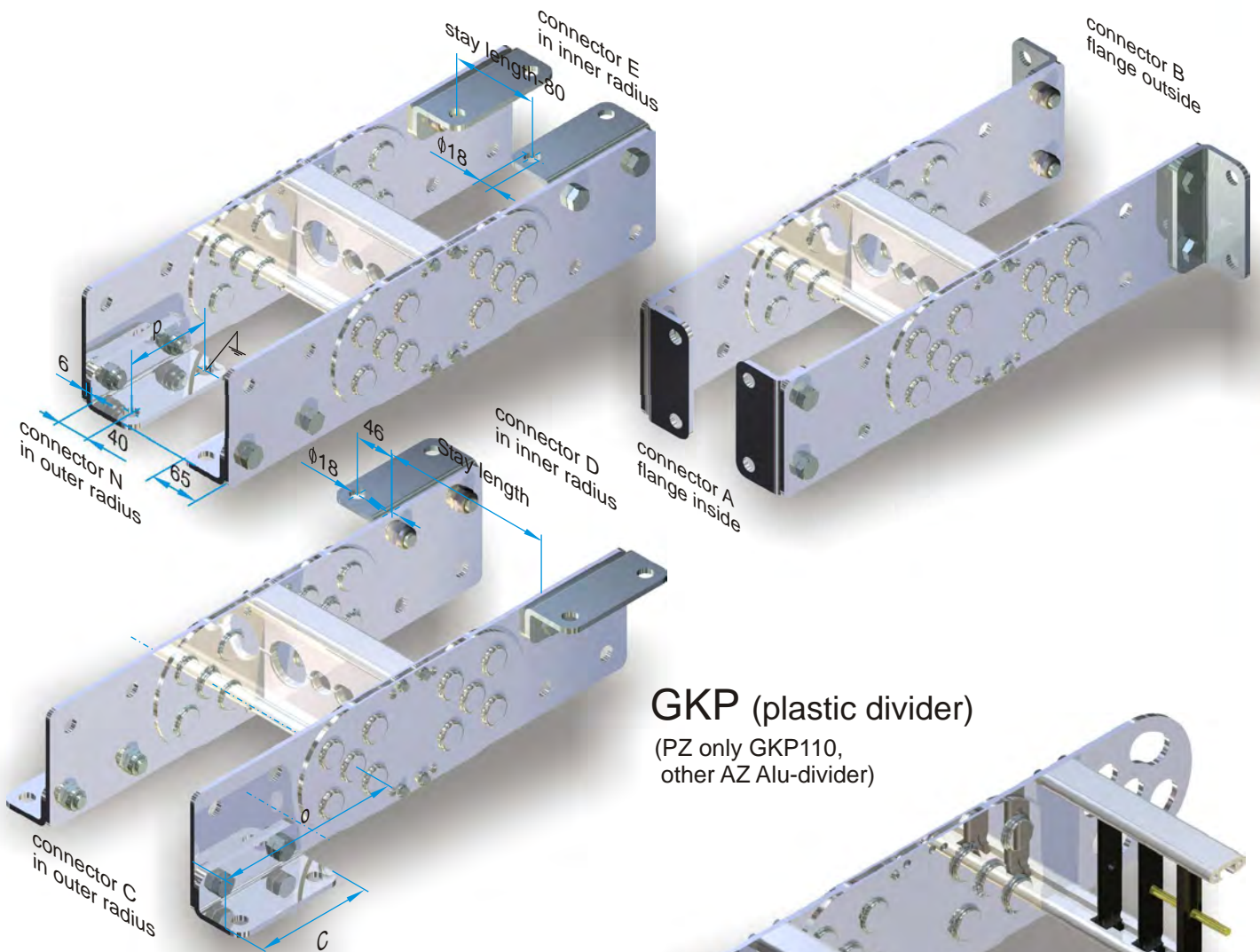

GKP (plastic divider)
(PZ only GKP110,
other AZ Alu-divider)

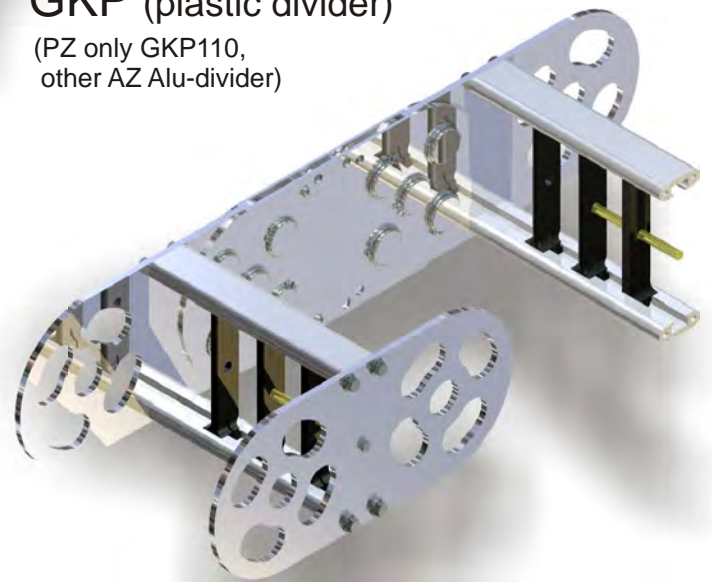

GKA (aluminium stays)

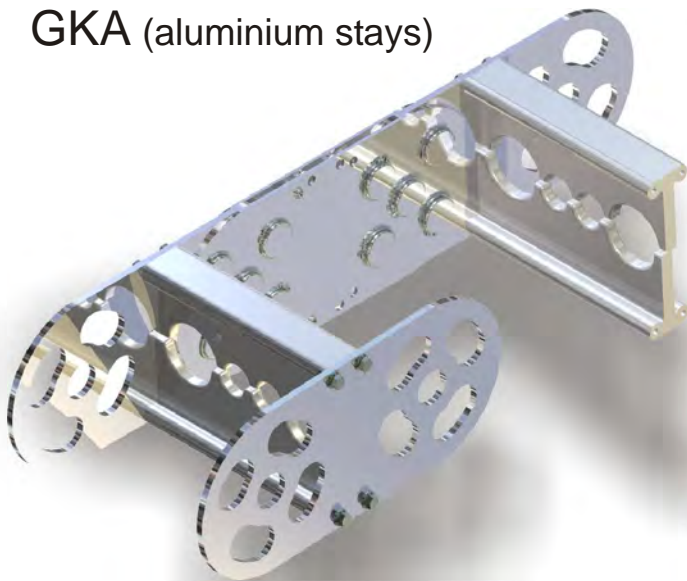

GKR (rods)

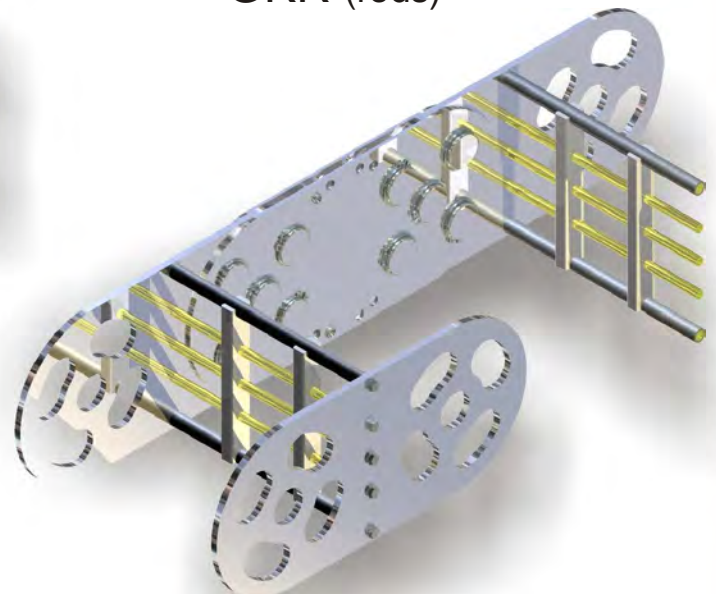

Content
Design guidelines
Order infos
Kollibri
PKK
PLE P/LP PLA
SLP SLA
SLE
GKA
SFK
PFR
Troughs
Systems
Materials
Informations

GKA sizes

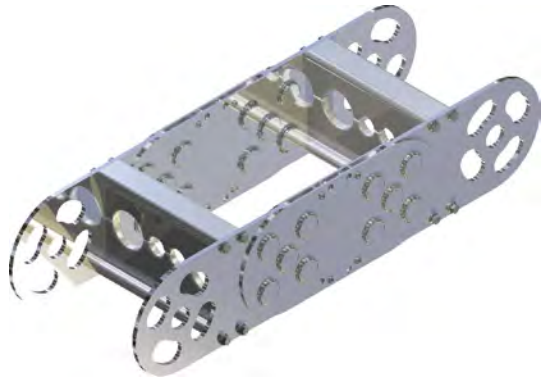

GKA 110

height 150 ,width and bending radius as specified

GKA 160

height 200 ,width and bending radius as specified

GKA 210

height 250 ,width and bending radius as specified

GKA 260

height 300 ,width and bending radius as specified

GKA 310

height 350 ,width and bending radius as specified

GKA 360

height 400 , width and bending radius as specified

GKA 410

height 450 ,width and bending radius as specified

GKA 460

height 500 ,width and bending radius as specified

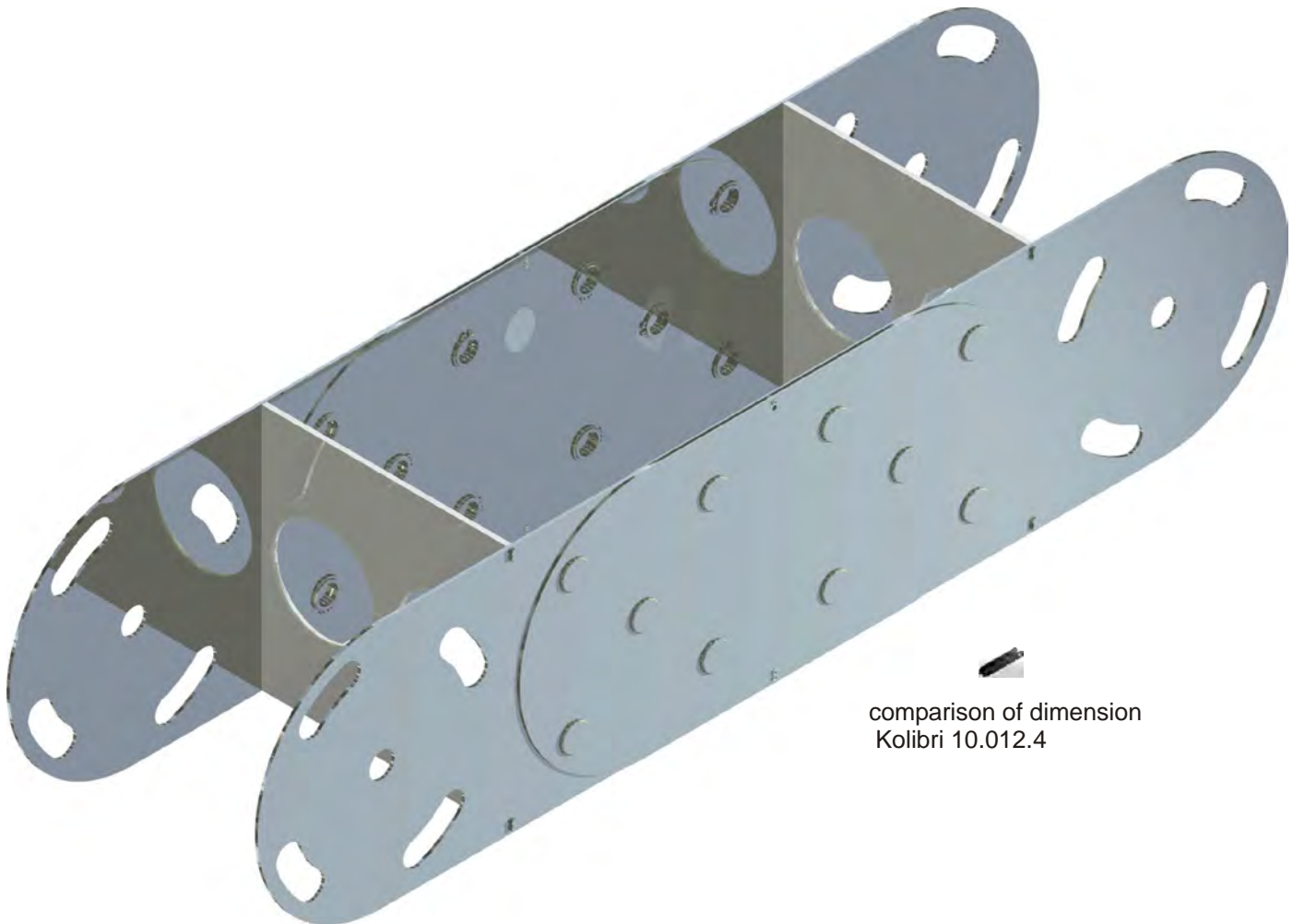
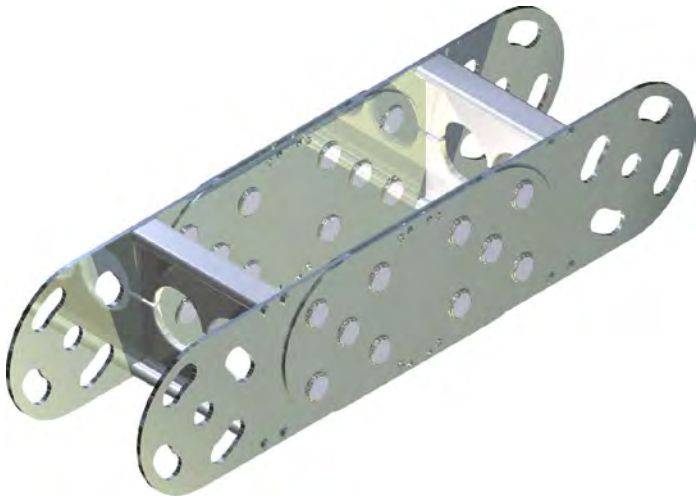

comparison of dimension
Kolibri 10.012.4

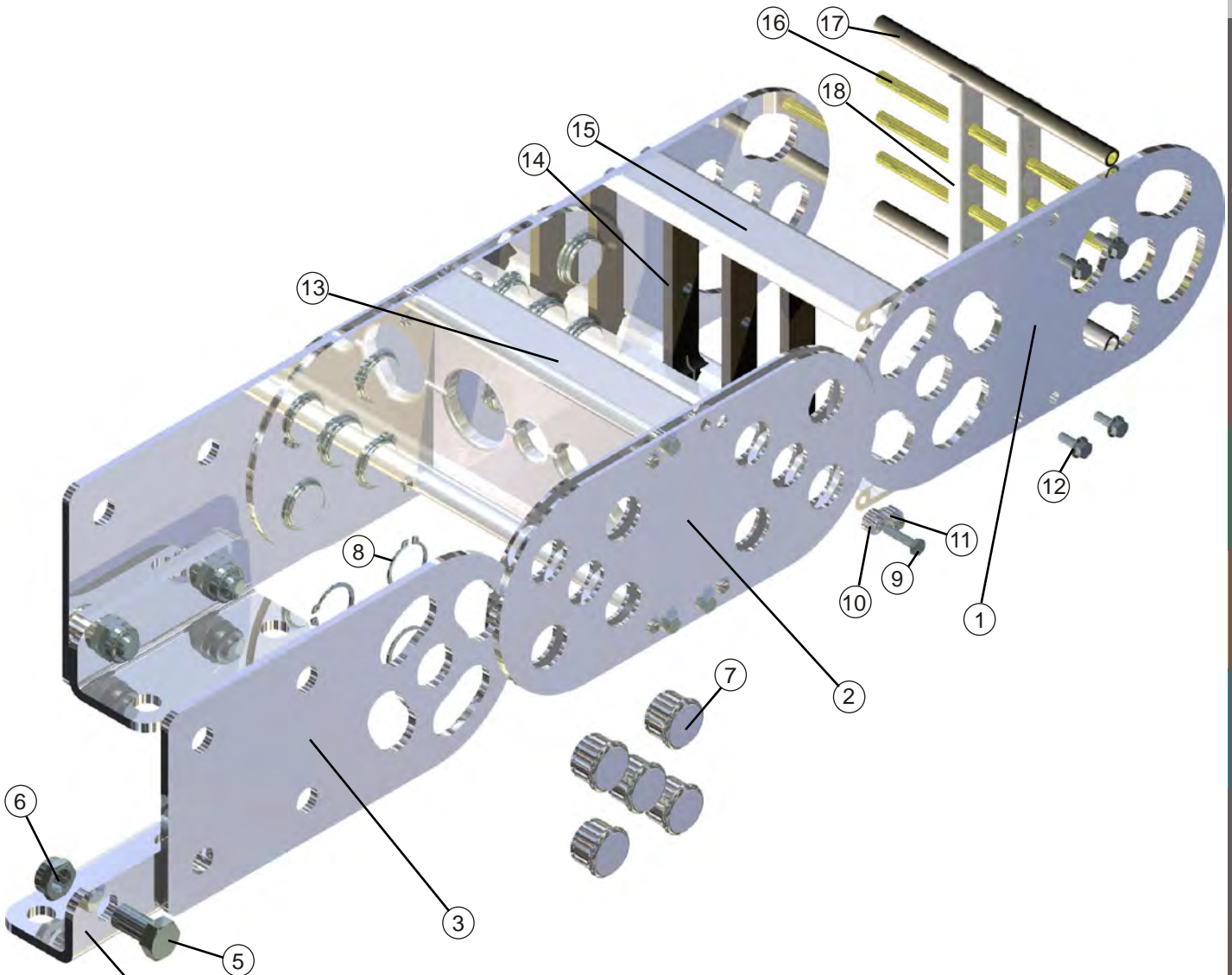

item	name
1	link with slot
2	link with drilling
3	connector links
4	connector angle
5	screw M16 x 25
6	nut M16 (self locking)
7	flange bolt
8	retaining ring A30
9	screw M6 x 25
10	distance filler
11	rivet bushing
12	serrated screw M6 x16
13	aluminum T-profile GKA
14	plastic divider (PZ)
15	aluminum C-profile GKA
16	rod
17	roller stay
18	aluminum divider

SFK

SFK dimensions 106

SFK connectors 107

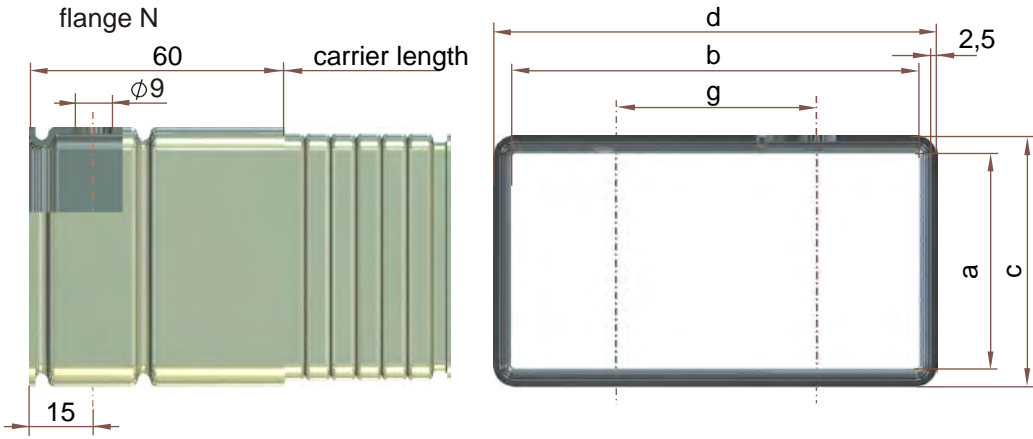

SFK	radius	a	b	c	d	g	k	p	z	weight kg/m
22 N	100 / 150	40	79	45	85	50	30,5	71	65	3.0
22 H	150 / 200	56	80	60	85	50	30,5	86	90	3.5
22 S	200	78	78	85	85	50	30,5	111	130	5.1
32 N	150 / 200	54	109	60	115	80	30,5	86	90	4.8
32 H	200 / 250	75	110	80	115	80	30,5	106	120	5.3
32 S	300	109	109	115	115	80	30,5	141	175	6.6

The order of length is equal to half the length of travel, plus four times bending radius:

$$L = L_v / 2 + 4 R$$

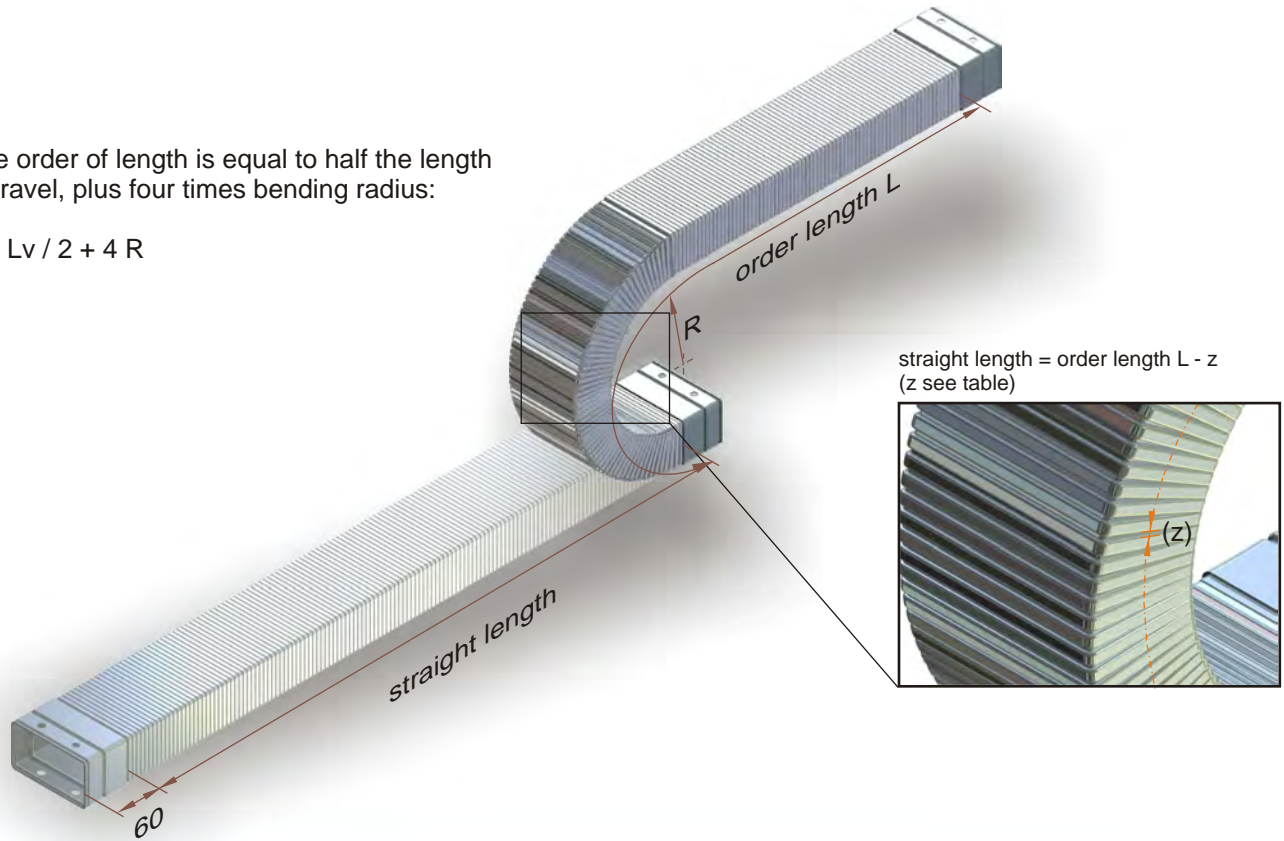

order example: max. travel distance 3 m, bending radius 100 mm, standard arrangement

SFK 32N / 200	x	1900	/	N/N
type / radius	x	length	/	connectors / arrangement

SFK Characteristics

The chain consists of a rectangular, galvanized steel spiral band and mounted in inner radius is a spring steel band. The SFK offers large usable cross-sections at low external dimensions and optimum line protection. At low cantilever lengths the SFK is ideal for areas with hot chips and sparks.

The temperature range is between -40 ° and +180 ° C.

SFK Flanges

Flange N

Standard is the low priced flange N, each with four mounting holes.

order example

SFK 32N	/ 250	x	3000	/ NN	/ h
type	/ radius	x	length	/ flange	/ arrangement

Flange A

With countersunk screws, knurled nuts and angles the standard flange N changes to flange A.

order example

SFK 32N	/ 250	x	3000	/ AA	/ h
type	/ radius	x	length	/ flange	/ arrangement

Flange B

Flange B is connected laterally with angles. The holes of standard flanges N are omitted.

order example

SFK 32N	/ 250	x	3000	/ BB	/ h
type	/ radius	x	length	/ flange	/ arrangement

Scoop mount

Scoop mount complements the diversity of the possible connector types.

order example

SFK 32N	/ 250	x	3000	/ S1	/ h
type	/ radius	x	length	/ flange	/ arrangement

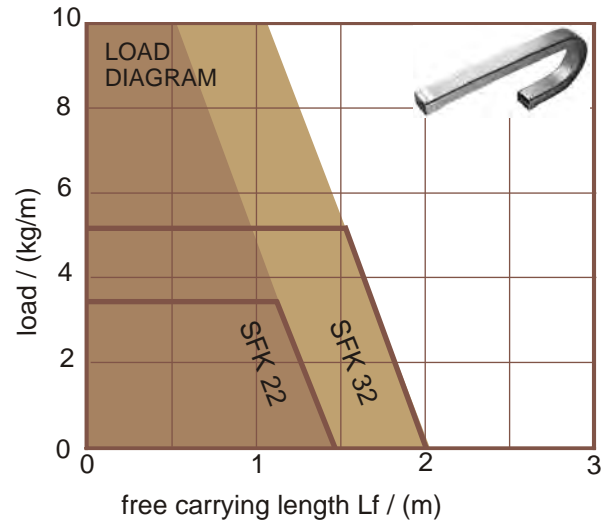
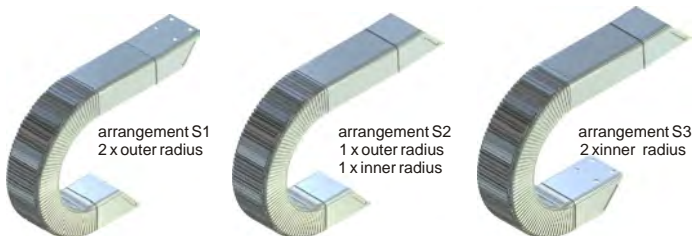

flange N

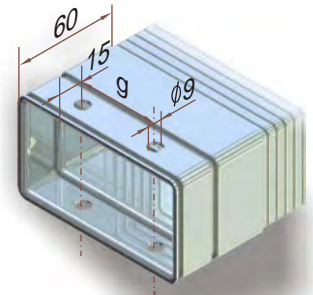

flange A

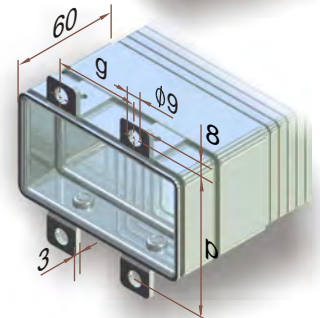

flange B

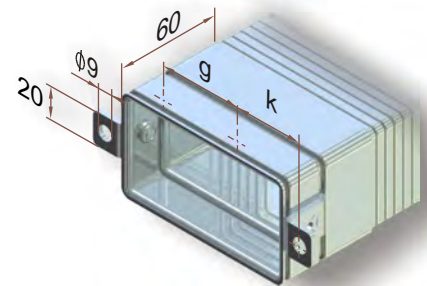

scoop bracket

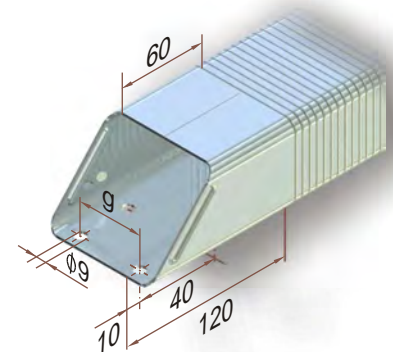

PFR

PFR dimensions 108

PFR connectors 109

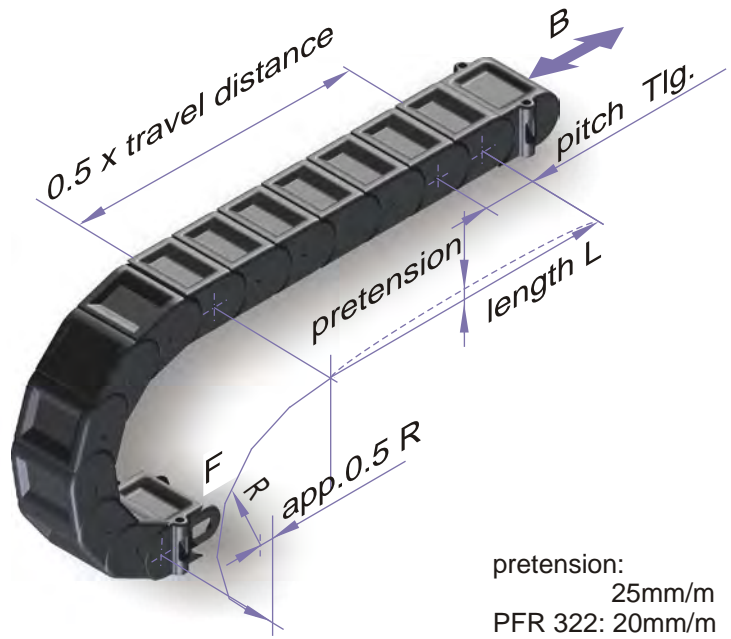
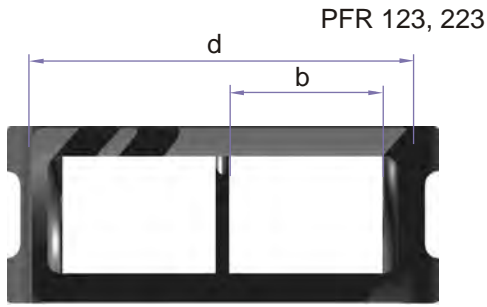
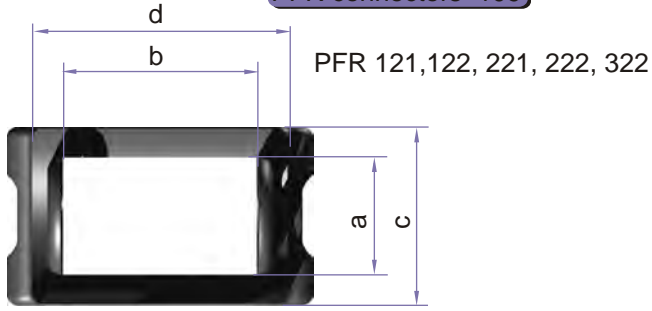

pretension:
25mm/m
PFR 322: 20mm/m

PFR	radius	pitch	a	b	c	d	f	g	h	i	k	k _N	p	p _N	w	weight kg/m
121	75 / 150	35	23	23	35	35	6	0	5,1	9	5,5	61	25	61	20	0,7
122	75 / 150	35	23	38	35	50	6	20	5,1	9	5,5	56	25	61	20	1,2
123	75 / 150	35	23	30	35	75	6	45	5,1	9	5,5	56	25	61	20	1,5
221	100 / 200	50	34	36	50	50	8	20	6,1	11,5	5,5	56	40	76	25	1,6
222	100 / 200	50	34	86	50	100	8	70	6,1	11,5	5,5	56	40	76	25	2,1
223	100 / 200	50	34	66	50	150	8	120	6,1	11,5	5,5	56	40	76	25	2,8
322	150 / 300	65	57	134	75	150	10	120	8,1	15	5,5	56	65	101	35	3,2

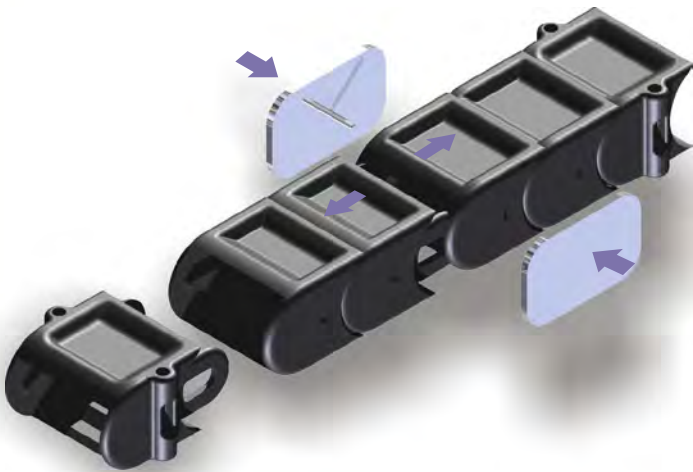

Dismantling PFR

The pins (3x12mm) of the dismantling tools are inserted into the provided openings, dismantling tools compress and pull apart the carrier.

order example: travel 3 m, bend radius 200 mm, plastic connectors, arrangement hanging

PFR 222 / 200 x 2300 / K K / h
type / radius x length / connectors / arrangement

PFR characteristics

The plastic tube PFR is a closed design with excellent protection from dirt and damage caused by chips or the like. In the types PFR 123, 223 and 323 the cables are kept in two separate chambers.

PFR with metallic finish is a ekd specialty that mainly occurs in applications with hot chips and sparks. Due to the high surface temperature conductivity and scratch resistance there are no limits for this surface coating. In addition this type has an exceptionally high quality look with the shiny metallic surface.

PFR with metallic surface are deliverable only on request.

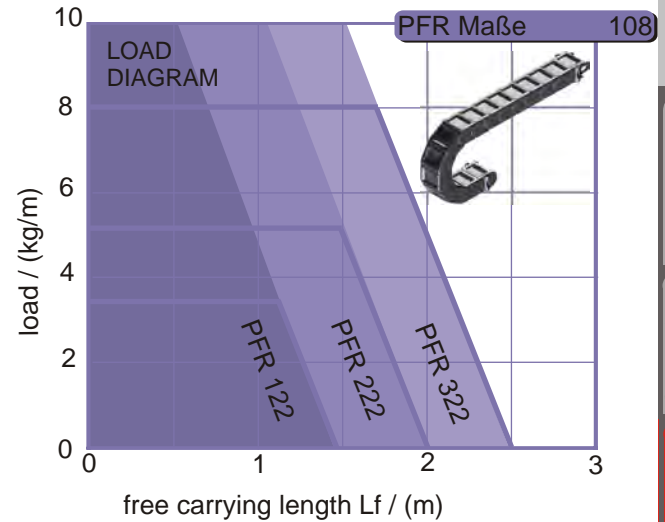

Plastic connector PFR

The plastic end connector can be installed at any point in the chain, whereby a portion of the tube can serve as a static line.

Order example: plastic connector on both sides

PFR 121	/ 75 x 1505	/ KK
type	/ radius x length	/ connectors

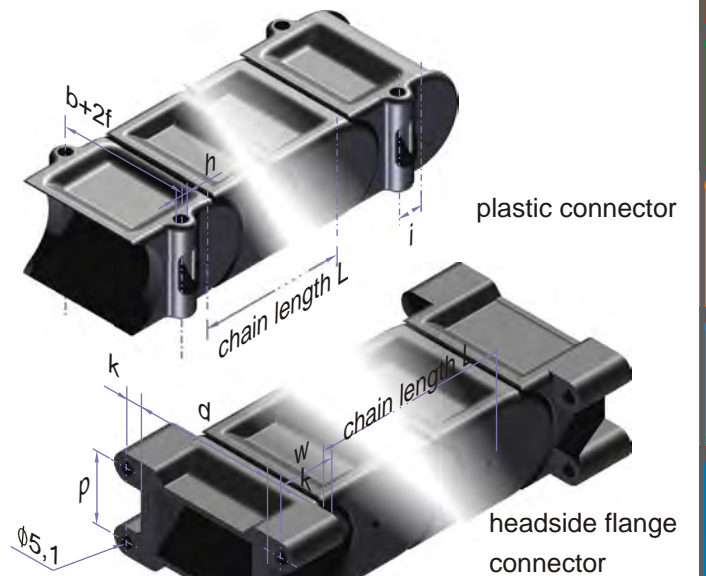

Headside flange connector PFR

The headside bracket is used for assembly on top or front of the machine. A combination of frontal and end connection is possible.

Order example: plastic connector and headside flange

PFR 121	/ 75 x 1505	/ KSFA
type	/ radius x length	/ connectors

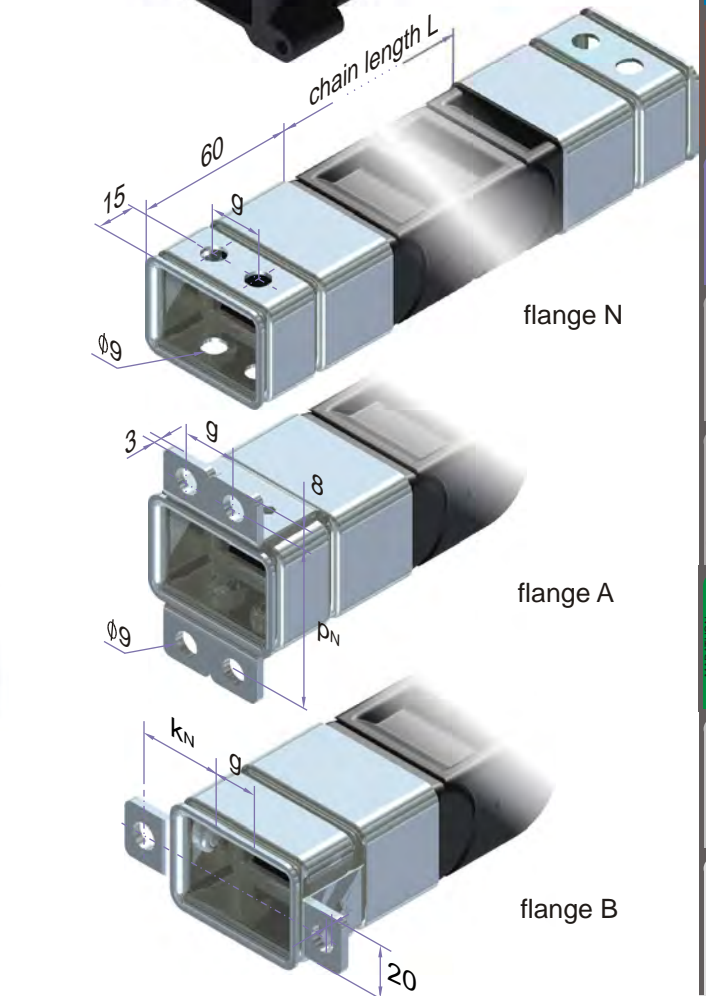

Normal flange (steel) brackets

Normal flanges made of steel can be supplied on request.

Ordering example: N flange and flange A

PFR 121	/ 75 x 1505	/ NA
type	/ radius x length	/ connectors

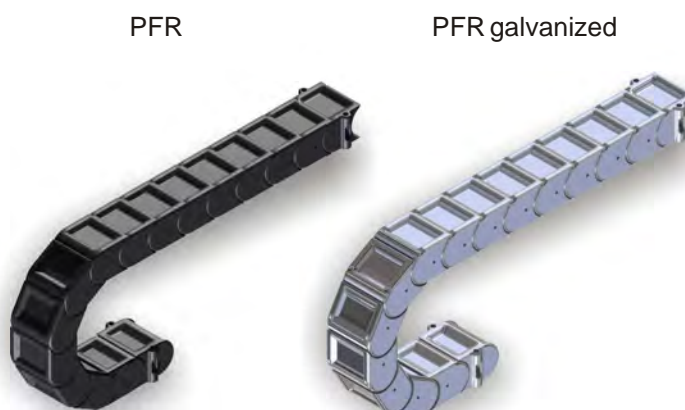

Guide troughs are necessary when a suitable surface for the unrolling of the energy chain is not present and to give guidance and support throughout the chain length.

gliding arrangement

The designing and assembling of the filing and guide channels should be handled with great care, because this is the only chance for a smooth operation of the system. ekd gelenkrohr manufactures troughs for all applications made of steel (galvanized), stainless steel or aluminum. The individual channel segments are mounted with connecting elements.

Trough for steel chains

Troughs for steel chains are made of edged groove angles that are bolted directly on the floor or on the corresponding substructures.

Steel-trough

The steel-trough is universally applicable. Besides the standard channel steel troughs (galvanized). Special dimensions and stainless steel guide troughs are available.

A simple on-site assembly is guaranteed by the top-hat profiles on which the trough segments can be accurately aligned. For this first preassembly the connection angle is finger tight then screw on the angles with the welded inserts. Then the groove is aligned and the connection angle can be fixed.

For gliding applications the angles are supplied with mounted slide bars.

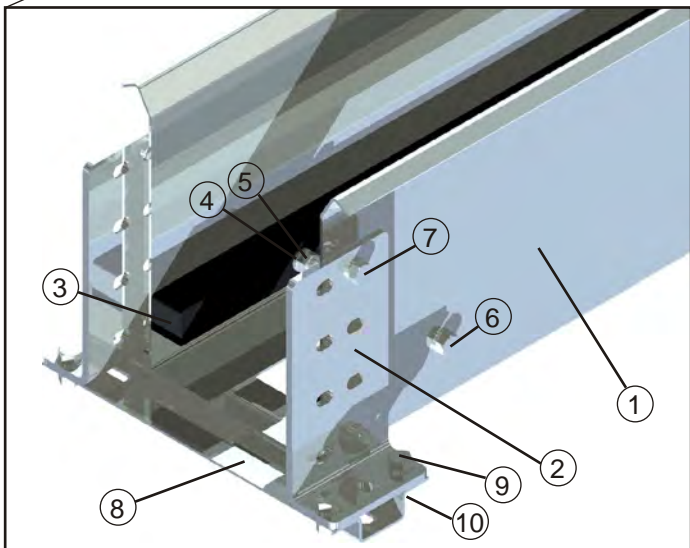
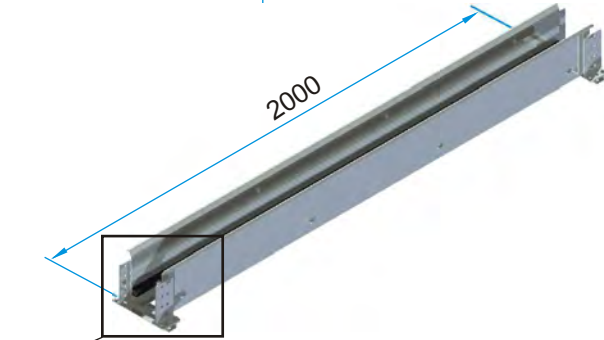
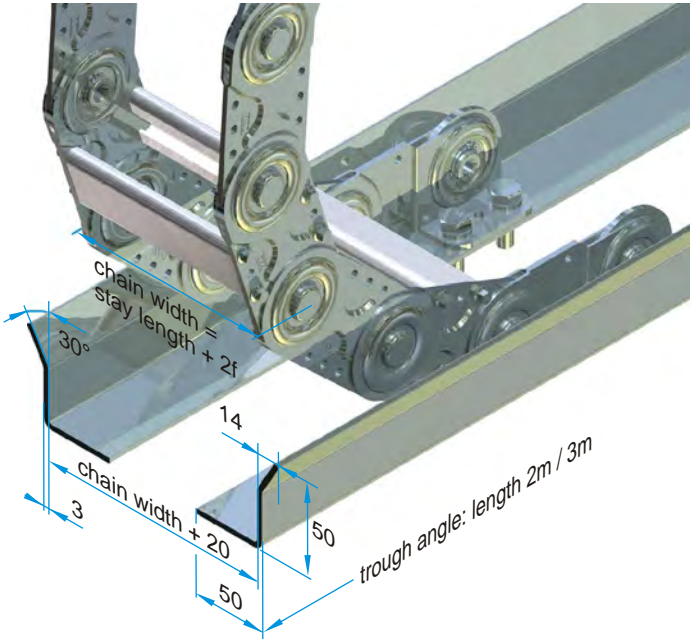

item	name	weight [kg/m]		
		height 2mm	3mm	
1	trough angle 2mm ¹⁾			
2	connection angle ²⁾	100	4.1	5.5
3	slide bar 25x25x2000			
4	washer DIN 125	150	5.3	7.2
5	nut M8 DIN 985			
6	DIN 931 M8x40	200	6.5	8.8
7	DIN 933 M8x12			
8	hat profile	250	7.7	10.4
9	DIN 931 M8x16			(weight incl. slide bar)
10	nut M8			(slide bar 25x25 0.6kg/m)

1) standard heights 100 / 150 / 200/250, L=2000mm, alternative L=3000mm, t= 3 mm
 2) connection angles 40 / 80 / 120 / 160 / 200
 3m standard height 200

Aluminum trough

The aluminum trough (trough height 120mm) is perfectly adapted to floor assembly for long travels with energy chains of the type Kolibri.

Constructed with 3 m long channel segments, the width corresponds to the chain size, a fast and easy installation is performed. The connection of the single channel segments is with center bolts.

The first half of travel is fitted with gliding bars so that a smooth transition at the fixed connector (usually mid-travel) is guaranteed.

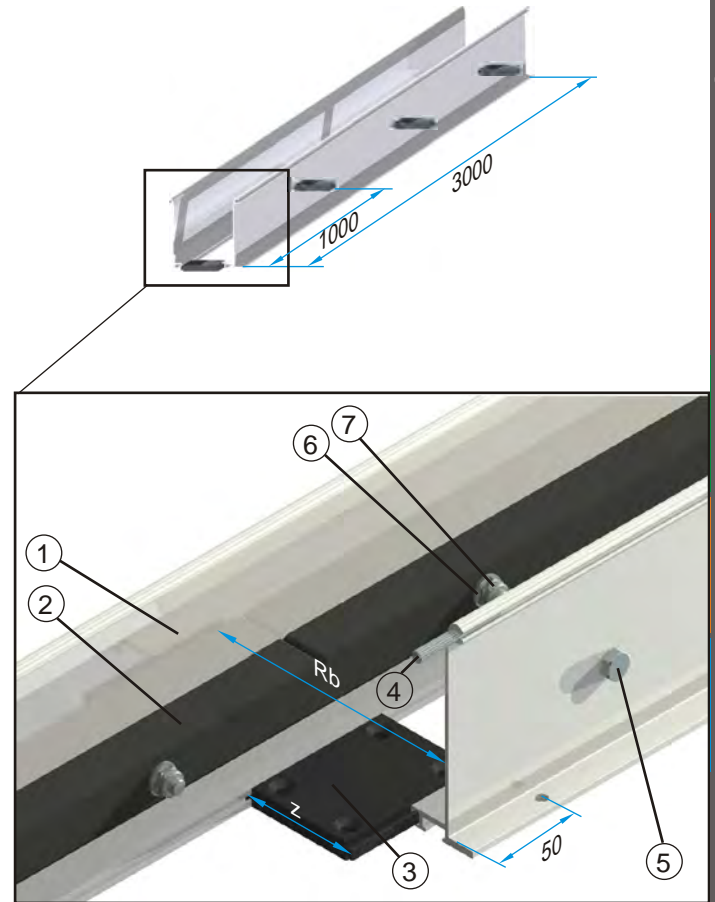

item	name	part no.	weight [kg]
	aluminium tough	1361	
1	alu-trough angle 120x3000	-	3.5
2	slide bar 20x20x3000	1606	1.2
3	distance profile DP (s.b.)	(s.b.)	(s.b.)
4	groov. pin DIN1474 6x40	-	0.008
5	screw DIN 931 M6 x 35	-	0.010
6	washer DIN 125 - 1 A6	-	0.001
7	nut DIN 987 M6	-	0.004

distance profiles for aluminium troughs						
Rb	name	part no.	energy chain ¹⁾	c x d ²⁾	z	[kg]
54	DP 54	1367	Kolibri 30.050.X	30 x 50	20	0.017
64	DP 64	1551	Kolibri 30.060.X	30 x 60	30	0.020
66	DP 66	1368	Kolibri 40.062.X	40 x 62	32	0.022
70	DP 70	1552	Kolibri 50.065.X	50 x 65	36	0.026
80	DP 80	1553	Kolibri 40.075.X	40 x 75	46	0.037
84	DP 84	1554	Kolibri 30.080.X	30 x 80	50	0.042
100	DP100	1369	Kolibri XX.095.X	30 x 95, 50 x 95	66	0.059
130	DP130	1555	Kolibri XX.125.X	30 / 40 / 50 x 125	96	0.092
154	DP154	1556	Kolibri 50.150.X	50 x 150	120	0.118
116	DP116	1557	PKK 210 stay 90	50 x 110	82	0.076
160	DP160		PKK 228 stay 120	55 x 156	126	0.124
210	DP210	1558	PKK 228 stay 170	55 x 206	176	0.179

1) example arrangement. Other energy chains can also be used with corresponding outside dimensions.
2) Outside dimensions of the energy chain

dimensions steel trough

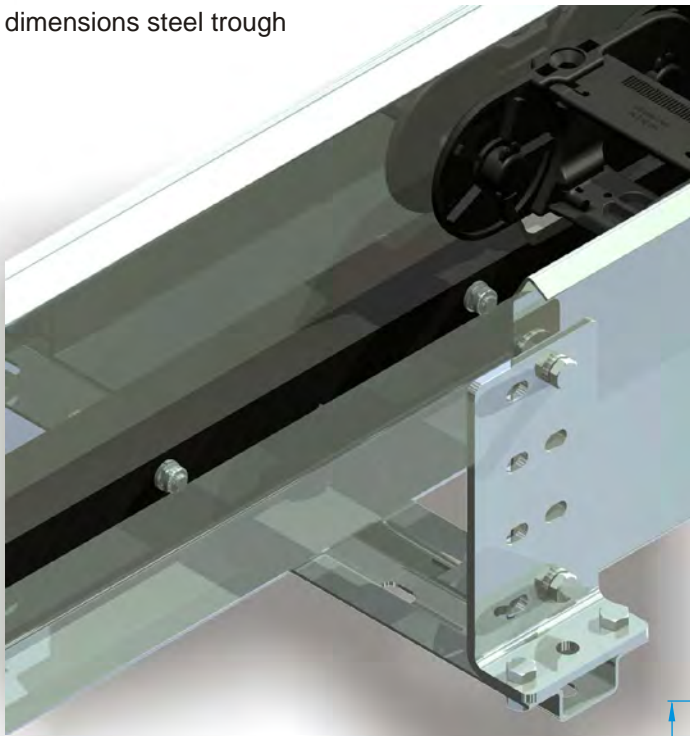

dimensions steel trough:
 the height of the trough angle depends on the energy chain used:
 example: PKK 328
 trough angle height 200 mm
 connector angle height 160 mm

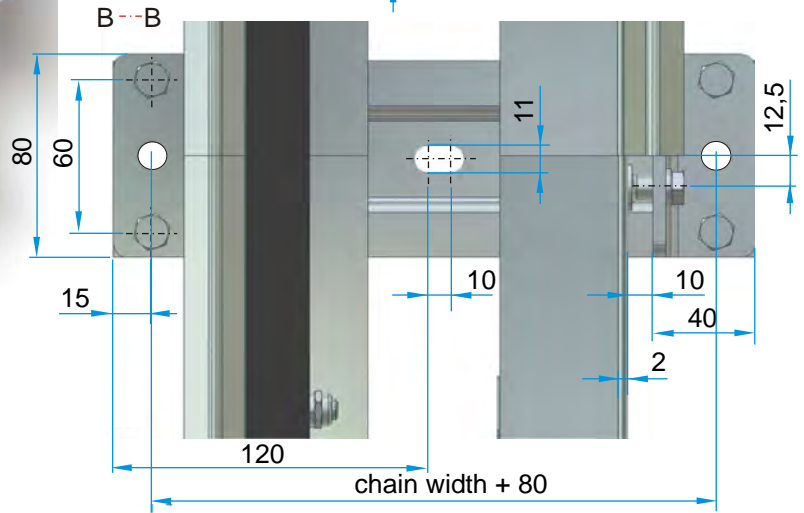
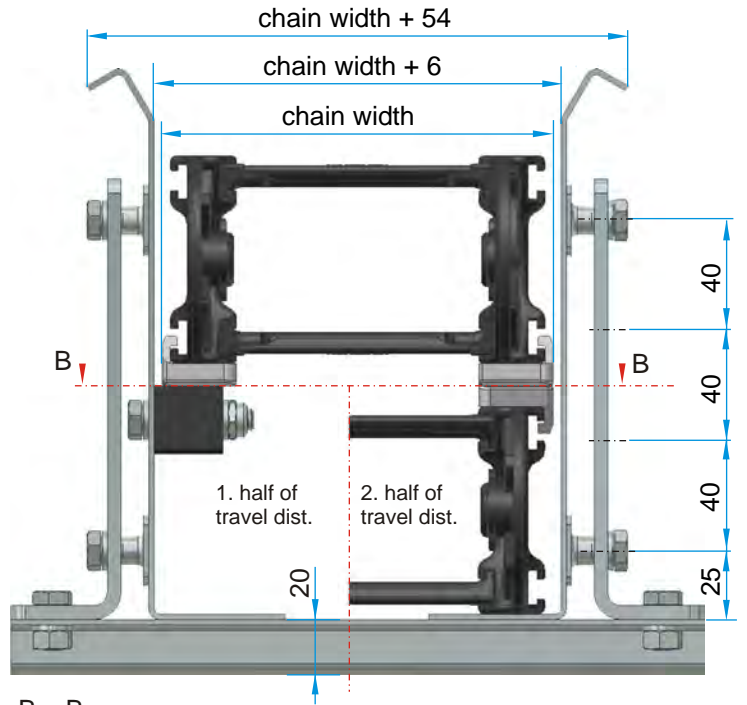

dimensions aluminium trough:

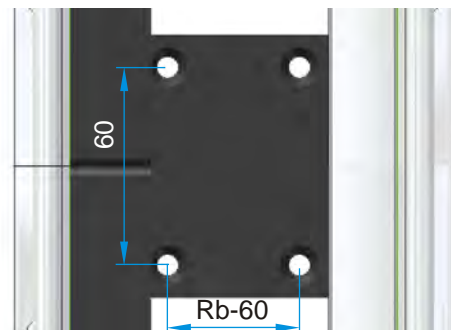
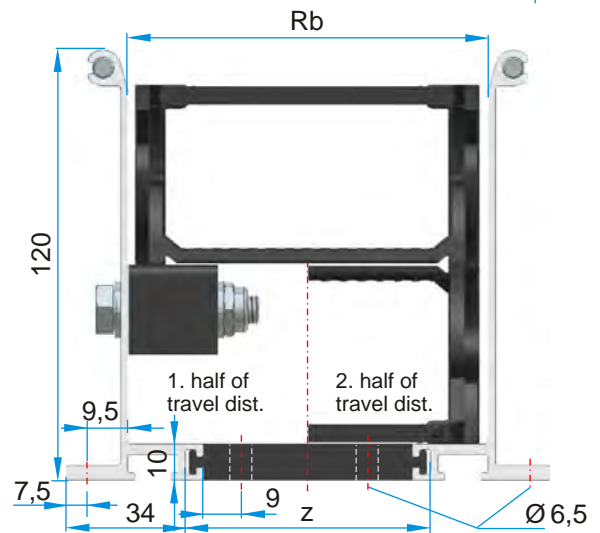
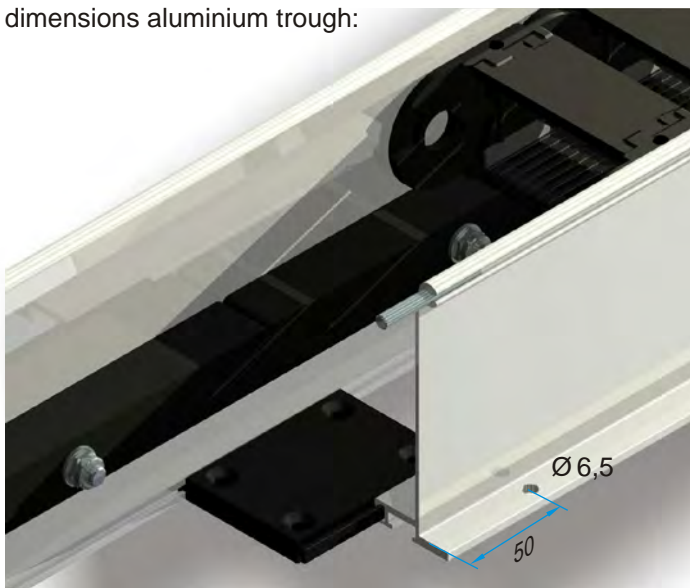

Gliding arrangements

For travels up to about 60 meters, speeds of $v_{max} = 1.5 \text{ m/s}$ and accelerations of a $max = 1 \text{ m/s}^2$ energy chains and troughs can be used.

Exceeding these values contact ekd gelenkrohr when planning your application.

The upper part of the chain runs up to half of the travel on slide bars that are bolted to the channel segments.

For long travels and heavy chains a lower connector assembling is required to guide driver initiated forces in the energy chain direction. A reduction to the height of the chain radius is usually sufficient.

The fixed connector area is designed to ensure a smooth transition of the energy chain. In addition, the slide bars in the end zone are contour adjusted. The energy chain can be attached separately with a countersunk screw or be mounted together with the slide bar. In addition, the glide bar must be provided with a corresponding reduction.

Lower connectors need an additional chain length:

Not to burden the energy chain in the end position some (according to the application) chain links have to be fitted with an reverse bending radius, so that the driver stops at a sufficient distance in front of the chain bow end.

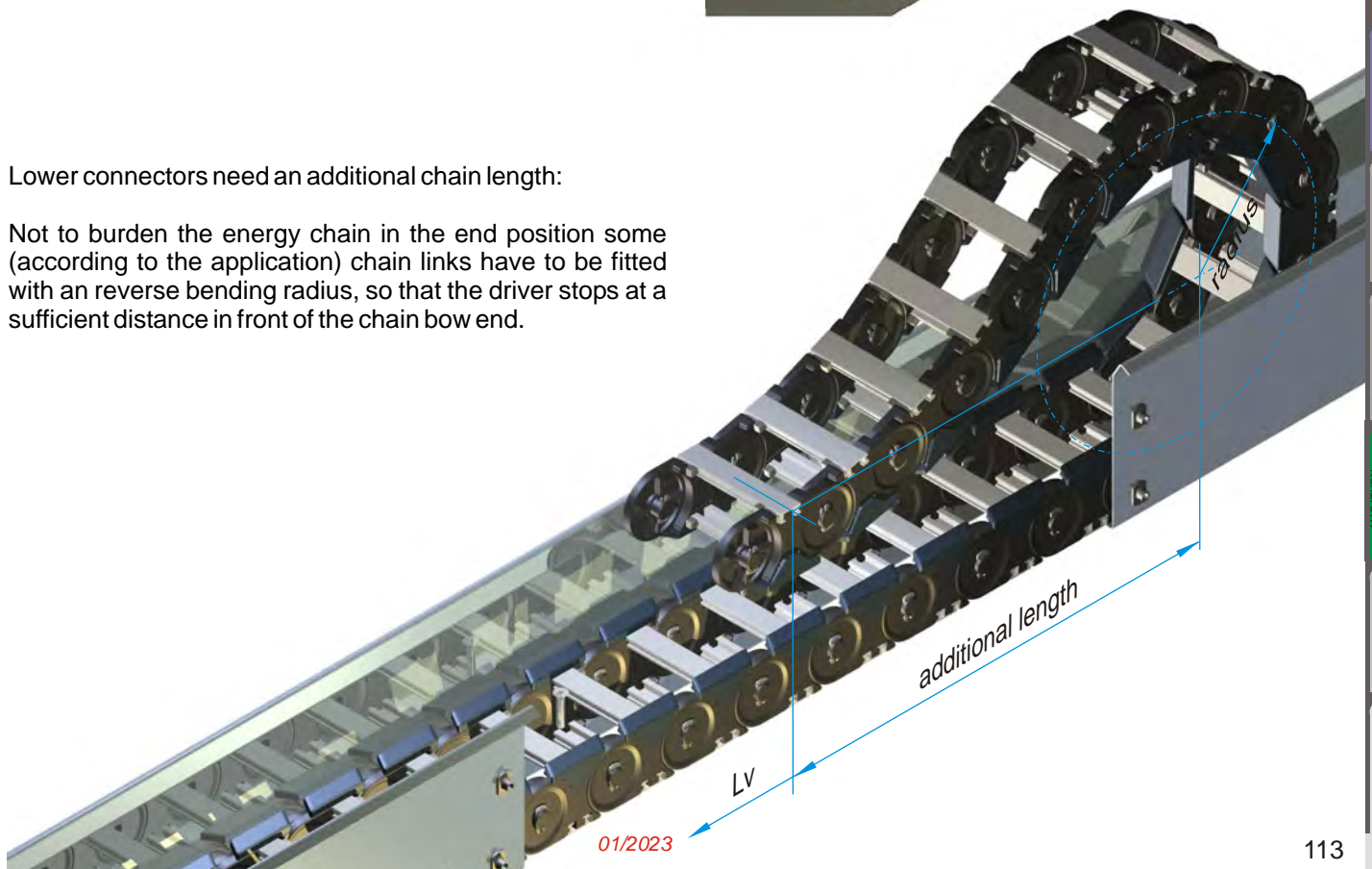
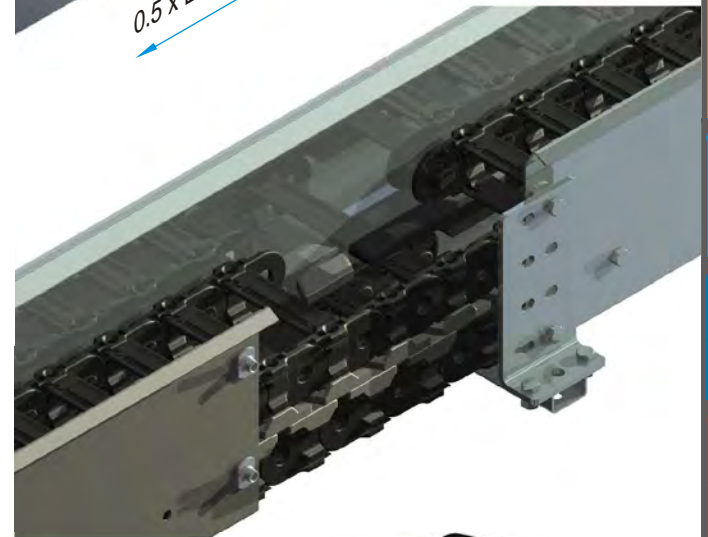
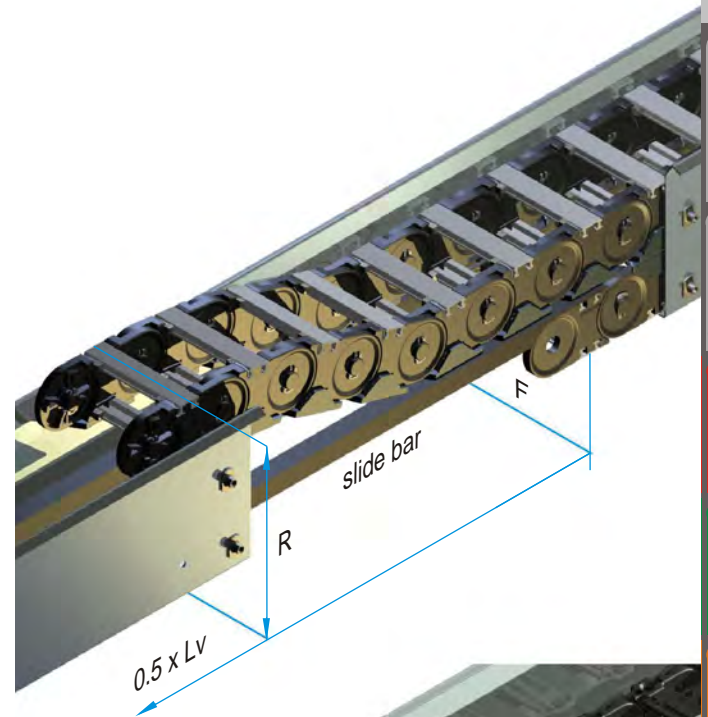



ENERGY CHAIN SYSTEMS are called components, modules or complete items ready for connection. ekd energy chain systems are offered as a service package with all necessary planning and realization steps through to testing and production release.

This usually begins with the definition of the requirements in the travel distance, number of cycles other factors, such as environmental conditions and media influences and the available design space. From this data the amount and type of cables, their connections and the energy chain can be specified.

Cables

ekd gelenkrohr as a system supplier cooperates with all leading cable manufacturers. According to customer specifications ekd can work out an efficient and price-optimized solution in the system - whether power, bus, hybrid, or special cables with or without connectors.

The same applies to hydraulic lines. Standards and standard components are scheduled as early as the design phase, as well functional as cost-optimized.

Energy chains

The selection and design of an optimized energy chain or where the application requires a custom-tailored solution is based on decades of experience.

System

With the creation of individual strain relief systems, guide rails, troughs and enclosures the projects are completed to ready-assembly systems - including accompanying documentation.

Transit, maintenance and service

The complete assembly is shipped or after consultation with customer be installed by experienced ekd assemblers on site. Maintenance and service remains in the hands of customer or can be arranged individually.

The result is a flat rate for the energy guiding system, which frees the user of logistics, efforts and cost overruns.

Pos.	Art.Nr.	Bezeichnung	Norm / Zeichnung	Werkstoff	Anzahl
1	1380	PKK 211/100x1500/120	Katalog		(1)
1.1	1300	Linsche PKK 210 R100		PKK GF 35	42
1.2	0384	PKK 220 Seq. 120		PKK GF 35	42
1.3	0404	PKK 220 Spezialriegel		PKK GF 35	42
2		Zugentlastungsblock	C-09-BM-47011		(2)
2.1		Auslenkprofil		Aluminium	4
2.2		Mittelsproff		Aluminium	2
2.3		Schraube		Stlvz	4
3		Mischergehäuse	C-09-BM-47012		(1)
3.1		Gehäuseblech		Stlvz	1
3.2		Befestigungswinkel		Stlvz	2
3.3		Schraube		Stlvz	6
4		Führungsrinne	C-09-BM-47013		(1)
4.1		Rinnenblech		Stlvz	1
4.2		Bodenblech		Stlvz	1
5		Medienversorgung			(1)
5.1		Mediering, mit Anschluss	C-09-BM-47014		4
6		Leitungsbelegung			(1)
6.1		Daten- und Sensorfth	C-09-BM-47015	Aluminium	2
6.2		Versorgung (elektr.)	C-09-BM-47016		2
6.3		Hydraulikleitungen	C-09-BM-47017		7

Bestell-Nr.	1380	Bezeichnung	PKK 211/100x1500/120
Material-Nr.	1380	Bezeichnung	PKK 211/100x1500/120
Werkstoff		Werkstoff	
Stückzahl	1	Stückzahl	1
Produktions-Nr.		Produktions-Nr.	
Gepl. Fertigungstermin		Gepl. Fertigungstermin	
Bestell-Nr.	1380	Bezeichnung	PKK 211/100x1500/120
Material-Nr.	1380	Bezeichnung	PKK 211/100x1500/120
Werkstoff		Werkstoff	
Stückzahl	1	Stückzahl	1
Produktions-Nr.		Produktions-Nr.	
Gepl. Fertigungstermin		Gepl. Fertigungstermin	

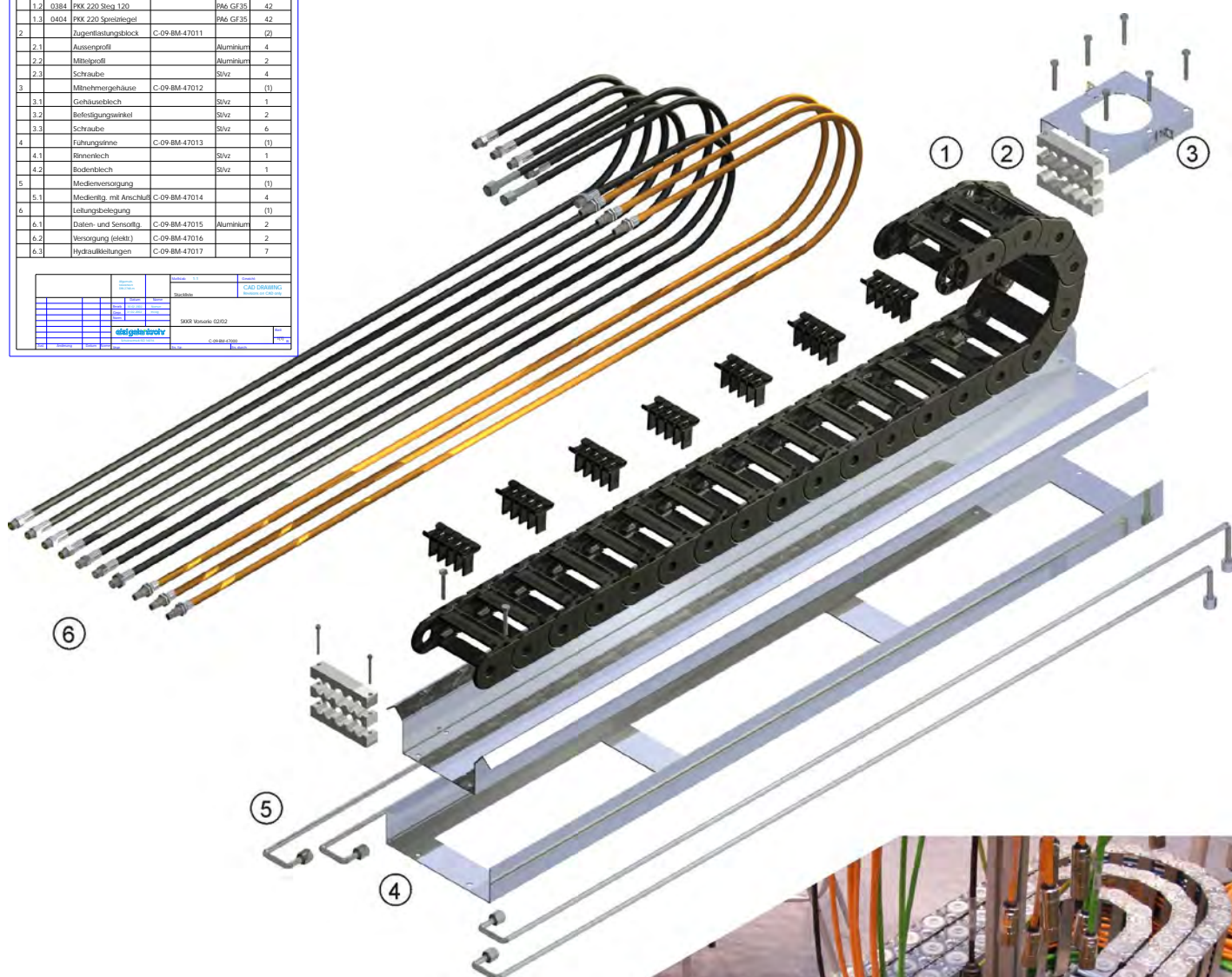

applications:

cranes, reeling systems, handling equipment,

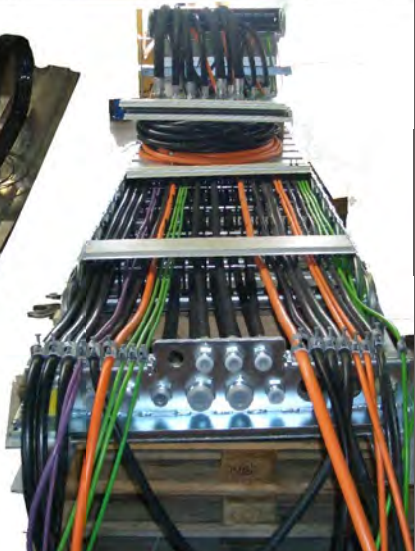
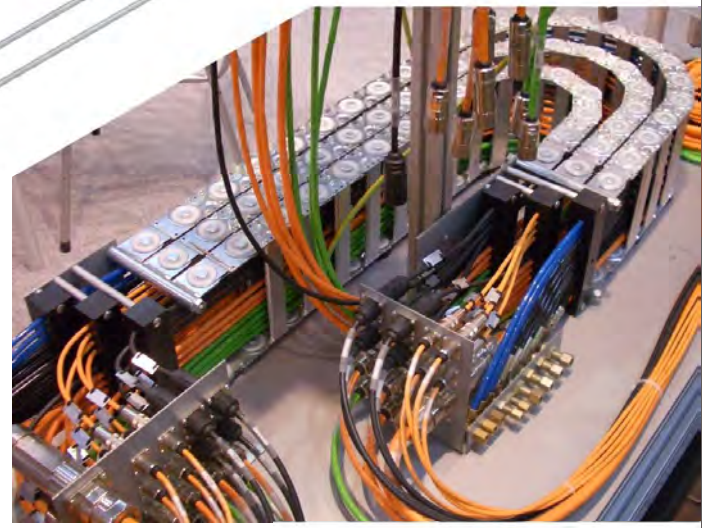
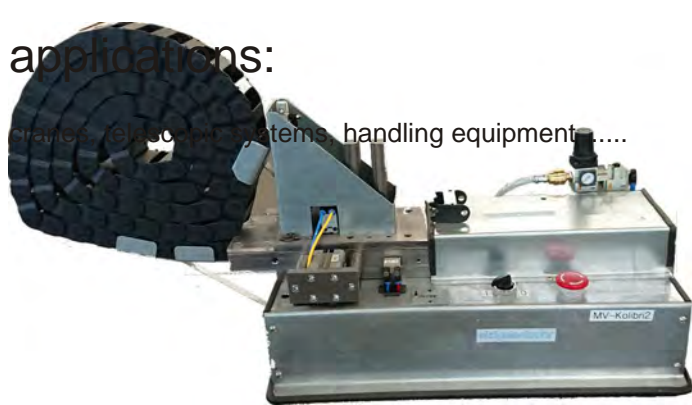



example train wash:
 free weathering
 extreme influence of media (detergents)
travel 180 m



example greenhouse:
 relative humidity 80-100%
travel 150 m

The SYSTEM MARATHON is designed for long travel distances with a rolling-led energy chain.

The upper part of the chain runs with roller sets on a continuous flat guiding rail surface. This construction avoids completely the sliding friction between the upper and lower strand of conventional energy chains. In this movement only substantially lower rolling friction occurs.

In front of the chain radius the roller sets are lifted out of the guide rail. In the chain radius the roller sets are pivoted into the trough by means of polygonal shape and the chain is lowered in the trough.

In the opposite direction of travel the roller sets behind the chain radius swirl again, embrace the guide rail and carry the upper strand centered within the trough.

Measurements for the SYSTEM MARATHON confirmed that the reduction of friction forces is up to 90%. Increased starting torque, as with sliding applications and the overcoming of static friction after a stop will not appear with this system. Not least of all SYSTEM MARATHON minimizes wear through the rolling friction.

Another advantage is the parallel to the chain running force of the movable driver and the straight arrangement of the upper run which totally avoids changing bending of the lines and the energy chain. A substantially increased durability and reliability are the result.





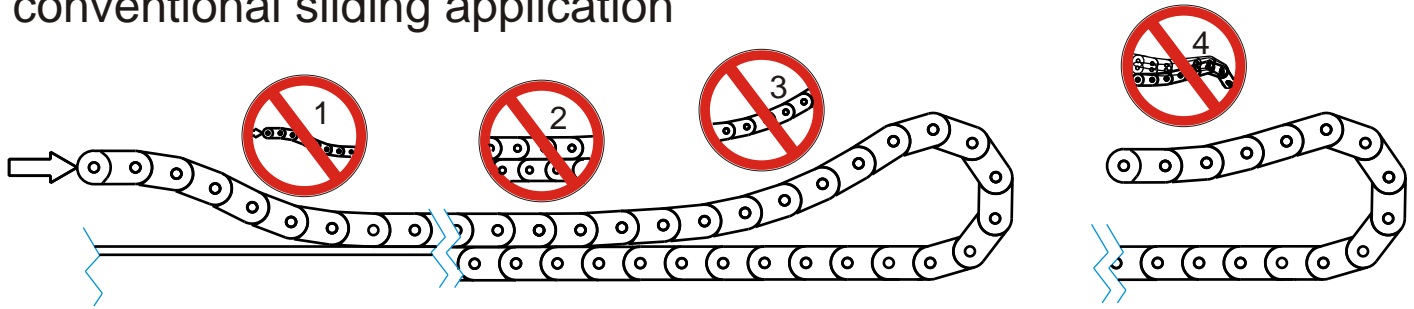

conventional sliding application

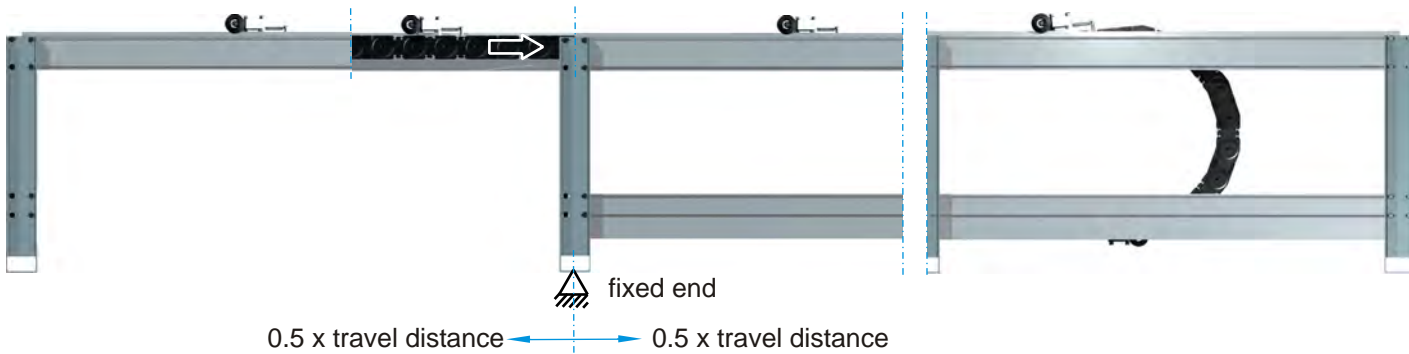

SYSTEM MARATHON



-  of force not in energy chain direction
high-flexing of the energy chain
repeated bending of the lines
-  sliding friction: high forces
high starting torque
abrasion, wear, noise
-  bending of the energy chain and
the lines
-  oscillations lead to extreme
loads of the energy chain
additional lengths often necessary

SYSTEM MARATHON

**moving forces reduced
by up to 90%
forces into the direction of
Energy chain
no repeated bending
no increased starting torques
abrasion and wear-minimizing**

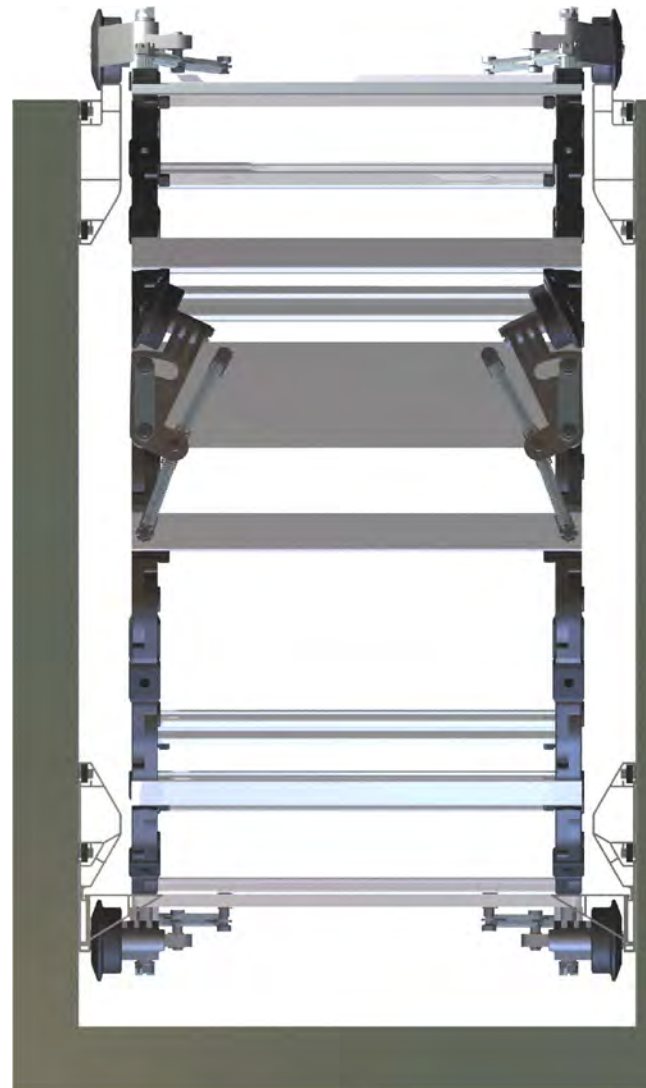



Standard energy chains do not allow lateral displacements or torsion movements. They are made of rigid material with the set on maximum unsupported length and show a straight, hard running. The energy chains SYSTEM ALLROUND open new opportunities.

By using a highly flexible link-material (thermoset elastomer) offers SYSTEM ALLROUND countless exercise options without additional design efforts.

The high flexibility of the SYSTEM ALLROUND makes the combination of several movements. The combination of two linear motion is a possible.

Just as well combined rotary or oscillating movements may overlap to simple linear movements. Thus, if there is sufficient chain length, lateral pivoting movements of 90° and axial rotation of 180° are achieved.

An almost limitless range of motion is given in a hanging arrangement at sufficient chain length.

Practical examples demonstrate the versatility of the SYSTEMALLROUND:

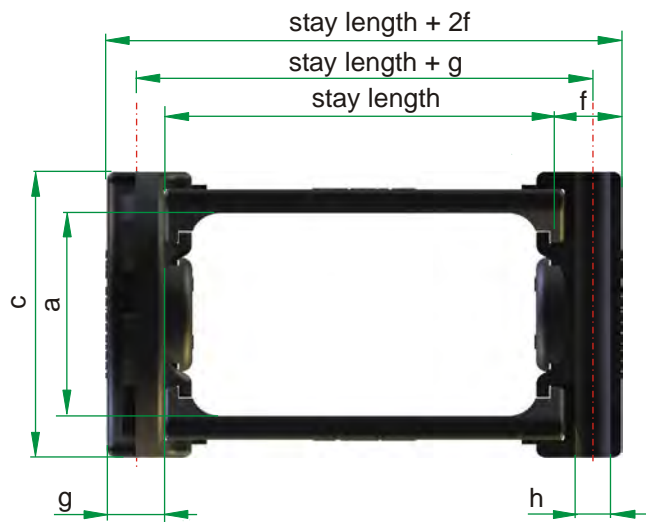

ALLROUND	bend radius R	pitch	a	c	f	g	stay length [mm]
PKK 210	65 75 100 125 150 200 300	65	34	50	10	10	50...200 (see PKK)
PKK 240	75 100 150 200 300	65	44	60	10	10	50...200 (see PKK)
PKK 310	100 130 150 200 300 400	90	51	75	12	12	50...300 (see PKK)
PKK 340	100 130 150 200 300 400	90	60	85	12	15	50...300 (see PKK)
PKK 520	150 200 300 400 500	115	80	104	20	14	50...300 (see PKK)

The connector links of the SYSTEM ALLROUND are manufactured in the standard material PA 6 GF 35. A combination of standard links and ALLROUND links achieve applications with specific features are available on request.

order example:
PKK 220 / 200 x 3510 / 100 ALLROUND
 type radius X length / stay variant

SYSTEM ELTOLA

ELastic TOrsion LA bearing is the combination of noiseless and low wear. The elastic torsion bearing replaces the conventional chains existing sliding pivot with a friction free connection. The relative movement between adjacent links is guided over the elastic torsion bearing.

In the angular motion is through this design with ELTOLA a torque transferred between the adjacent chain links, which increases starting from the neutral zero position with increasing twist angle. As a result a progressive damping of the polygon movement and a low noise, extremely quiet running is achieved.

All ekd plastic chains may be equipped with the SYSTEM ELTOLA.

ELTOLA is designed for applications with fast and noise-sensitive and large acceleration movements.

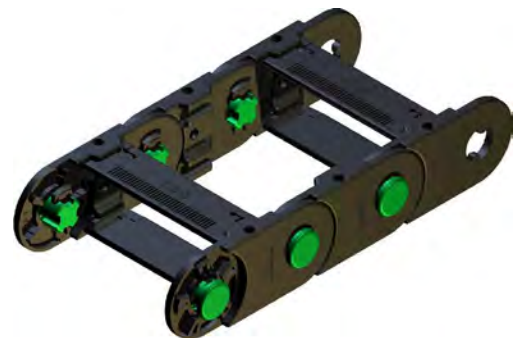

order example:

PKK 220 / 200 x 3510 / 100 ELTOLA
 type / radius x length / stay length variant

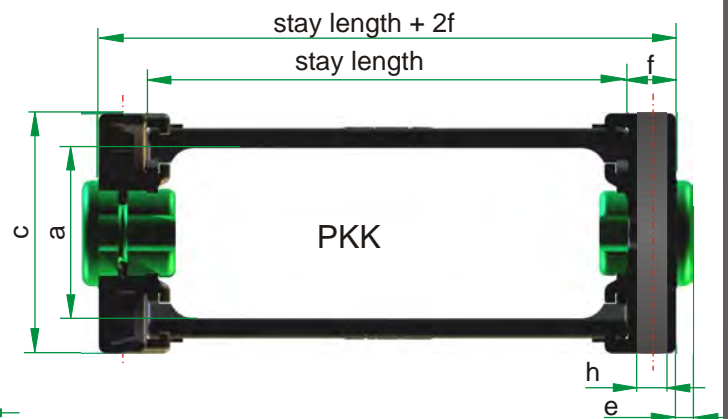
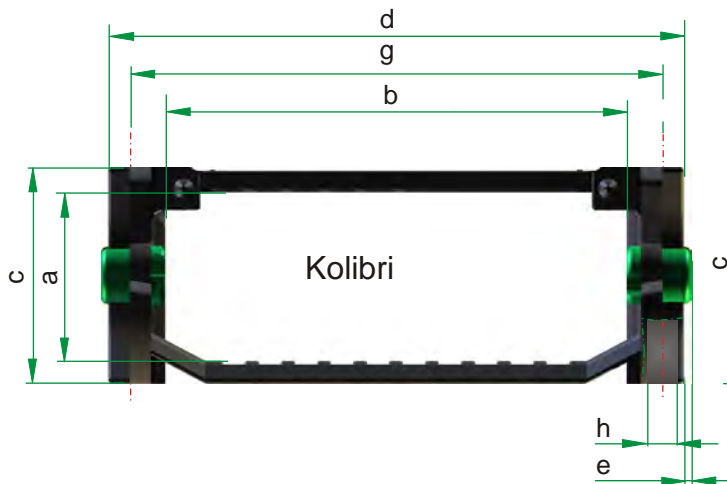

ELTOLA	bend radius R		pitch	a	b	c	d	e	f	g	h	stay length [mm]
Kolibri 30.050	75	100	35	23	34	30	50	1	-	40	5	-
Kolibri 30.060	75	100	35	23	44	30	50	1	-	40	5	-
Kolibri 30.080	75	100	35	23	64	30	50	1	-	40	5	-
Kolibri 30.095	75	100	35	23	79	30	50	1	-	40	5	-
Kolibri 30.125	75	100	35	23	109	30	50	1	-	40	5	-
Kolibri 40.062	75	100	45	29	47	40	62	1	-	54	5	-
Kolibri 40.075	75	100	45	29	60	40	75	1	-	67	5	-
PKK 210	100	150	65	34	-	50	-	3,5	(see PKK)			-
PKK 220	75	100	125	34	-	50	-	3,5	(see PKK)			-
PKK 240	75	100	150	44	-	60	-	3,5	(see PKK)			-
PKK 310, 320	300		90	51	-	75	-	3,5	(see PKK)			-
PKK 340	200		90	60	-	85	-	3,5	(see PKK)			-

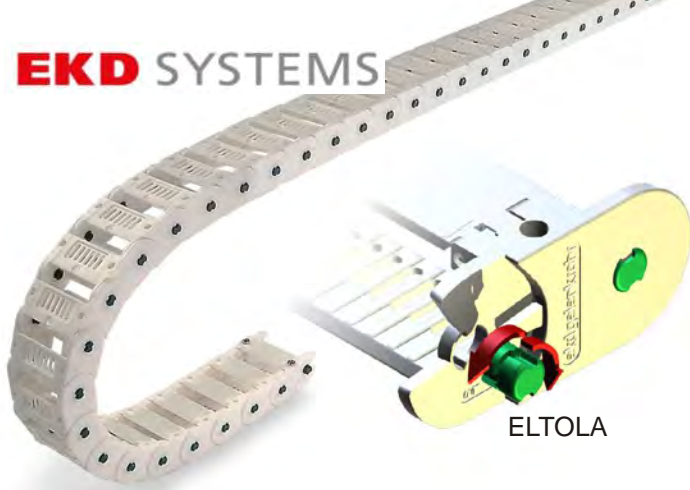

ELTOLA

The principle of the energy chain **REINTEC** is the avoidance of friction at the links and pins of conventional chains through a friction free connection:

The relative movement between the chain links is guided over the torsion bearing **ELTOLA** that positively connects links and is made of a special material. The links are spaced apart, thus preventing wear and abrasion.

REINTEC has significant advantages in comparison to known energy chains:

- abrasion and wear are optimized while maintaining the stability equal to standard cable chain
- quiet running through progressive torsion force

applications:

chip technology, food and textiles, painting and others.



Fraunhofer
TESTED
DEVICE[®]

ekd gelenkrohr „Reintec“
Report No. EG 0111-250

IPA-Qualifizierungsurkunde

Hiermit wird bescheinigt, daß für untenstehendes Produkt des Unternehmens
ekd gelenkrohr GmbH

Steinof 47
D-40699 Entrath

das IPA-Qualifizierungsiegel mit der Bericht-Nummer EG 0111-250 vergeben wurde.

Die Energieführungsreihe der ekd gelenkrohr GmbH des Typs „Reintec“ ist bei den Vorfahrtgeschwindigkeiten $v=0.2\text{ m/s}$, $v=0.6\text{ m/s}$, $v_0 = 1.4\text{ m/s}$ und $v = 2.8\text{ m/s}$ geeignet, um in Räumen der Luftreinheitsklasse „Class T“ (nach US Federal Standard 209F) eingesetzt zu werden.

Detaillierte Informationen sowie die Parameter der Prüfumgebung entnehmen Sie bitte dem IPA-Bericht der Fraunhofer-Gesellschaft.

Bescheinigt am 21. November 2001.

Die zeitliche Gültigkeit dieser Bescheinigung ist unbegrenzt. Weitere Informationen finden Sie auf der Website <http://www.ipa-qualification.com>

Stuttgart, den 21. November 2001

Heidi Gamm
Unterschrift

Fraunhofer
Institut
Produktionstechnik und
Automatisierung

order example:

Kolibri 30.050.0 / 100 x 3500 REINTEC
type / radius x length variant

Fraunhofer Institut für Produktionstechnik und Automatisierung classified a system of energy chain and cables as class 1 according to DIN EN ISO 14644-1.

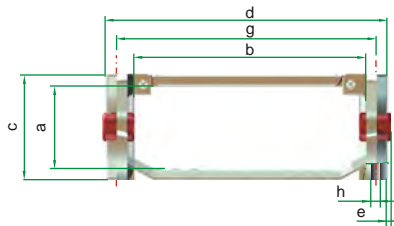

SYSTEM REINTEC	bend radius R	pitch	a	b	c	d	e	f	g	h
Kolibri 30.050.0	75 100 150 200 35		23	34	30	50	1	-	40	5
Kolibri 30.060.0	75 100 150 200 35		23	44	30	60	1	-	50	5
Kolibri 30.080.0	75 100 150 200 35		23	64	30	80	1	-	70	5
Kolibri 30.095.0	75 100 150 200 35		23	79	30	95	1	-	85	5
Kolibri 30.125.0	75 100 150 200 35		23	109	30	125	1	-	115	5
Kolibri 40.062.0	75 100 150 200 45		29	47	40	62	1	-	54	5
Kolibri 40.075.0	75 100 150 200 45		29	60	40	75	1	-	67	5

classification		maximum allowed particle concentration acc DIN EN 14644-1 with particle dimensions																				
DIN EN ISO 14644-1	EG-GMP "at rest"	EG-GMP "in operation"	US Fed. Standard 209E*	0,1 µm			0,2 µm			0,3 µm			0,5 µm			1,0 µm			5,0 µm			
				pro m³	pro cbf	pro m³	pro m³	pro cbf	pro m³	pro m³	pro cbf	pro m³	pro m³	pro cbf	pro m³	pro m³	pro cbf	pro m³	pro m³	pro cbf		
1				10	0.3	2																
2				100	3	24	1	10	0.3	4	0.1											
3				1,000	30	237	7	102	3	35	1	8	0.2									
4		1		1,240	35	265	8	106	3	35	1											
			10	10,000	300	2,370	67	1,020	29	352	9.9	83	2									
				12,000	340	2,650	75	1,060	29	353	10											
5	A/B			100,000	2,833	23,700	671	10,200	289	3,520	100	832	24									
		A								3,520	100										29	
			100							3,520	100										20	
6						26,500	750	10,600	300	3,530	100										29	
				1,000,000	28,329	237,000	671	102,000	2,890	35,200	997	8,320	235									8
			1,000							35,300	1,000										247	7
7	C									352,000	9,972	83,200	2,357									83
		B								352,000	9,972											82
										352,000	9,972											82
										353,000	10,000											70
8	D									3,520,000	99,716	832,000	23,569									830
		C								3,520,000	99,716											821
										3,520,000	99,716											821
9										3,530,000	100,000											700
										35,200,000	997,167	8,320,000	235,694									8,300

source: Fraunhofer Institut Produktionstechnik und Automatisierung (Fraunhofer IPA), Stuttgart, 2008



STEEL galvanized

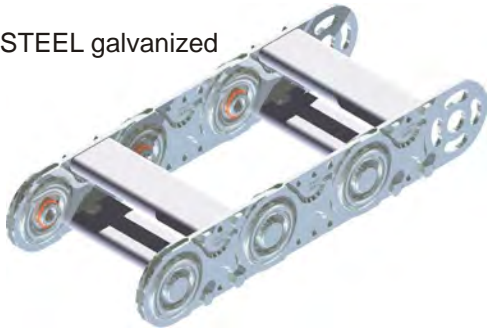

STEEL hardened carburated

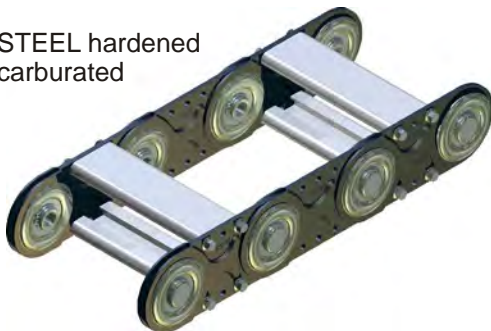

STAINLESS STEEL



ekd energy chains are made from high quality materials according to ekd specified material minimum values. Continuous Inspection of incoming and outgoing goods in connection with the requirements of the ISO 9001 quality management system guarantee a consistently high reliability.

Environmental aspects are taken into account by complying with specified regulations for the selection of materials and manufacturing processes (RoHS directive 2002/95/EC, directive 2006/122/EC PFOS, RL 1907/2006/EC REACh).

Furthermore there are negative listings (absence lists) for environmentally hazardous substances to prevent bring in the market of so-called problem substances.

Energy chains made of steel

Galvanized steel

ekd energy chains are made of high strength steel with a minimum tensile strength of 560 N/mm^2 ($R_m > 560 \text{ N/mm}^2$) and standard electroplated galvanized.

Stays and covers (**silver star**) consist of a seawater-resistant aluminum alloy (Al Mg Si 0.5).

Steel hardened (carburated)

Steel chains with high dynamic loads (eg when traversing over 1 m/s) are manufactured in hardened version. Through the special surface hardening process a very good wear resistance combined with high toughness of the energy chain is reached. This also results in an excellent and free of pollutants corrosion protection. Specially in the case of high cycle numbers hardened (carburated) links lead to longer life times.

Visual differences between the chains of the galvanized steel chains is a dark, pale appearance of the links. In this version, stainless steel screws and bolts should be used, too. The retaining rings are made of a bronze alloy.

Stainless steel

For extreme demands on corrosion resistance (eg, sea water resistance) this energy chains are made of a suitable stainless steel.

Energy chains made of steel and stainless steel are suitable for operating temperatures from $-40 \text{ }^\circ\text{C}$ to $400 \text{ }^\circ\text{C}$.

Plastic energy chains

ekd plastic energy chains are manufactured from high quality polyamide. In addition the series PLE with stays of seawater resistant aluminum and chains made of the plastic Kolibri and PKK are in the product range.

The standard material is polyamide 6 reinforced with 35% glass fibres (PA 6 GF 35). The continuous service temperature range for energy chains made of this material is -20 ° C to 100 ° C. Outside these limits a significant decrease in the mechanical strength characteristics must be expected. A detailed design is then essential.

The resistance to environmental influences is generally very good except for concentrated acids and bases, see chapter chemical resistance. Depending on the order, polyolefins can be used that provide chemical resistance in a wide range of applications.

For special applications, the material is modified:

High impact (HI), food applications (FDO), flame retardant (V-0), for explosion-endangered areas (EX) or against electrostatic discharges (ESD).

To optimize the flexibility energy chains they are manufactured from non-reinforced polyamide 6 and polyamide 66, and thermoplastic elastomers (SYSTEM ALLROUND).

With a combination of special construction and material properties in particular for clean room applications excellent technical results are achieved (SYSTEM REINTEC).

All components of the plastic energy chains are made of thermoplastic materials that are recyclable.

Plastic energy chains are suitable for operating temperatures from -20 ° C to 100 ° C.

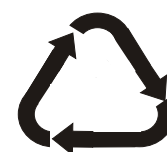
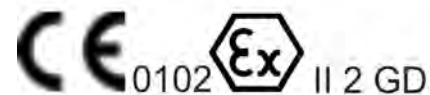
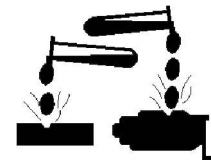

Listed properties are guide values and may be used as knowledge base. The ekd material specifications may differ from this values and are under reservation of necessary technical changes.

Property (standard)	Test condition	Value		Unit
		d.a.m.	conditioned	
Mechanical properties				
Yield stress (ISO 527)	5 mm/min	170	120	MPa
Yield strain (ISO 527)	5 mm/min	3,0	7,0	%
Tensile modulus (ISO 527)	1 mm/min	10000	7000	MPa
Charpy impact strength (ISO 179u)	23 °C	100	110	kJ/mm ²
Charpy impact strength (ISO 179u)	-30 °C	85	85	kJ/mm ²
Flexural modulus (ISO178)	2 mm/min	9000	5500	MPa
Flexural strain at flexural strength (ISO 178)	2 mm/min	4,0	6,0	%
Thermal properties				
Melting temperature (ISO 11357-1, -3)	10 °C/min	213		°C
Temperature of deflection (ISO 75-1, -2)	1,8 MPa	ca. 200		°C
Coeff. of linear therm. exp., paralle (ISO 11359)	23 to 55°C	0,2		10 ⁻⁴ /K
Coeff. of linear therm. exp., transv. (ISO 11359)	23 to 55°C	0,9		10 ⁻⁴ /K
Thermal conductivity (ISO 8302)	23°C	0,3		W/(mK)
Burning behavior (UL 94)	1,6 mm	HB		-
Electrical properties				
Relative permittivity (IEC 60250)	100 Hz	4,0	10	-
Relative permittivity (IEC 60250)	1 Hz	4,0	5,0	-
Volume resistivity (IEC 60093)		1E13	1E10	Ohm m
Surface resistivity (IEC 60093)		1E14	1E12	Ohm
Other properties (23°C)				
Water absorption (saturation value)	water at 23°C	ca. 6,5		%
Water absorption (equilibrium value)	23°C, 50% r.h.	ca. 1,8		%
Density (ISO1183)		1400		kg/m ³
Glass fibre content (ISO 3451)		35		%

MATERIAL DATA SHEET

PA 66 (HIGH IMPACT)

Listed properties are guide values and may be used as knowledge base. The ekd material specifications may differ from this values and are under reservation of necessary technical changes.

Property	(standard)	Test condition	Value		Unit
			d.a.m.	conditioned	
Mechanical properties					
Yield stress	(ISO 527)	5 mm/min	60	40	MPa
Yield strain	(ISO 527)	5 mm/min	8,0	12,0	%
Tensile modulus	(ISO 527)	1 mm/min	2100	1100	MPa
Charpy imp. strength (notched)	(ISO 179/1eA)	23 °C	18	100	kJ/mm ²
Charpy impact strength	(ISO 179/1eU)	23 °C	n.b.	n.b.	kJ/mm ²
Flexural modulus	(ISO178)	2 mm/min	2000	1000	MPa
Flexural strain at flexural strength	(ISO 178)	2 mm/min	80	40	%
Thermal properties					
Melting temperature	(ISO 11357-1, -3)	10 °C/min	258		°C
Temperature of deflection	(ISO 75-1, -2)	1.8 MPa	ca. 80		°C
Coeff. of linear therm. exp., transv.	(ISO 11359)	23° bis 85°C	0,7		10 ⁻⁴ /K
Thermal conductivity	(ISO 8302)	23 °C	k.A.		W/(mK)
Burning behavior	(UL 94)	1,6mm	HB		-
Electrical properties					
Volume resistivity	(IEC 60093)		1E17	1E14	Ohm m
Surface resistivity	(IEC 60093)		2E13	2E12	Ohm
Other properties (23°C)					
Water absorption		24h,23°C	ca. 0,75		%
Density	(ISO1183)		1080		kg/m ³
Glass fibre content	(ISO 3451)		0		%

The following list of substances and compounds are reference values for the resistance of polyamides. Polyamides are generally resistant to aliphatic and aromatic hydrocarbons (eg, fuel), fats and oils and to many organic solvents. Polyamides are not resistant to organic and inorganic acids, some even in low concentrations, as well as to strong oxidizing agents. Fittings made of polyamide are generally regarded as stress crack resistance.

resistant

acetone	acetylene	allyl alcohol	ammonia	ammonium nitrate
ammonium sulfate	benzene	beer	bio gasoil	bitumen
brake fluids	bromo	butane	butanol	camphor oil
chlorobenzene	citric	citrus	cyclohexanol	
dibutylphtalat	gasoil	dibutyl ether	dimethylamine	dioxane
ferricIII chloride (neut.)	petroleum	ether gas	ethane	ether
ethyl acetate	ethylene	ethylene oxide	CFC	fatty alcohols
fats, waxes	fish oils	fixing baths	photo developer	fruit juices
furfural	gelatin	gear oil	glycerol	urea (20%)
heating oil	heptane	hexan	hexachlorobenzene	isocyanate
potassium carbonate	potassium chloride (10%)	isopropanol	isooctane	ketones
co2	carbon fuels (gasoline)	copper sulfate	linseed oil	
seawater	methane	lactic	mineral oils	
sodium carbonate	sodium chloride	sodium sulfide		phosphates
sodium hydroxide (10%)	paraffin oil	petroleum ether	lamp oil	
phosphoric acid (30%)	rapeseed oil	propane	carbon disulphide	soda solution
hydrogen sulphide	welding solution (pH 9.5)	silver nitrate(10%)	silicone	
nitrogen	styrene	tallow (beef fat)	turpentine	
carbon tetrachloride	tetrafluoromethane	ink	toluene	urine
tartaric acid	xylene	benzene hydrogen	sugar solution	

conditionally stable

acetaldehyde	aniline	benzyl alcohol	chloroform	vapor
diethylene glycol	dimethyl formamide	dimethylsuloxid	ferric III chloride, acidic, watery	
acetic acid (5%)	ethanol, conc.	ethylene glycol	formaldehyde (10%)	formamide
glycol	hydraulic fluids	potassium dichromate	potassium hydroxide, conc.	
methyl alcohol	oxalic acid (10%)	phosphoric acid (10%)	sulfur dioxide dry	propanol
sulfuric acid	vinyl chloride	triethanolamine	trichlorethylene vapor	
tin chloride (aqueous)				

unstable

acrylic acid	formic acid (10%)	benzaldehyde	bromide	butyric acid (conc.)
calcium hypochlorite	chloramines	chlorine	hydrochloric	acetic acid (30%)
hydrofluoric	hydrofluoric acid (40%)	iodine	iodide	perchlorate (2%)
potassium	permanganate (10%)	solder liquid	sodium hypochlorite	20 ppm of ozone
nitric acid	perchloric acid (1%)	hydrochloric acid (1%)	oxygen	sulfuric acid(10%)
thionyl chloride	trichloroacetic	trichloroethyl hydrogen peroxide (10%)		cinnamaldehyde
Zinc halides (aqueous)				

soluble

formic acid (85%)	calcium chloride	aniline	alcohol. Chloral hydrate	
dimethylformamide	ethylene glycol	dimethyl	phenol	cresols
hydrochloric acid conc.	sulfuric acid (96%)			

About this catalogue

Descriptions and technical informations which are shown in this catalog are purely informative and serve only the general information. An assurance of properties for certain applications is denied. The catalog reflects the technical state of the art at the time of the edition. Changes to the products remain at any time. The in the order and contract agreed properties of the product is binding.

All copyrights of all texts and illustrations in this catalog are EKD Systems GmbH owned. Copies of whatever kind and disclosure to third parties requires the express consent of EKD Systems GmbH.

General operating and safety instructions

Energy chains are technical products, which are constructed as part of an engineering-design for concrete applications according to the state of the art. In dealing with these products the compliance to the operating and safety instructions and general rules of technology is assumed.

Thus, for example, the stay in the work area of an energy chain is only allowed if adequate safeguards are in place to prevent accidental moving of the chain. The accident prevention regulations are strictly to be observed. Further requirements, such as when operating in explosive hazardous areas are - if applicable - to take into account as well.

The intended use has to be in compliance with the design limits of energy chains. The below known from practical experience can lead to considerable functional errors or damage of the energy chain:

- improper handling of the energy chain during transport and assembly
- undue weight load of the energy chain, especially of a free carrying upper strand of the chain
- operating the energy chain out of the limits of the designed travel distance
- introduction of interference contours, components or parts thereof into the operating area
- improper line load

Are the operating conditions such as wear-boundary conditions of abrasive dust entry or plant-vibration and oscillations can not be avoided, so by appropriate constructive steps and inspection intervals, particularly in unsupervised, automated operating systems, unforeseen equipment failures have to be avoid.

energy chains
lines
accessories



energy guiding
systems



complete
systems

