

Sveriges mest
kompleta leverantör
av rörlig
strömmatning

Sliprings type PME Evolution

KranEl överför kraft i rörelse

PME Evolution

Main performances

Housing	In aluminium with insulating thermoplastic bands
Positioning	Vertical axis, as illustrated here below
Connections	Rings wired with 2 m. long cable
Cable entry	With single-pole wires connected to the rings and through pipe unions M32 to the brush-holders
Brushes	20 A, 50 A and 100 A in copper-graphite
Executions	From 20 to 60 rings 20 A - mixed executions 20/50/100 A
Armonized rules	CEI-EN 60947-1 CEI-EN 60529 2014/35/UE – 2014/30/UE – 2006/42/CE Directives
Marking	CE

Functional features

Nominal voltage	660 V ac—dc
Nominal current	I_{th} 20 A - 50 A - 100 A
Protection degree	IP 65
Max rotation speed	30 revs/min
Test voltage	2,5 kV
Operating temperature	- 20 °C — + 60 °C

Accessories

Availability on demand

- Mercotac
- Absolute Encoder
- Micro-switches application
- One passage for air
- Mixed executions with 100 A, 50 A and 20 A
- Types with appropriate rings for signals

Standard types

Type	20 A N° Rings	H = mm
G PME B20	20	175
G PME B30	30	229
G PME B40	40	283
G PME B50	50	337
G PME B60	60	391



Installation and wiring

The PME Evolution slipring has to be installed only by qualified personnel in compliance with current safety standards. Power to the machine must be turned off before carrying out wiring. Connections are to be made in compliance with the wiring scheme of the controlled equipment. After installation has been completed, the installer is required to check that all commands are working properly. Avoid prolonged contact with oils and acids when using the equipment, as these may damage the products.

- 1) The base plate (ref. 1) is made by using fork fastons with interaxis 260 mm. and screws M10. Two holes of $\varnothing 9$ mm., 13 mm. deep on the flange (Ref. 7) are used for the rings. We recommend the coupling to be made with slack to take up any possible runout during rotation. Axial stress must be avoided for good functioning.
- 2) The cables are connected through lateral pipe unions (Ref. 2). The torque for brushes terminals is 0,8 Nm for the versions 20 A and 50 A, and 2 Nm for the version 100 A. During the tightening of the cables to the brushes, brush holders must be locked. Please ensure that the wires do not interfere with any moving part. The rings are cabled with a 2 m long cable from the main plate (Ref. 1). Longer cables are available upon request.
- 3) Please check the equipotential of any surface not generally recommended to be used under tension, and the ground connection using the cables provided.

Maintenance

A programme of periodical maintenance is required to be carried out to ensure that the PMP Evolution slipring is kept in perfect working order. All maintenance is to be effected by qualified personnel using only original spare parts. Any defective or altered parts must be be replaced promptly, even outside the maintenance schedule, as they could impact on the safety of the device. In particular:

- 1) Disconnect from power source and wait until the internal parts have cooled down.
- 2) Remove the cover (ref. 6), the bands (ref. 5) and the gaskets (ref.3).
- 3) Check the brushes for wear and tear, and check that they adapt properly to the rings.
- 4) Remove copper-graphite dust with de-humidified compressed air or a clean brush.
- 5) Check that the cables tightness is corresponding to the torque which is specified in our installation instructions.
- 6) Check that the cover gaskets is in good condition.
- 7) Replace the cover (ref.6), the bands (ref. 5) and the gaskets (ref.3).

Please note that the guarantee does not cover any equipment whose parts have been modified and tampered.

Dimensions

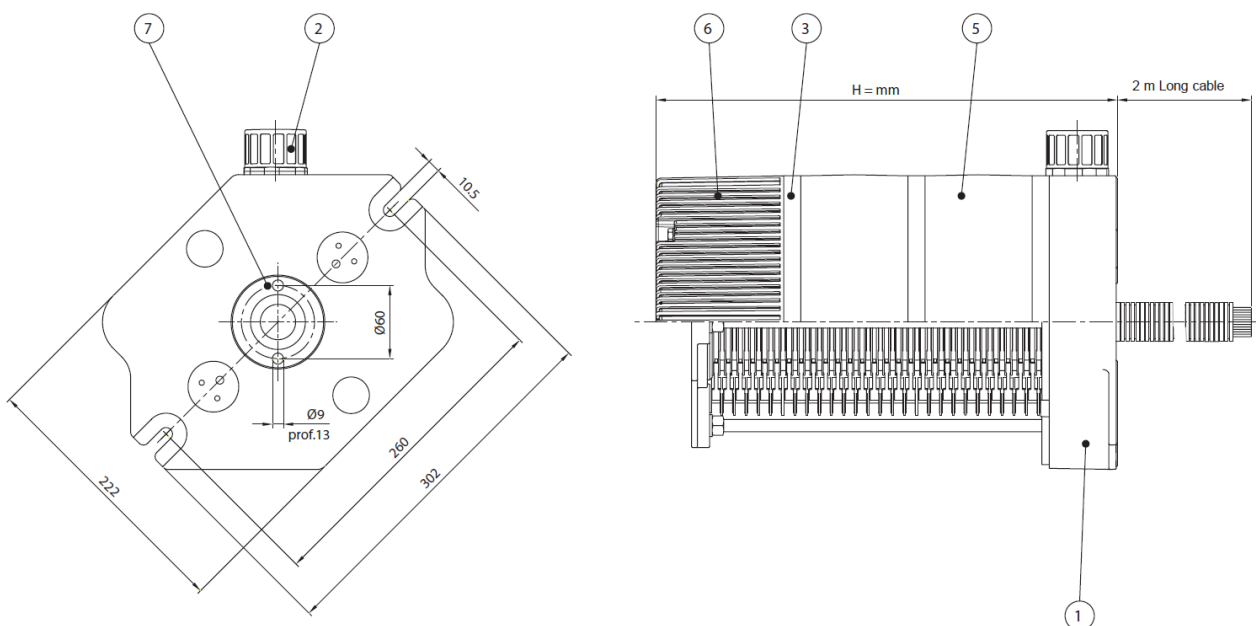

Vår erfarenhet är din
driftsäkerhet och
konkurrenskraft

Ditt mål är vårt

Vårt mål är att ni ska få ut mer av er anläggning eller maskin och bli mer konkurrenskraftig. Ökad konkurrenskraft tror vi uppnås delvis genom en optimal funktion, problemfri drift samt minskade drift- och underhållskostnader. Därför erbjuder vi allt från reservdelar till helhetslösningar med effektiv logistik.

Helhetslösning

Vi hittar den optimala lösningen för er, gärna redan på utvecklingsstadiet.

Problemlösning

Problem med befintliga applikationer? Med vår långa erfarenhet kan vi lova att vi stött på liknande problem tidigare. Prata med oss så löser vi det.

Produkt

Vi ser till att du får det du behöver med snabbast möjliga leverans.

Reservdel

Ibland räcker det med en reservdel för att få anläggningen att rulla igen. Osäker på vilken del du söker? Vi hjälper dig hitta rätt produkt.

KranEl Göteborg

Vagnmakaregatan 14
415 72 Göteborg
Tel: +46 (0)31 340 90 70

Mail: office@kranel.se

KranEl Stockholm

Reprovägen 12
183 77 Täby
Tel: +46(0)8 756 00 95