

VKS

COMPACT CONDUCTOR SYSTEMS



COMPACT CONDUCTOR SYSTEMS VKS

Contents

General	2	Expansion sections	14
Layout planning.....	5	Sectionalizing.....	15
Standard sections.....	6	Current collectors.....	15
Curved sections.....	8	Compact collectors	16
Joint material.....	8	Accessories and spare parts for collectors	18
Hangers	9	Standard brackets.....	22
End caps.....	9	Snap-on brackets.....	23
Feeds	10	Support structure.....	23
Transfer guides.....	12	Examples for ordering.....	23
Transfer funnels	13	Questionnaire.....	25

GENERAL

VAHLE conductor systems VKS are space saving conductor systems, designed to prevent any accidental contact and hazard to personnel and are test finger proof to regulations VDE 0470, part 1 (EN 60529), protection code IP 21. They comply with the accident and VDE regulations in electrical, mechanical and fire engineering cases. Collectors are proof against accidental touch only when fully entered into conductor rail.

Conductor system installations within reach of hand require a special protection on the part of operator against accidental touch of current collectors which are leaving the conductor rail (e.g. locking or cut-off the power).

This is applicable for voltages above 25 V AC respectively 60 V DC. If the cross-section of the N-conductor is smaller than the cross-section of the outer conductor, it must be protected against overcurrent and short-circuit in accordance with IEC60364-4-43 (HD 60364-4-43).

The creeping distance between the conductors of the VKS-conductor is 30 mm. The different plastic housings hold from 3 to 6 copper or stainless steel conductors. Multiple conductor systems can be easily designed by combining several plastic housings.

The minimal space required allows the systems to be integrated in the crane or hoist track or in other special runway profiles. The minimal required space allows a direct layout in rail tracks or special track profiles. The conductor systems VKS can be used for indoor and roof-over (rain protected) applications. They can be installed with lateral or suspended mounting and straight or curved tracks are available.

Approvals: UL-approval.

PLEASE NOTE

Please consult factory for galvanizing plants, pickling lines, other aggressive or deep freeze ambients, as well as low voltage and data transmission applications, indicating special environmental conditions.

To speed up quotations and order processing, we would appreciate receiving your drawings or sketches for conductor systems with curves, dead sections, turntables, switches, etc.

Please use our questionnaire on page 25.

GENERAL

Use for indoor applications, roof-over outdoor applications

Hoists, monorail systems, stacker cranes, machine tools, production and testing lines, also for sliding switches, turntables, hoisting stations, transfers, and many other applications, including data and signal transmission.

Sections

The well insulating plastic housing holds 3 – 6 conductors and offers safe isolation. The ends of each section are milled in to provide the required creepage distance. 4 or 6 m standard lengths and shorter sections to coincide with your runway requirements are available. The ground conductor is identified by the international yellow colour coding. The conductor rail for control current is without PE-marking. The asymmetrical housing avoids phase reversing.

Polarity Protection

As an option, the VKS 4 and VKS 6 models are available with additional polarity protection. These have a specially shaped protective conductor and an abrasive carbon geometry that ensures that the collector of the protective conductor cannot penetrate the phase rails. Due to the asymmetrical design, an electrification of the electrical consumer (vehicle/skid pallet/suspension) - even in case of operating errors - is excluded. With this innovation, VAHLE offers a unique advantage and a clear lead over the relevant safety regulations, especially in applications with the highest requirements for personal protection (e.g. in the automotive industry). Ask for our detailed documentation.

Joints

The plastic sections are connected with plastic joint caps, the conductors with spring-loaded copper connectors.

Hangers

All sections are to be fixed from at least 1 hanger and the maximum permissible support centres of 1000 mm (with double collectors. 800 mm), must be adhered to (see page 5). The hangers are equipped with M 6 bolts and hardware and can be mounted directly to hanger brackets, monorail tracks or special runway profiles. The sections are snapped into the hangers. Sliding hangers allow free movement of the conductor system to compensate for temperature variations. Fixpoint hangers with tapping screw from anchor points (see installation procedure). For this we have to consider a max. distance of 6 m between two fixpoints.

Electrical properties	VKS
Max. ampacity	140 A ⁽²⁾
Allowed voltage	690 V ⁽³⁾
Electrical strength DIN 53481	>25 kV/mm
Special electrical strength IEC 60093	1 x 10 ¹⁴ Ohm x cm
Surface resistance IEC 60093	2,1 x 10 ¹³ Ohm
Creep resistance IEC 60112	CTI > 400
Flammability	Flame resistant, self extinguishing, UL 94 V0

Conductor material	Cross section mm ²	Impedance 50 Hz Ohm/1000 m	Resistance Ohm/1000 m
Copper	16	1.107	1.102
	25	0.730	0.723
	30	0.603	0.595
	35	0.520	0.510

Mechanical properties	N/mm ²
Flexible strength	70 – 80
Tensile strength	40 – 53

Chemical resistance of the isolating profile at +45 °C ambient temperature	
Benzine, petroleum, fats	resistant
Caustic soda up to 50 %	resistant
Hydrochloric acid, concent	resistant
Sulfuric acid up to 50 %	resistant

Water absorption	%
Max. at 20 °C	0.06

Ambient temperature range	°C
Rail length up to 4 m	-30 ⁽¹⁾ up to +55
Rail length > 4 m	von 0 ⁽¹⁾ up to +40

(1) Consult factory for use below 0 °C (32 ° F)

(2) 80 % ED

(3) Not with UL-approval; U_{UL} = 600 V

GENERAL

Brackets

Support brackets for easy installation are available (see page 22).

Collectors

The collectors have a continuous rating of 20A up to 120A. One collector is required for each phase and earth conductor. The ground collectors have a yellow colour and different attachments to avoid interchangeability with phase collectors.

The collectors have spring loaded carbon brushes for a constant positive contact with the conductors. Collectors are to be mounted onto towing plates or are to be attached to the moving equipment by means of towing brackets type UM. Systems with transfers, switches, turntables, etc. require 2 single collectors or one double collector per conductor. The length of the collector cable may not exceed 3m if the added overcurrent protection device is not designed for the load capacity of this cable. Please refer also to regulations VDE 0100, part 430 and EN 60204-32. (Note: this might happen in case of several collectors running in one system).

The provided connecting cables are sufficient for the stated nominal currents. For the different laying procedures the reduction factors according to DIN VDE 0298-4 have to be considered.

Conductor dead sections

Conductor dead sections are electrical interruptions of the conductor. Under normal operating conditions a cross over with collectors to switch the voltage off or on is only allowed with low power ratings (e.g. control signals) and equal potentials/voltages. Conductor dead sections can be mounted at any position of the system. The plastic inserts are pushed into the copper profiles and ensure a smooth transfer of the collector brushes. The length of isolating section has to consider the total length of carbon brush and whether carbon brush must or must not bridge the isolating area.

Special attention is required for double collectors or collectors switched in parallel. Use double isolating sections where necessary.

Selection of conductors in accordance to ampere load and environmental conditions:

VKS .../63 copper conductor for power and control system and data transmission

.../**100** copper conductor for power and control system

.../**120** copper conductor for power and control system

.../**140** copper conductor for power and control system

Several combinations of cross sections are possible for one conductor type.

LAYOUT PLANNING

System layout

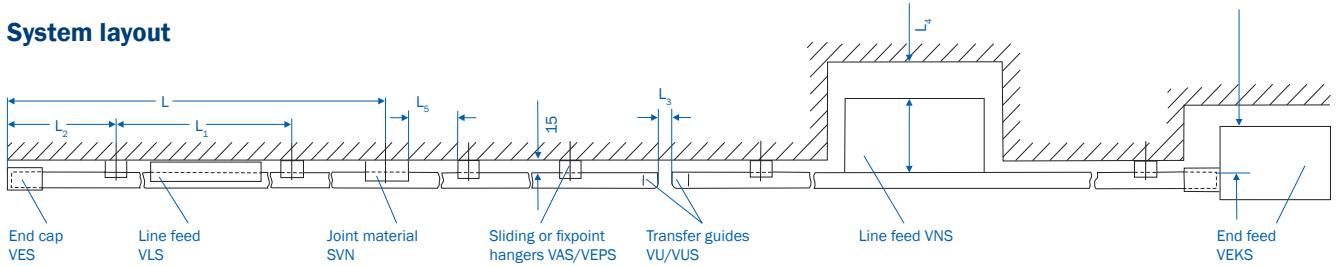

- L = Conductor rail section
(Standard lengths: 1 m, 2 m, 3 m, 4 m, 5 m, 6 m or cut to suit the system)
- L₁ = Support spacing
for straight runs: max. 1 m
for curved runs: max. 0.5 m
- L₂ = Extending length (max. 200 mm)
- L₃ = Air gap for transfers, e.g. switches and dropout sections (3–5 mm)
- L₄ = Space to remove feed box cover, if applicable
- L₅ = Clearance for expansion of conductor system (min. 50 mm)

Symbols in layout plans

		VKS
	Track	-
	Conductor rail	VKS
	Joint material	SVN
	Fixpoint hanger	VEPS
	Sliding hanger	VAS
	End cap	VES
	End feed, power	VEKS
	End feed, control	VEKS
	Line feed, power	VNS
	Line feed, control	VNS
	Line feed, power and control	VLS
	Transfer guide, straight	VU
	Transfer guide, oblique	VUS
	Transfer funnel	VEM
	Expansion section	DVKS
	Isolating assembly	VSTS

Max. Support spacing

at KSTU 30-55 (Fig. 1)	VKS
for straight runs	1000 mm 800 mm
for curved runs	500 mm 400 mm

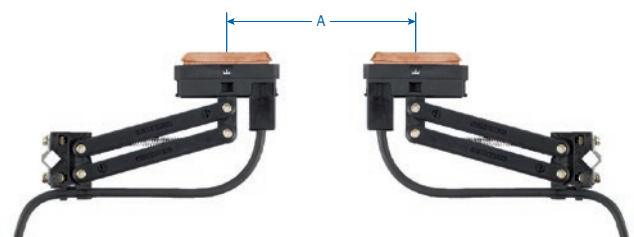

Fig. 1
A < 300 mm Support spacing 0.8 m
A > 300 mm Support spacing 1.0 m

STANDARD SECTIONS

3-pole sections

Standard length 4 and 6 m ⁽⁶⁾

Attention: Joint material to be ordered separately (see page 8).

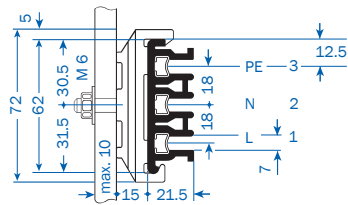

Installation: lateral

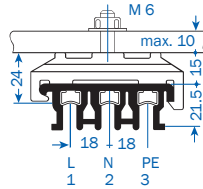

Installation: horizontal

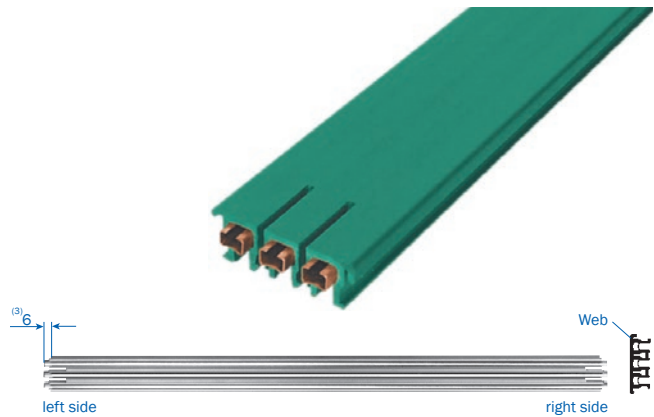

Type	No. of poles	Max. ampere rating at 35 °C A	Nominal voltage ⁽⁵⁾ V	Voltage drop per 100 m at full rating V	Conductor cross section ⁽⁴⁾ / mm ²		Conductor material	Weight kg/m	Order No.
					N, L / 1-2	PE / 3			
VKS 3/ 63 HS	3	63	690	11.5	2x16	1x16	Cu	1.221	15389 •
VKS 3/ 63 SS	3	63	690	11.5	2x16	1x16	Cu	1.221	15394 •
VKS 3/100 HS	3	100	690	12.6	2x25	1x25	Cu	1.454	15390 •
VKS 3/100 SS	3	100	690	12.6	2x25	1x25	Cu	1.454	15395 •
VKS 3/120 HS	3	120	690	12.5	2x30	1x30	Cu	1.589	15391 •
VKS 3/120 SS	3	120	690	12.5	2x30	1x30	Cu	1.589	15396 •
VKS 3/140 HS	3	140 ⁽²⁾	690	11.3	2x35	1x35	Cu	1.724	15496 •
VKS 3/140 SS	3	140 ⁽²⁾	690	11.3	2x35	1x35	Cu	1.724	15608 •

4-pole sections

Standard length 4 and 6 m ⁽⁶⁾

Attention: Joint material to be ordered separately (see page 10).

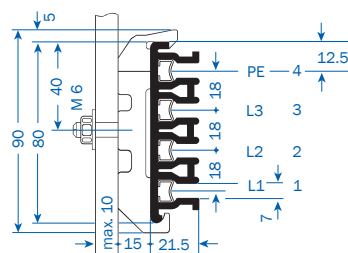

Installation: lateral

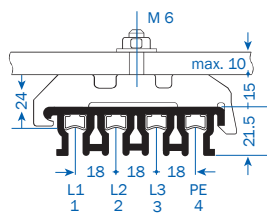

Installation: horizontal

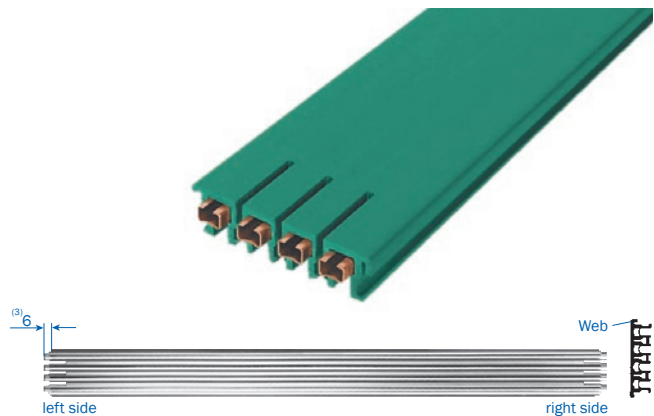

Type	No. of poles	Max. ampere rating at 35 °C A	Nominal voltage ⁽⁵⁾ V	Voltage drop per 100 m at full rating V	Conductor cross section ⁽⁴⁾ / mm ²		Conductor material	Weight kg/m	Order No.
					L ₁ -L ₃ / 1-3	PE / 4			
VKS 4/ 63 HS	4	63	690	11.5	3x16	1x16	Cu	1.459	15399 •
VKS 4/ 63 SS	4	63	690	11.5	3x16	1x16	Cu	1.459	15404 •
VKS 4/100 HS	4	100	690	12.6	3x25	1x16	Cu	1.693	15400 •
VKS 4/100 SS	4	100	690	12.6	3x25	1x16	Cu	1.693	15405 •
VKS 4/120 HS	4	120	690	12.5	3x30	1x16	Cu	1.828	15401 •
VKS 4/120 SS	4	120	690	12.5	3x30	1x16	Cu	1.828	15406 •
VKS 4/140 HS	4	140 ⁽²⁾	690	11.3	3x35	1x16	Cu	1.956	15431 •
VKS 4/140 SS	4	140 ⁽²⁾	690	11.3	3x35	1x16	Cu	1.956	15654 •

5- and 6-pole sections

Standard length 4 and 6 m ⁽⁶⁾

Attention: Joint material to be ordered separately (see page 8).

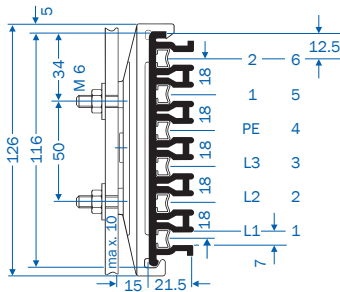

Installation: lateral

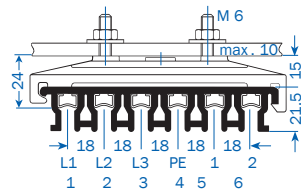

Installation: horizontal

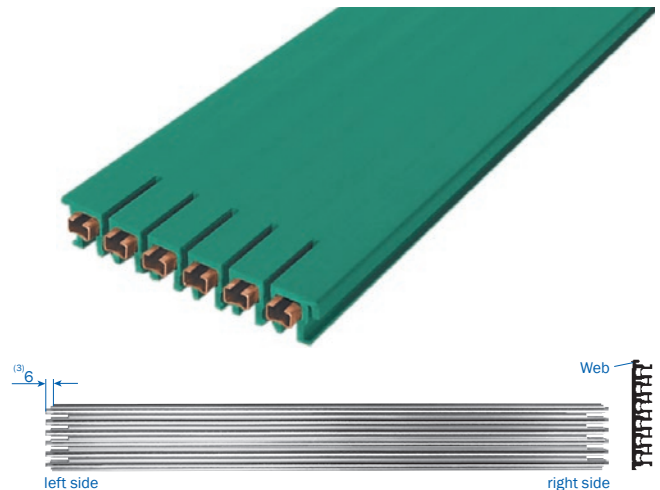

left side

right side

Type	No. of poles	Max. ampere rating at 35 °C A	Nominal voltage ⁽⁵⁾ V	Voltage drop per 100 m at full rating V	Conductor cross section ⁽⁴⁾ / mm ²			Conductor material	Weight kg/m	Order No.
					L ₁ -L ₃ / 1-3	PE/4	1.2/ 5.6			
VKS 5/ 63 HS ⁽¹⁾	5	63	690	11.5	3x16	1x16	1x16	Cu	2.058	15409•
VKS 5/ 63 SS ⁽¹⁾	5	63	690	11.5	3x16	1x16	1x16	Cu	2.058	15414•
VKS 5/100 HS ⁽¹⁾	5	100	690	12.6	3x25	1x16	1x16	Cu	2.292	15410•
VKS 5/100 SS ⁽¹⁾	5	100	690	12.6	3x25	1x16	1x16	Cu	2.292	15415•
VKS 5/120 HS ⁽¹⁾	5	120	690	12.5	3x30	1x16	1x16	Cu	2.427	15411•
VKS 5/120 SS ⁽¹⁾	5	120	690	12.5	3x30	1x16	1x16	Cu	2.427	15416•
VKS 5/140 HS ⁽¹⁾	5	140 ⁽²⁾	690	11.3	3x35	1x16	1x16	Cu	2.549	15487•
VKS 5/140 SS ⁽¹⁾	5	140 ⁽²⁾	690	11.3	3x35	1x16	1x16	Cu	2.549	15655•
VKS 6/ 63 HS	6	63	690	11.5	3x16	1x16	2x16	Cu	2.202	15419•
VKS 6/ 63 SS	6	63	690	11.5	3x16	1x16	2x16	Cu	2.202	15424•
VKS 6/100 HS	6	100	690	12.6	3x25	1x16	2x16	Cu	2.436	15420•
VKS 6/100 SS	6	100	690	12.6	3x25	1x16	2x16	Cu	2.436	15425•
VKS 6/120 HS	6	120	690	12.5	3x30	1x16	2x16	Cu	2.571	15421•
VKS 6/120 SS	6	120	690	12.5	3x30	1x16	2x16	Cu	2.571	15426•
VKS 6/140 HS	6	140 ⁽²⁾	690	11.3	3x35	1x16	2x16	Cu	2.693	15260•
VKS 6/140 SS	6	140 ⁽²⁾	690	11.3	3x35	1x16	2x16	Cu	2.693	15656•

(1) VKS 5 eliminates conductor number 6; plastic housing however identical to VKS 6.

(2) 80% ED

(3) Section is superseded 6 mm at 20 °C UT.

(4) Same cross section at PE (ground) when used for control line. Other conductor combinations are possible.

(5) Not with UL-approval; UUL= 600 V

(6) For supply lengths above 4 m refer to restricted ambient temperature (page 3).

• Suffix types e.g. 2 m VKS 4/120 with PE R VKS 4/120-2 HS- Order No. 154012.

Shorter sections are made up from the next larger standard length.

X Only for conductor system without PE-marking

CURVED SECTIONS, JOINT MATERIAL

Curved sections⁽¹⁾

per your layout drawing

Max. L = 3.60 m, support spacing: ~ 500 mm, max. angle 180°



Curved sections⁽¹⁾

3-pole

Type	R mm	Surcharge Order No. VKS 3
Horizontal curve, right	400 - 900	150385
Horizontal curve, left	400 - 900	150386
Horizontal curve, right	>900	153120
Horizontal curve, left	>900	153130
Inside curve	200 - 800	150387
Inside curve	>800	153040
Outside curve	200 - 800	150388
Outside curve	>800	153050

Joint material

3-pole

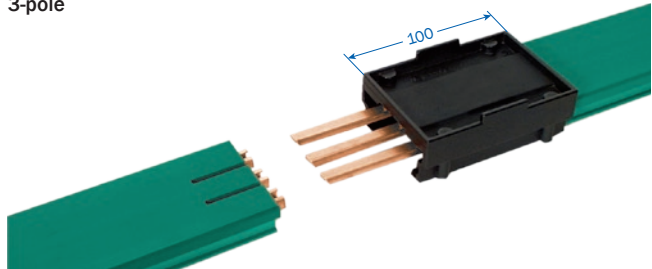

Type	No. of poles	Weight kg	Order No.
SVN 3/ 63 - 100	3	0.112	156533
SVN 3/120 - 140	3	0.112	156534

Curved sections⁽¹⁾

4-pole

Configuration as shown above

Type	R mm	Surcharge Order No. VKS 4
Horizontal curve, right	400 - 900	150389
Horizontal curve, left	400 - 900	150391
Horizontal curve, right	>900	153717
Horizontal curve, left	>900	150110
Inside curve	200 - 800	150392
Inside curve	>800	153718
Outside curve	200 - 800	150393
Outside curve	>800	150100

Joint material

4-pole

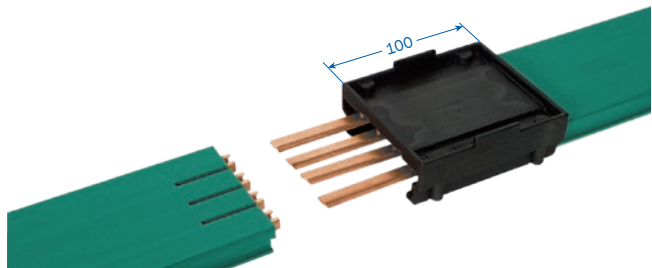

Type	No. of poles	Weight kg	Order No.
SVN 4/ 63 - 100	4	0.136	156535
SVN 4/120 - 140	4	0.136	156536

Curved sections⁽¹⁾

5- and 6-pole

Configuration as shown above

Type	R mm	Surcharge Order No.	
		VKS 5	VKS 6
Horizontal curve, right	400 - 900	150394	150398
Horizontal curve, left	400 - 900	150395	150399
Horizontal curve, right	>900	153719	153721
Horizontal curve, left	>900	152090	152110
Inside curve	200 - 800	150396	150401
Inside curve	>800	153720	153722
Outside curve	200 - 800	150397	150402
Outside curve	>800	152080	152100

Joint material

5- and 6-pole

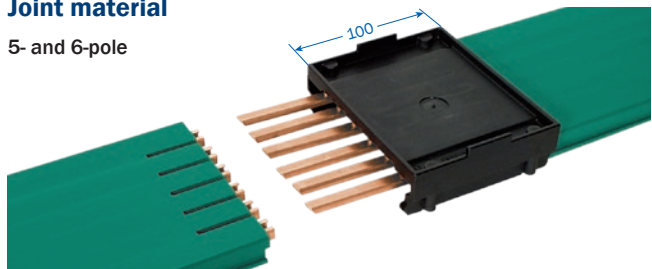

Type	No. of poles	Weight kg	Order No.
SVN 5/ 63 - 100	5	0.180	156537
SVN 5/120 - 140	5	0.180	156538
SVN 6/ 63 - 100	6	0.194	156539
SVN 6/120 - 140	6	0.194	156540

(1) Curved sections will be factory prepared with a 100 mm straight section on both ends. Horizontal curves with more than 90 degrees should be divided in two or more sections.

HANGERS, END CAPS

Fixpoint hanger⁽¹⁾

3-pole
with tapping screw and clamp

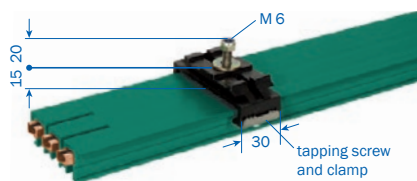

Type	Weight kg	Order No.
VEPS 3	0.042	153070

Sliding hanger⁽¹⁾

3-pole

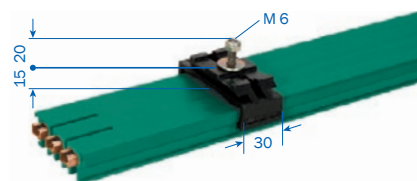

Type	Weight kg	Order No.
VAS 3	0.036	153060

End cap⁽²⁾

3-pole
suitable left and right

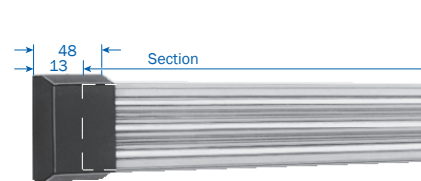

Type	Weight kg	Order No.
VES 3 - L	0.033	153080
VES 3 - M	0.033	152023

Fixpoint hanger⁽¹⁾

4-pole
with tapping screw and clamp

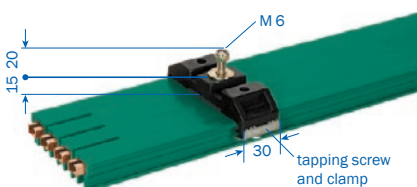

Type	Weight kg	Order No.
VEPS 4	0.046	150120

Sliding hanger⁽¹⁾

4-pole

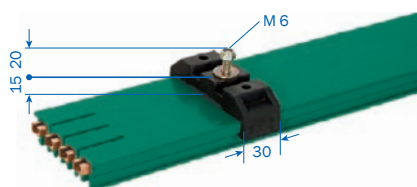

Type	Weight kg	Order No.
VAS 4	0.040	150130

End cap⁽²⁾

4-pole
suitable left and right

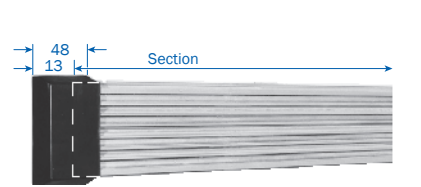

Type	Weight kg	Order No.
VES 4 - L	0.039	150140
VES 4 - M	0.039	152022

Fixpoint hanger⁽¹⁾

6-pole
with tapping screw and clamp

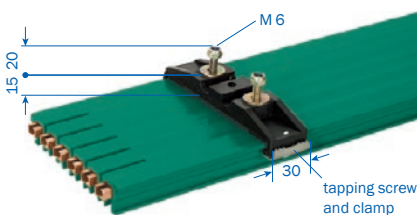

Type	Weight kg	Order No.
VEPS 6	0.062	152120

Sliding hanger⁽¹⁾

6-pole

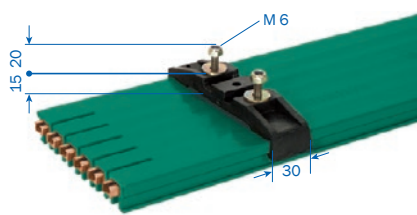

Type	Weight kg	Order No.
VAS 6	0.056	152130

End cap⁽²⁾

6-pole
suitable left and right

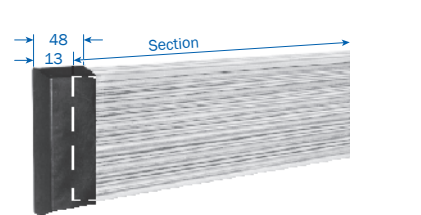

Type	Weight kg	Order No.
VES 6 - L	0.051	152140
VES 46 - M	0.051	152021

(1) Complete with hardware (bolts, nuts, spring washers). Support spacing see page 5.

(2) L = loose; c/w hardware
M = Factory assembled

FEEDS

End feed⁽¹⁾

3-pole
Terminal box with terminal clamps

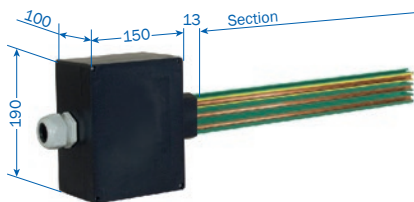

Type	Cable gland ⁽²⁾	Ampacity A	Weight kg	Order No.
VEKS 3/63 - 120 L	ST-M 40x1.5	63-120	1.150	156422
Surcharge for assembling				156423

End feed⁽¹⁾

4-pole
Terminal box with terminal clamps

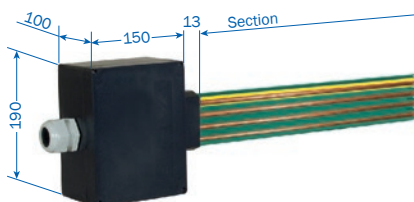

Type	Cable gland ⁽²⁾	Ampacity A	Weight kg	Order No.
VEKS 4/63 - 120 L	ST-M 40x1.5	63-120	1.230	156421
Surcharge for assembling				156423

End feed⁽¹⁾

5- and 6-pole
Terminal box with terminal clamps

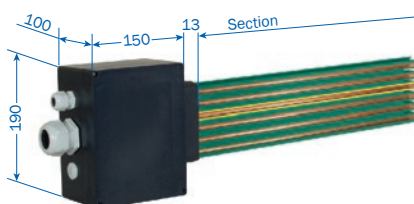

Type	Cable gland ⁽²⁾	Ampacity A	Weight kg	Order No.
VEKS 5/63 - 120 L	ST-M 40x1.5 ST-M 20x1.5	63-120	1.380	156420
VEKS 6/63 - 120 L	ST-M 40x1.5 ST-M 20x1.5	63-120	1.460	156419
Surcharge for assembling				156423

(1) End feeds loose as components. Sections are to be ordered separately (see page 6).

(2) Cable gland ST - M40x1,5 for $\varnothing = 19-28$ mm
ST - M20x1,5 for $\varnothing = 7-13$ mm

FEEDS

Line feed ⁽¹⁾

3-pole

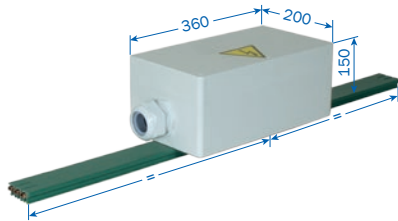

Type ⁽²⁾	Cable gland ⁽²⁾	Ampacity A	Weight kg	Order No.
VNS 3/63-140	STR-M63x1.5	63-140	1.876	157147

Line feed ⁽¹⁾

4-pole

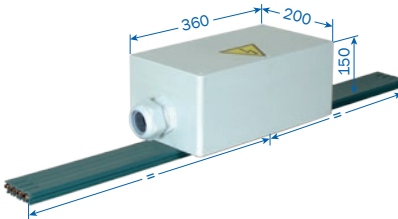

Type ⁽²⁾	Cable gland ⁽²⁾	Ampacity A	Weight kg	Order No.
VNS 4/63-140	STR-M63x1.5	63-140	1.982	157146

Line feed ⁽¹⁾

5- and 6-pole

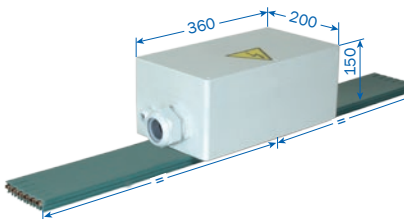

Type ⁽²⁾	Cable gland ⁽²⁾	Ampacity A	Weight kg	Order No.
VNS 5/63-140	STR-M63x1.5 STR-M20x1.5	63-140	2.080	157145
VNS 6/63-140	STR-M63x1.5 STR-M20x1.5	63-140	2.200	157144

Line feed ⁽¹⁾

3-pole

without cable connection; cable by others terminal bolt M 6

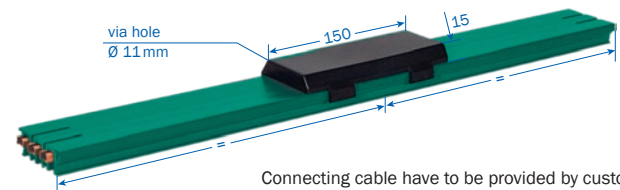

Type	Lug mm ²	Ampacity A	Weight kg	Order No.
VLS 3/ 63	-	63	0.071	156948
VLS 3/100-120 ⁽³⁾	25	100-120	0.137	156944
VLS 3/140 ⁽³⁾	35	140	0.173	156958

Line feed ⁽¹⁾

4-pole

without cable connection; cable by others terminal bolt M 6

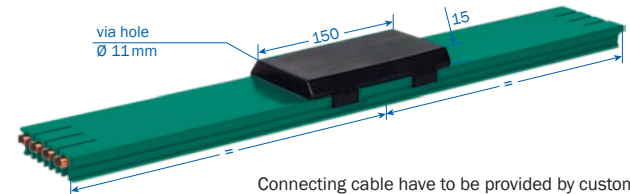

Type	Lug mm ²	Ampacity A	Weight kg	Order No.
VLS 4/ 63	-	63	0.091	156947
VLS 4/100-120 ⁽³⁾	25	100-120	0.179	156943
VLS 4/140 ⁽³⁾	35	140	0.227	156957

Line feed ⁽¹⁾

5- and 6-pole

without cable connection; cable by others terminal bolt M 6

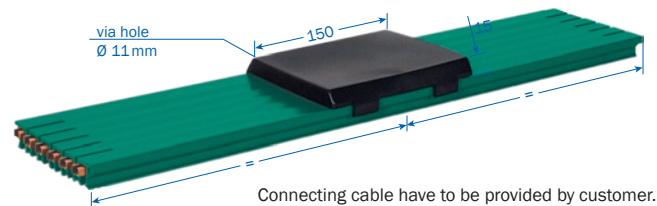

Type	Lug mm ²	Ampacity A	Weight kg	Order No.
VLS 5/ 63	-	63	0.115	156946
VLS 5/100-120 ⁽³⁾	25	100-120	0.225	156942
VLS 5/140 ⁽³⁾	35	140	0.285	156956
VLS 6/ 63	25	63	0.123	156945
VLS 6/100-120 ⁽³⁾	35	100-120	0.255	156941
VLS 6/140 ⁽³⁾	25	140	0.327	156955

(1) Line feeds will be normally installed on 1m sections. This sections have to be ordered separtly. (see page 6). Connecting cable by customer.

(2) Cable gland STR - M63x1.5 for Ø= 28-45 mm Cable connection main: M10
STR - M20x1.5 for Ø= 5-13 mm Cable connection control: M5

(3) Cable connection with attached special cable lugs for single cores 35 mm² (up to conductor-Ø 8.5 mm) for 140A, 25 mm² (up to conductor-Ø 8.2 mm) for 100-120A

TRANSFER GUIDES

Transfer guides⁽¹⁾

3-pole – for transfers, switches, spur lines
 Max. horizontal and vertical offset: ±2 mm
 Application: – straight cuts
 – oblique cuts, lateral



Photo shows left version

Type	Order No. Left version	Order No. Right version
VU 3 S-M	150191	150192
VU 3 S-L	150188	

Typ M: factory assembled;
 Typ L: ⁽²⁾ loose delivery as a single component, complete with accessories

Transfer guide oblique cut⁽¹⁾

3-pole – for switches and turntables
 prepared per your layout drawings
 Application: oblique cuts, horizontal

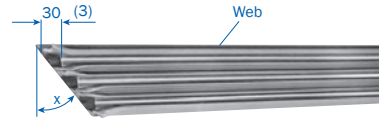

Photo shows left version

IP 21 up to x = 45°

Type	Order No. Left version	Order No. Right version
VUS 3 H	150410	150420

Transfer guide⁽¹⁾

4-pole – for transfers, switches, spur lines
 Max. horizontal and vertical offset: ±2 mm
 Application: straight cuts

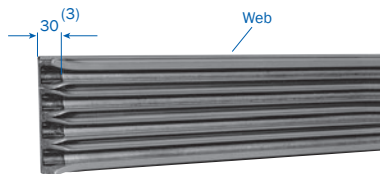

Photo shows left version

Type	Order No. Left version	Order No. Right version
VU 4	150160	150390

Transfer guide oblique cut⁽¹⁾

4-pole – for switches and turntables
 prepared per your layout drawings
 Application: oblique cuts, horizontal and lateral

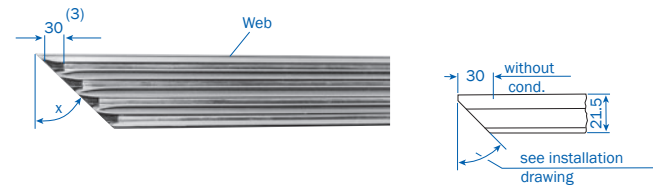

Photo shows left version

IP 21 up to x = 45°

Type	Order No. Left version	Order No. Right version
VUS 4 H	150170	150400
VUS 4 S	153564	153565

H = for horizontal mounting S = for lateral mounting (see page 6 and 7)

Transfer guide⁽¹⁾

6-pole – for transfers, switches, spur lines
 Max. horizontal and vertical offset: ±2 mm
 Application: – straight cuts
 – oblique cuts, lateral

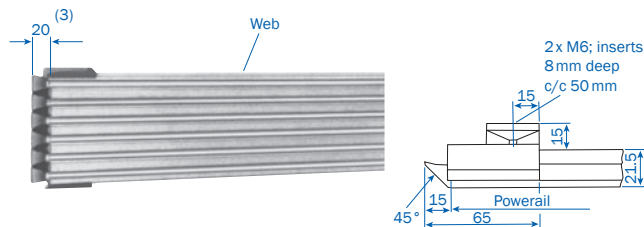

Photo shows left version for VKS 6 and VKS 5

Type	Order No. Left version	Order No. Right version
VU 6 S-M	153801	153802
VU 6 S-L	150215	

Typ M: factory assembled;
 Typ L: ⁽²⁾ loose delivery as a single component, complete with accessories

Transfer guide oblique cut⁽¹⁾

5- and 6-pole – for switches and turntables
 prepared per your layout drawings
 Application: oblique cuts, horizontal

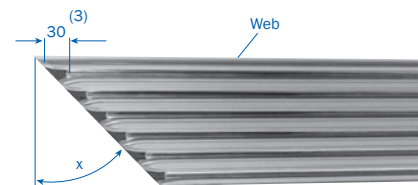

Photo shows left version

Type	Order No. Left version	Order No. Right version
VUS 5 H	152170	152300
VUS 6 H	152310	152320

(1) Fig. shows transfer and section. The section is included in the overall length. It will be charged separately for individual orders. (Specify type of conductor rail).
 (2) Preparation of conductor rail ends by others, following attached instructions. Please specify conductor type when ordering.
 (3) Length without conductors.

TRANSFER FUNNELS

Transfer funnels for KSTU 30/55

for max. speed $v = 100 \text{ m/min.}^{(2)}$

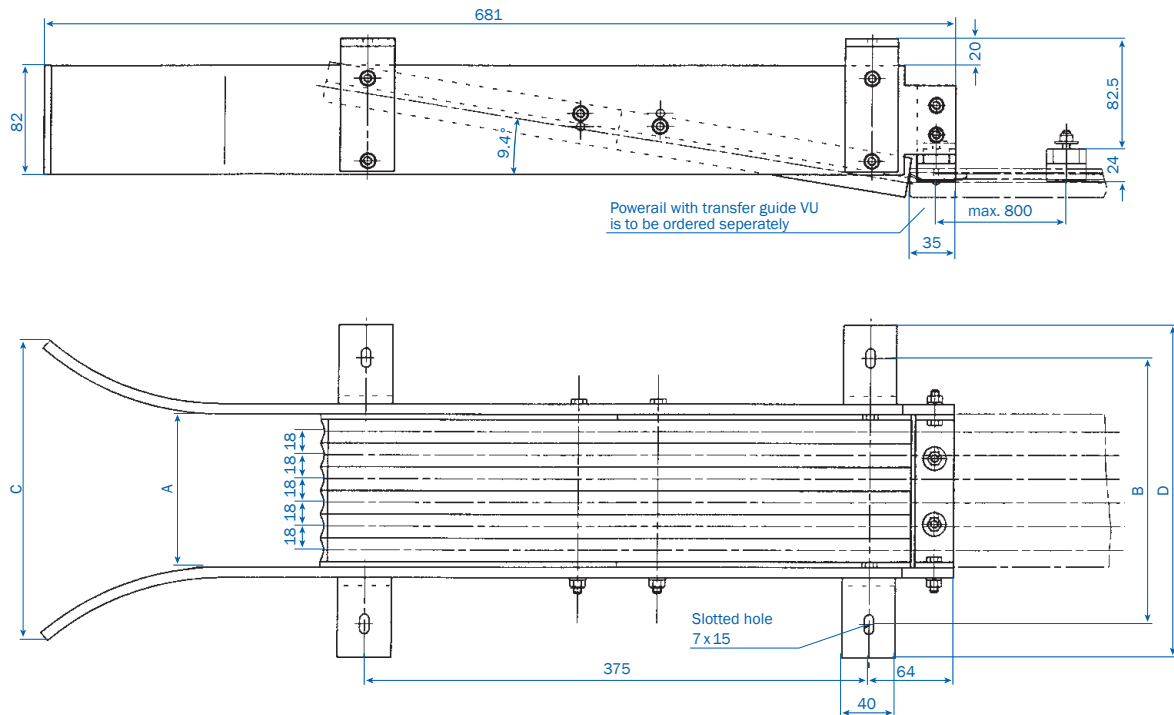

Type	A mm	B mm	C mm	D mm	Weight kg	Order No.	VU... L ⁽¹⁾	VU... R ⁽¹⁾
EFT V3 - KSTU	62	148	175	198	3.140	156144	150370	150380
EFT V4 - KSTU	80	166	193	216	3.320	156145	150160	150390
EFT V6 - KSTU	116	202	229	252	3.680	156146	152280	152290

(1) Conductor rail section must be factory prepared. Order separately for left hand VU...L, for right hand VU...R.

(2) Higher speeds on request

TRANSFER FUNNELS / EXPANSION SECTIONS

Transfer funnels for KSFU 25⁽¹⁾

for max. speed $v = 100 \text{ m/min.}^{(2)}$

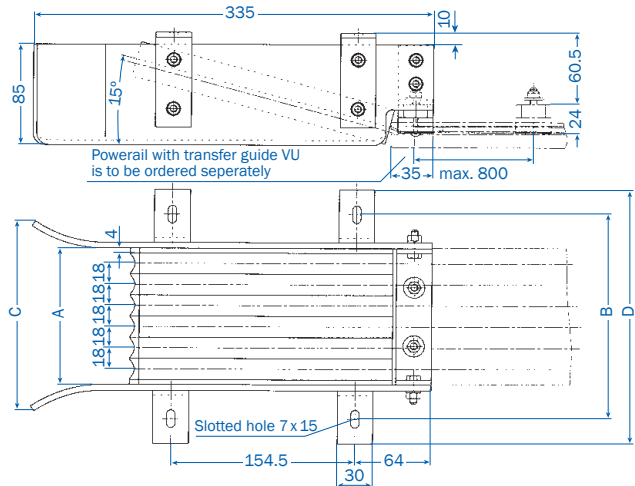

Type	A mm	B mm	C mm	D mm	Weight kg	Order No.	VU ... L ⁽¹⁾	VU ... R ⁽¹⁾
EFT V3 - KSFU 25	62	120	108	162	1.400	153337	150370	150380
EFT V4 - KSFU 25	80	138	126	180	1.520	153336	150160	150390
EFT V5 - KSFU 25	98	156	144	198	1.640	156132	152160	152270
EFT V6 - KSFU 25	116	174	162	216	1.760	153335	152280	152290

Expansion sections

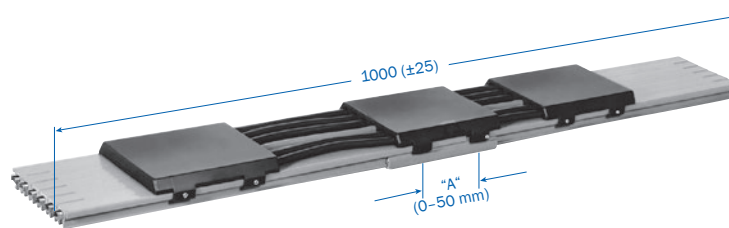

Type ⁽³⁾	Weight kg	Order No. (with PE) HS	Order No. (without PE) SS	Type ⁽³⁾	Weight kg	Order No. (with PE) HS	Order No. (without PE) SS
DVKS 3/ 63	1.900	153230	153240	DVKS 5/ 63	3.266	152340	152380
DVKS 3/ 100	2.090	153250	150551	DVKS 5/ 100	3.586	152350	150554
DVKS 3/ 120	2.215	153623	150552	DVKS 5/ 120	3.811	153633	150555
DVKS 3/ 140	2.346	156588	156589	DVKS 5/ 140	4.030	156596	156597
DVKS 4/ 63	2.412	150480	150510	DVKS 6/ 63	3.582	152360	152390
DVKS 4/ 100	2.622	150490	150516	DVKS 6/ 100	3.962	152370	150556
DVKS 4/ 120	2.852	153628	150553	DVKS 6/ 120	4.242	153638	150557
DVKS 4/ 140	3.027	156590	156595	DVKS 6/ 140	4.504	156598	156599

Application

Expansion sections are required to compensate for expansion and contraction in system expansion gaps (building or track). The expansion capacity is 50 mm. More tolerance require more than one VKS expansion section. They do not interrupt electrical power, so there is no need for an extra feeding. Expansion joints do not influence the voltage drop of a system.

Mounting

The expansion section is installed in the center between two fix points in the building/track expansion gap area. The gap dimension "A" equals the gap of the building/track. The remaining conductor rail is laid according to the installation instructions.

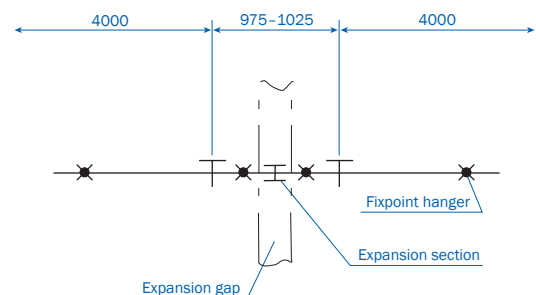

Sketch 1

(1) Conductor rail section must be factory prepared. Order separately for left hand VU ... L, or for right hand VU ... R.

(2) Higher speeds on request.

(3) Suffix types e.g. DVKS 3/10 with PE DVKS 3/60 HS Order No. 153230.

SECTIONALIZING / CURRENT COLLECTORS

Conductor dead section

The use of insulating section separations is limited to sectioning of equal potentials/voltages and low energies (e.g. control signals).

(1) Position of the conductor dead section and item number of the conductor profile which has to be separated have to be advised by ordering.

Type	Order No.	Colour
VSTS 1/10-63 M	156933	black
VSTS 1/100 M	150150	black
VSTS 1/120 M	151674	black
VSTS 1/140 M	156335	black

M = factory assembled

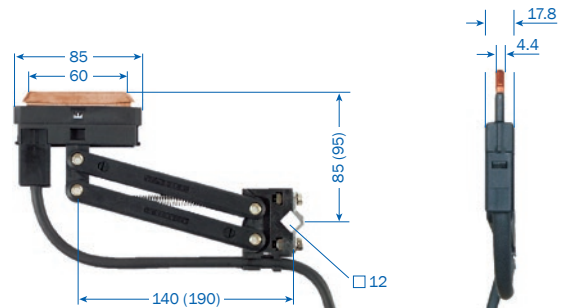
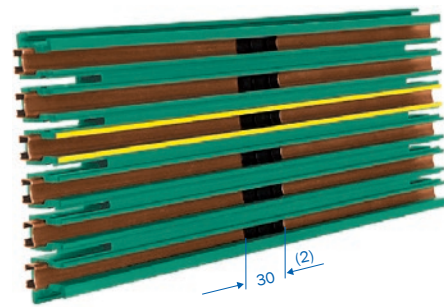

Collector

with 2 m connecting cable; contact pressure: ca. 5 N

For transfer funnels EFT V...-KSTU

(in funnel area ± 10 to all sides)

Type ⁽³⁾	Ampacity A	Connecting cable A/ mm ²	d max/ mm	Lift & Swivel deflection mm	Weight kg	Order No. Phase black	PE yellow
KSTU 30	30	2.50	5	± 20	0.240	152087	152088
KSTU 55	55	6.00	11	± 20	0.368	154441	154442

For double arrangement of current collectors and support spacing for conductor system see page 5.

Compact collector

with 1 m connecting cable for transfer funnel EFT V...-KSFU 25

(in funnel area ± 10 to all sides)

Max. ampacity: 25A

Phase distance: 18 mm

Lift and swivel deflection: ± 15 mm

Contact pressure: ca. 3.5 N per carbon

PE on No. 4, with 3-poles on No. 3, other arrangements possible

PE is first contact while entering conductor rail

Connecting cable cross section: 2.5 mm²

Connecting cable diameter: 4 mm

Type ⁽³⁾	Pol- es	a mm	b mm	Weight kg	Order No. with PE HS	without PE ST
KSFU 25-2	2	18	43	0.182	155050	155059
KSFU 25-3	3	54	79	0.295	155051	155060
KSFU 25-4	4	54	79	0.352	155052	155061
KSFU 25-5	5	80	115	0.460	155053	155062
KSFU 25-6	6	80	115	0.517	155054	155063
Separately available:					PH	PE
Collector KSFU 25					155025	155026

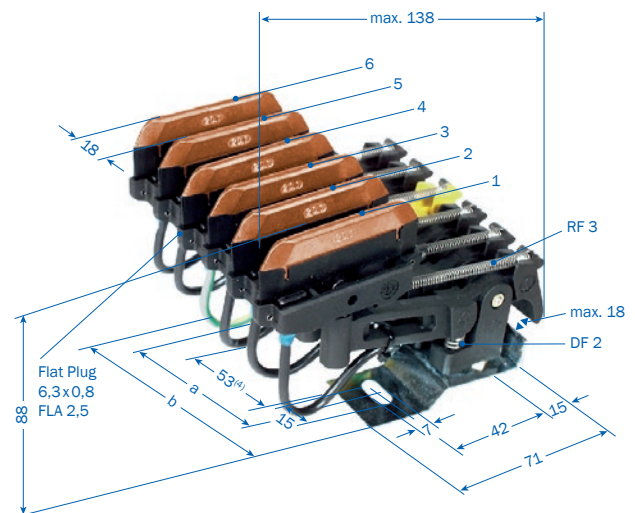

(1) Description of conductor profiles see page 8.

(2) Length of the currentless track (longer designs on request).

(3) Types to be completed e.g. KSTU 30 R KSTU 30 PH Order No. 152087

(4) Only with 5 and 6-pole version.

COMPACT COLLECTORS

Compact collector KESR 32-55

Two-way conveying

Max. ampacity: 1 flat plug connection 32 A – FLA 2,5
 40 A – FLA 4,0
 55 A – FLA 6,0

Phase distance 18 mm

Lift and swivel deflection ±15 mm

Contact pressure: ca. 7 N per carbon

PE on No. 4, with 3-poles on No. 3, other arrangements possible

PE is first contact while entering conductor rail

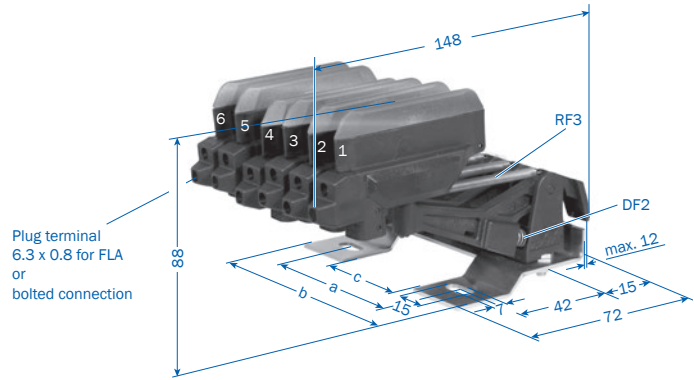

Choice of connecting cable see page 18

KESR 32-55 F (Flat plug connection)

Type ⁽¹⁾	Poles	a mm	b mm	c mm	Weight kg	Base plate	Order No.	
							with PE HS	without PE ST
KESR 32-55 F- 3-18	3	54	79	-	0.393	4 poles (No. 4 = free)	157285	157290
KESR 32-55 F- 4-18	4	54	79	-	0.457	4 poles	157286	157291
KESR 32-55 F- 5-18	5	80	115	53	0.521	6 poles (No. 6 = free)	157287	157292
KESR 32-55 F- 6-18	6	80	115	53	0.585	6 poles	157288	157293
Separately available:							Phase	PE
Collector KESR 32-55 F/18							157274	157275

KESR 32-55 S (Bolted connection)

Type ⁽¹⁾	Poles	a mm	b mm	c mm	Weight kg	Base plate	Order No.	
							with PE HS	without PE ST
KESR 32-55 S- 3-18	3	54	79	-	0.405	4 poles (No. 4 = free)	157220	157225
KESR 32-55 S- 4-18	4	54	79	-	0.476	4 poles	157221	157226
KESR 32-55 S- 5-18	5	80	115	53	0.547	6 poles (No. 6 = free)	157222	157227
KESR 32-55 S- 6-18	6	80	115	53	0.618	6 poles	157223	157228
Separately available:							Phase	PE
Collector KESR 32-55 S/18							157294	157295

Max. ampacity: 1 bolted connection 32 A – AEA 2,5 | 40 A – AEA 4,0 | 55 A – AEA 6,0

Adaptor for compact collectors

Type	Poles	a mm	b mm	c mm	Weight kg	Order No.
AD4 - KESR/KESL	4	79	35	54	0.210	157368
AD6 - KESR/KESL	6	115	65	80	0.310	157367
AD8 - KESR/KESL	8	151	100	120	0.410	157432



Ready assembled collectors including adaptor on request.

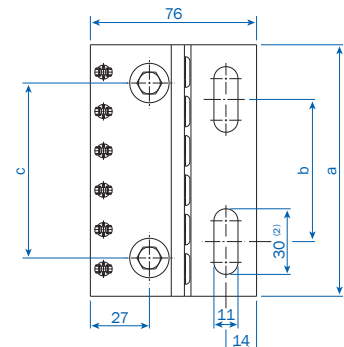
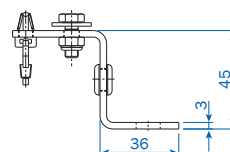
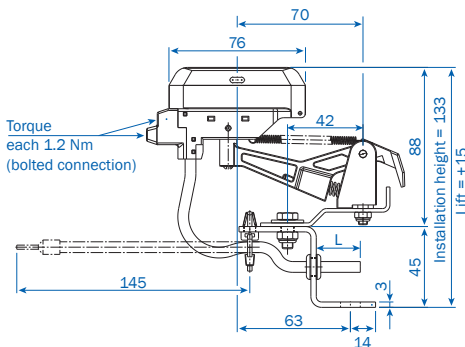

(1) Types to be completed e.g. KESR 32-55 S-4-18 with PE and bolted connection R KESR 32-55 S-4-18 HS Order No. 157221.
 (2) 25 at AD4 - KESR/KESL

COMPACT COLLECTOR

Compact collector KESL 32-55

Two-way conveying

Max. ampacity: 1 flat plug connection 32A – FLA 2,5
 40A – FLA 4,0
 55A – FLA 6,0

Phase distance 18mm

Lift and swivel deflection ± 30 mm

Contact pressure: ca. 7 N per carbon

PE on No. 4, with 3-poles on No. 3, other arrangements possible

PE is first contact while entering conductor rail

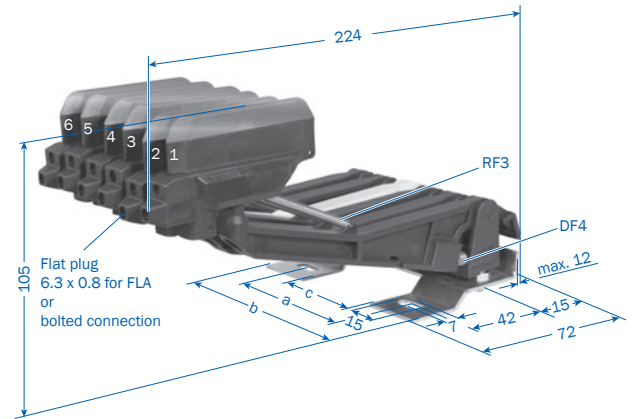

Choice of connecting cable see page 20

KESL 32-55 F (Flat plug connection)

Type ⁽¹⁾	Poles	a mm	b mm	c mm	Weight kg	Base plate	Order No.	
							with PE HS	without PE ST
KESL 32-55 F- 3-18	3	54	79	-	0.438	4 poles (No. 4 = free)	157199	157300
KESL 32-55 F- 4-18	4	54	79	-	0.517	4 poles	157200	157301
KESL 32-55 F- 5-18	5	80	115	53	0.596	6 poles (No. 6 = free)	157201	157302
KESL 32-55 F- 6-18	6	80	115	53	0.675	6 poles	157202	157303
Separately available:							Phase	PE
Collector KESL 32-55 F/18							157188	157189

KESL 32-63 S (Bolted connection)

Type ⁽¹⁾	Poles	a mm	b mm	c mm	Weight kg	Base plate	Order No.	
							with PE HS	without PE ST
KESL 32-63 S- 3-18	3	54	79	-	0.451	4 poles (No. 4 = free)	157190	157296
KESL 32-63 S- 4-18	4	54	79	-	0.537	4 poles	157191	157297
KESL 32-63 S- 5-18	5	80	115	53	0.623	6 poles (No. 6 = free)	157192	157298
KESL 32-63 S- 6-18	6	80	115	53	0.709	6 poles	157193	157299
Separately available:							Phase	PE
Collector KESL 32-63 S/18							157186	157187

Max. ampacity: 1 bolted connection 32A – AEA 2,5 | 40A – AEA 4,0 | 55A – AEA 6,0 | 63A – AEA 10,0

Adaptor for compact collectors

Type	Poles	a mm	b mm	c mm	Weight kg	Order No.
AD4 - KESR/KESL	4	79	35	54	0.210	157368
AD6 - KESR/KESL	6	115	65	80	0.310	157367
AD8 - KESR/KESL	8	151	100	120	0.410	157432



Ready assembled collectors incl. adapter on request.

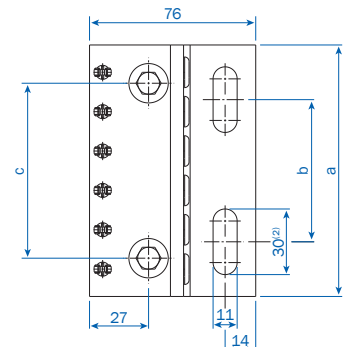
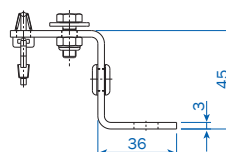
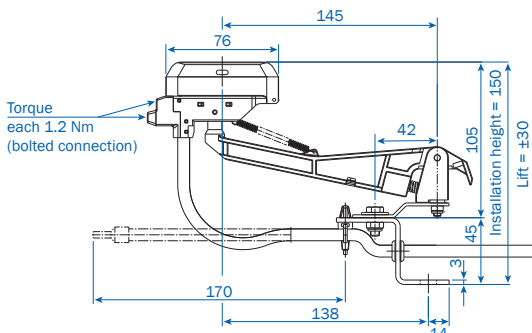

(1) Types to be completed e.g. KESL 32/63 with PE and bolted connection R KESL 32-63 S-4-18 HS Order No. 157191.
 (2) 25 at AD4 - KESR/KESL

ACCESSORIES FOR COLLECTOR

Connecting cable FLA

High flexible for collectors with flat plug connection

(Arrangement to different collector types according to pages 16 and 17.)

Operating conditions -15°C bis 70°C

L = 1 m with flat plug 6.3x0.8

Longer connection cables available.



Table 1

Type	Cross section mm ²	Outer-Ø mm	Wgt. kg	Order No. Phase black	PE green/ yellow
FLA 2,5	2.50	4.00	0.080	165049	165050
FLA 4	4.00	6.00	0.100	165051	165052
FLA 6	6.00	7.00	0.150	166368	166369

Connecting cable AEA

High flexible for collectors with Bolted connection

(Arrangement to different collector types according to pages 16 and 17.)

Operating conditions -15°C bis 70°C

L = 1 m with wire ferrules

Longer connection cables available.



Table 2

Type	Cross section mm ²	Outer-Ø mm	Wgt. kg	Order No. Phase black	PE green/ yellow
AEA 2,5	2.50	4.00	0.038	143080	143079
AEA 4,0	4.00	6.00	0.063	143078	143077
AEA 6,0	6.00	7.00	0.085	143076	143075
AEA 10,0	10.00	8.50	0.160	143074	143073

Towing arm

for current collectors

KSTU 30/55 see page 15

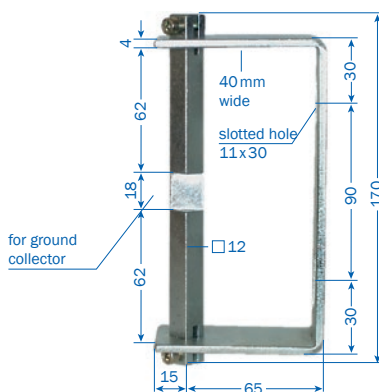

Collector with PE

Type	Weight kg	Order No.
UMAS 12 HS-B	0.600	152232

for control collectors

KSTU 30/55 see page 15

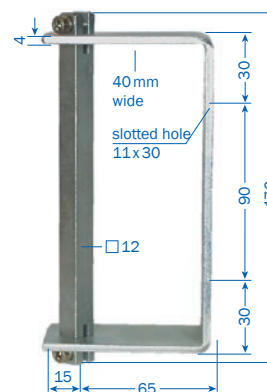

Collector without PE

Type	Weight kg	Order No.
UMAS 12 ST	0.600	152234

SPARE PARTS FOR COLLECTORS

Brushes

KMK 30-55 PH

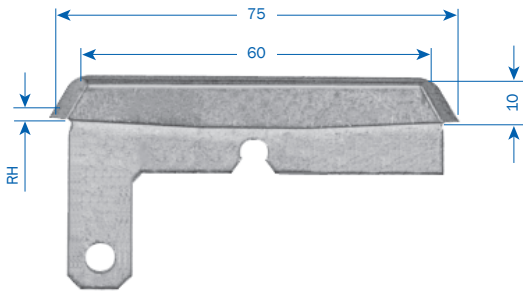

KMK 30-55 PE

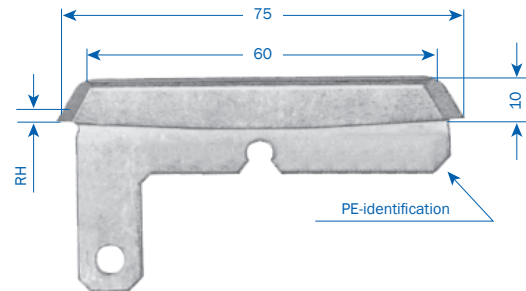

KMKU 25/18⁽¹⁾

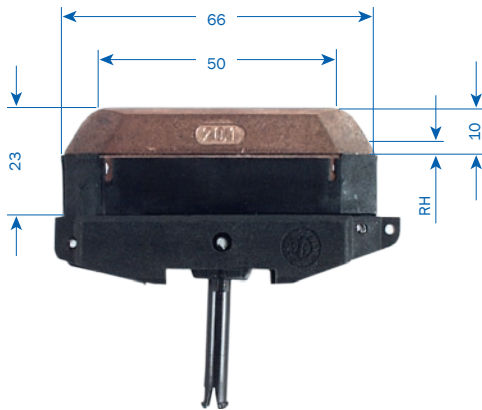

MK 55, MK 63

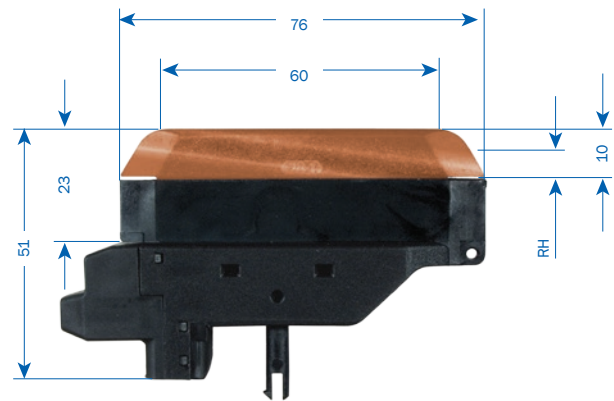

Type	For collectors	Thickness of brush	RH mm	Weight kg	Order No.
KMK 30-55 PH	KSTU 30-55	4.40 mm	4.00	0.031	154440
KMK 30-55 PE	KSTU 30-55	4.40 mm	4.00	0.034	154453
KMKU 25/18	KSFU 25	4.20 mm	3.50	0.035	155002
MK 55 F/18	KESR 32-55 F, KESL 32-55 F	4.20 mm	3.50	0.044	157308
MK 63 S/18	KESR 32-55 S, KESL 32-63 S	4.20 mm	3.50	0.053	157309

Dimension RH = allowed rest height

(1) 18 mm wide

SPARE PARTS

Springs

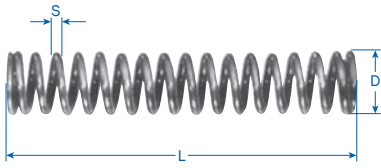

Pressure spring DF

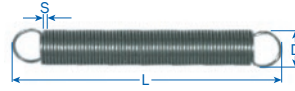

Tension spring RF

Type	For collectors	S mm	D mm	L mm	Order No.
DF 2	KSFU25, KESR 32-55	0.90	7.70	43.00	153848
RF 3	KSFU 25, KESR 32-55, KESL 32-63	0.40	4.40	31.00	153849
DF 4	KESL 32-63	1.10	6.40	41.00	157312

Spare parts

Type	Order No.
Joint cap for VKS 3	152012
Joint cap for VKS 4	152013
Joint cap for VKS 5 und 6	152014
Plug-in connector (1 pole, copper) for VKS.../ 10-100A	153803
Plug-in connector (1 pole, copper) for VKS.../120-140A	152672
Insulating piece for sectionalizing (1 pole) VSTS 1/63 L	156934
Insulating piece for sectionalizing (1 pole) VSTS 1/100 L	150419
Insulating piece for sectionalizing (1 pole) VSTS 1/120 L	151669
Insulating piece for sectionalizing (1 pole) VSTS 1/140 L	156336
Feed terminal, (1 pole) for line feed VNS	151774
Feed terminal, (1 pole) for line feed VLS	153603

SPARE PARTS FOR COLLECTORS

Collector KSTU 30-55

Type	Order No.		Weight kg	Order No.
1	Brush	Phase	0.031	154440
2	Brush	PE	0.031	154453
3	Collector arm KSTU, complete	Phase	0.083	152275
4	Collector arm KSTU, complete	PE	0.083	152276
5	Cover cap	Phase (black)	0.002	152291
6	Cover cap	PE (green)	0.002	152292
7	Distance spacer for KSTU 30-55		0.003	152293
8	Connecting cable RKA 2,5 PH, 2 m long	Phase	0.150	154447
	Connecting cable RKA 2,5 PE, 2 m long	PE	0.150	154448
8	Connecting cable RKA 6 PH, 2 m long	Phase	0.260	154449
	Connecting cable RKA 6 PE, 2 m long	PE	0.260	154450
9	Connecting screw		0.002	152658

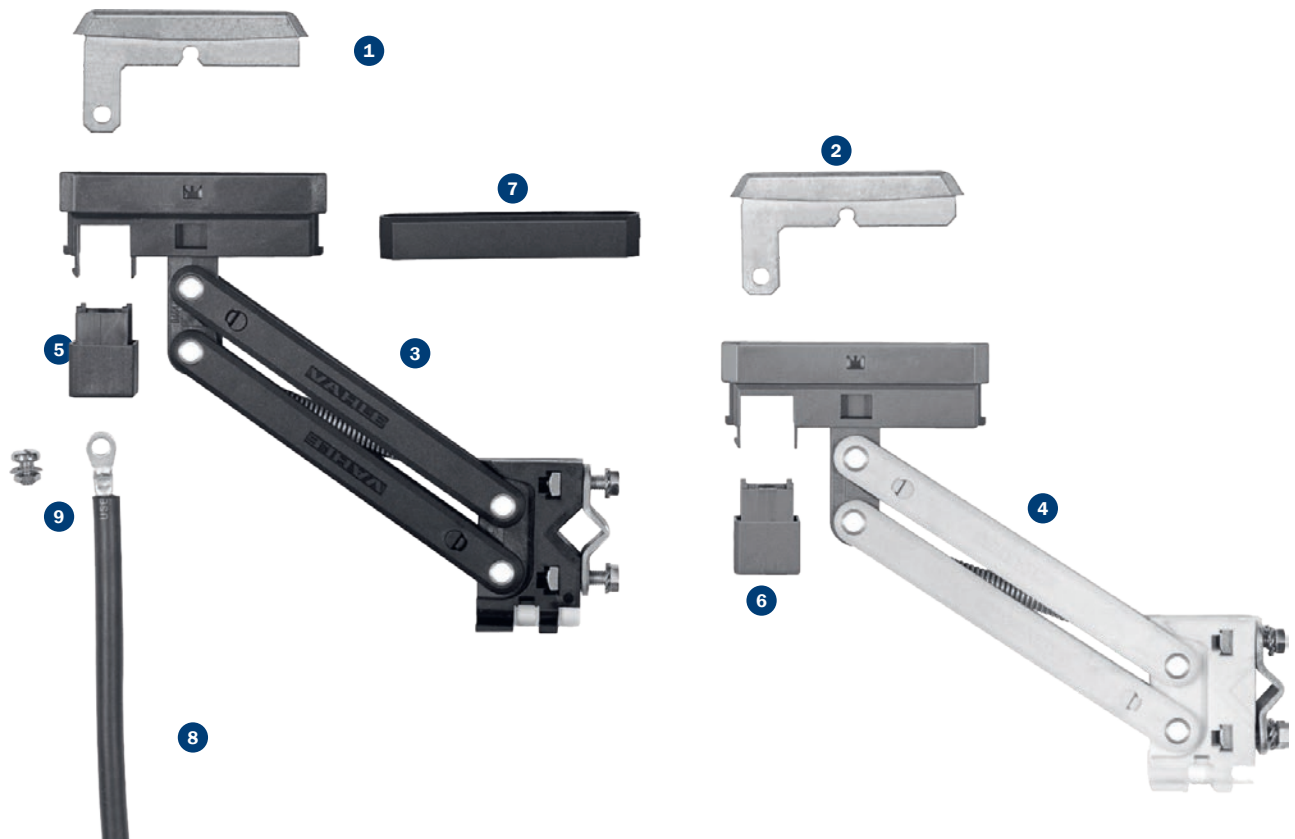

BRACKETS AND SNAP-ON BRACKETS

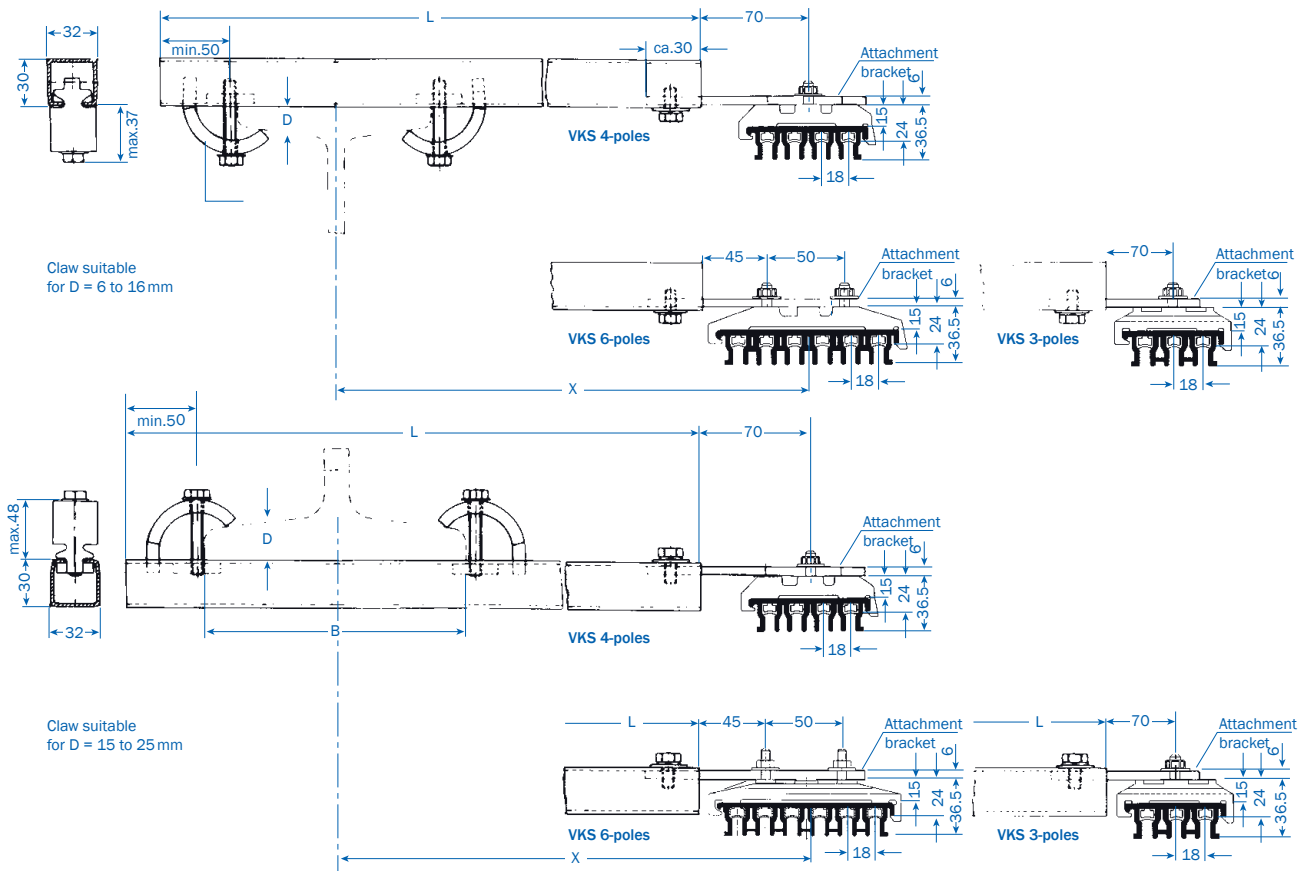

Attention!

Make sure that hoist wheels of monorail systems have enough clearance.

C-rail of HKV is identical to type S1 for cable carriers (catalog 8a).

Hangers to be ordered separately.

The corresponding beam width (B_{max}) could be enlarged by a reduction of X.

Type ⁽¹⁾	x mm	L mm	B _{max} mm	Weight kg	Order No.
HK ... 200	200	300	90	0.920	150600
HK ... 250	250	350	180	0.970	150610
HK ... 300	300	400	230	1.020	150620
HK ... 400	400	500	230	1.120	150630
HK ... 500	500	600	230	1.220	150640
HK ... 600	600	700	230	1.320	150650
HK ... 700	700	800	230	1.420	150660
HK ... 750	750	850	230	1.470	150670
HK ... 800	800	900	230	1.560	150680

Snap-on brackets

Snap-on brackets facilitate installation of conductor system on flat flange beams IPE-, IPB-, IPBI- and IPBV. They are adjustable to suit beam flange dimensions (tg) of up to 43 mm.

Type	AKL
Beam flange tg/mm	8-13 14-19 20-25 26-31 32-37 38-43
Weight/kg	0.184
Order No.	151925

Hangers for conductor system to be ordered separately.

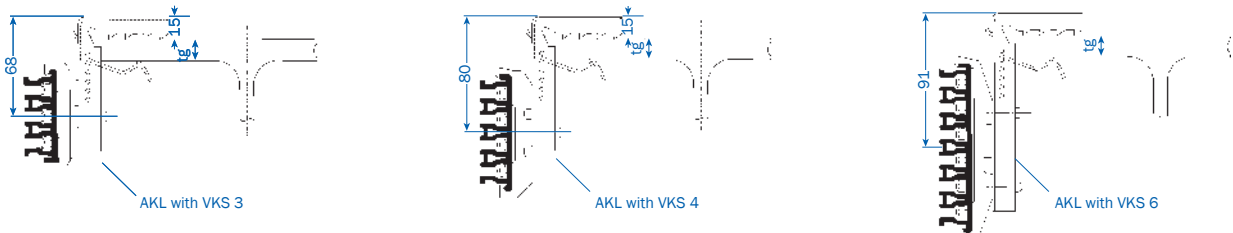

(1) Please complete types e.g. for VKS R HKVKS 200

OPTIMIZED SUPPORT STRUCTURE FOR THE VKS

The VAHLE Multi Carrier (VMT) is the optimum support structure when it comes to the fast and cost-effective assembly and modification of our conductor systems. In addition to accommodating the various conductor systems, positioning systems can of course also be integrated.

- Suspension distance up to 3.5 m possible
- Quick and easy assembly due to plug-in and clamping technology
- Universal suspension for all common upright profiles
- Mechanical protection of the conductor system
- Integration of optical positioning systems

Further information can be found in our VMT catalog (3c).

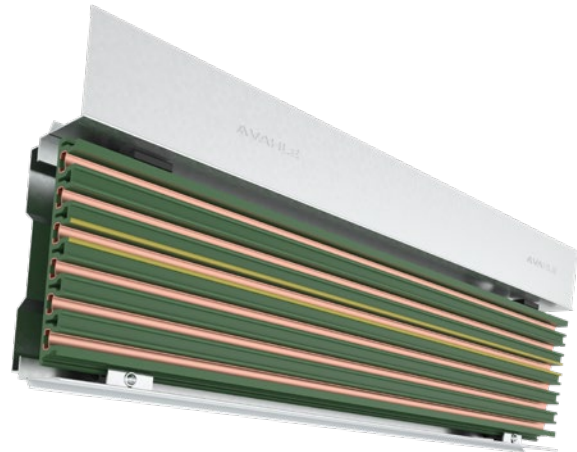

EXAMPLES FOR ORDERING

Straight track with end feed⁽¹⁾

12m VKS 3/100

Layout VKS

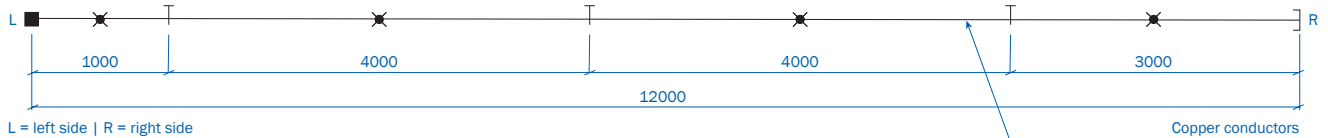

Qty	Description	Type	Order No.
2	Conductor rail, 4 m long	VKS 3/100-4 HS	153904
1	Conductor rail, 3 m long	VKS 3/100-3 HS	153903
1	Conductor rail, 1 m long	VKS 3/100-1 HS	153901
3	Joint material	SVN 3/63-100	156533
4	Fixpoint hanger	VEPS 3	153070
10	Sliding hangers	VAS 3	153060
1	End cap	VES 3	153080
1	End feed	VEKS 3/10-120 L	156422
1	Collector	KESR 32-55F-3-18 HS	157285
-	Tow arm	-	-
14	Support bracket	HKVKS 300	150620

(1) Layout symbols see page 5

EXAMPLE FOR ORDERING

Curved track with switch (lateral mounting)⁽¹⁾

27.857 m VKS 6/63 HS

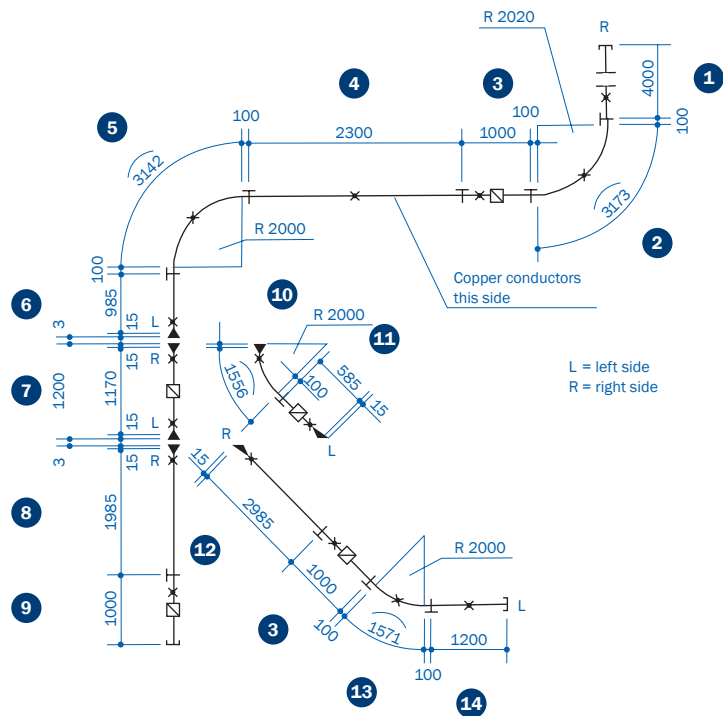

Qty	Description	Type	Order No.	Position
1	Conductor rail, 4 m long	VKS 6/63-4 HS	154194	1
2	Conductor rail, 3 m long cut to: 1x 2.985 m 1x 2.300 m	VKS 6/63-3 HS	154193	12 4
3	Conductor rail, 2 m long cut to: 1x 1.985 m 1x 1.200 m 1x 1.170 m	VKS 6/63-2 HS	154192	8 14 7
3	Conductor rail, 1 m long	VKS 6/63-1HS	154191	3 9
2	Conductor rail, 1 m long cut to: 1x 0.985 m 1x 0.585 m	VKS 6/63-1 HS	154191	6 11
2	Conductor rail, 4 m long 1x for outside curve 90°; R = 2020 mm; L = 3.373 m 1x for inside curve 90°; R = 2000 mm; L = 3.342 m	VKS 6/63-4 HS	154194	2 5
2	Conductor rail, 2 m long 1x for inside curve ~ 45°; R = 2000 mm; L = 1.656 m 1x for inside curve 45°; R = 2000 mm; L = 1.771 m	VKS 6/63-2 HS	154192	10 13
1	Bending surcharge (outside curve)		152100	
3	Bending surcharge (inside curve)		153722	
10	Joint material	SVN 6/63-100	156539	
16	Fixpoint hangers	VEPS 6	152120	
22	Sliding hangers	VAS 6	152130	
3	End caps on above position. 1, 9, 14	VES 6-M	152021	
2	Line feeds installed on position 3, 7, 9, 11	VLS 6/63	156945	
3	Transfer guides, left installed on Pos. 6, 7, 11	VU 6 S-M	153801	
4	Transfer guides, right installed on Pos. 7, 8, 10, 12	VU 6 S-M	153802	
1	Compact collector, Ground on No. 3	KESR 32-55S-6-18 HS	157223	

(1) Layout symbols see page 5.

QUESTIONNAIRE

Company: _____ Date: _____

Phone: _____ Fax: _____

Email: _____ Website: _____

1. Number of conductor system installations: _____
2. Type of equipment to be powered: _____
3. Operating voltage: _____ Volt Frequency: _____ Hz
 Three-phase voltage AC voltage DC voltage
4. Track length: _____
5. Number of conductors: _____ neutral: _____ control: _____ ground: _____
6. Mounted position of conductor system:
 Conductor system pendant, collector cable facing to the bottom Conductor system pendant, lateral payout of conductor cable⁽¹⁾
 Support distance _____ m (max. 2 m) Other: _____
7. Number of consumers per system: _____
8. Indoor system Outdoor system
9. Other operating conditions (humidity, dust, chemical influence, etc.) _____
10. Ambient temperature: _____ °C min. _____ °C max.
11. Hall expansion joints _____ pieces _____ expansion max.
12. Position and number of feeding points⁽¹⁾: _____
13. Position and number of isolating sections (e.g. for maintenance)⁽¹⁾: _____
14. How will the conductor be arranged?⁽¹⁾: _____
15. Brackets required: Yes No c/c distance beam/conductor system: _____
16. Travel speed: _____ m/min. in curves: _____ m/min. at transfers: _____ m/min.
17. Max. voltage drop from the conductor system feed point to the consumer considering starting current. _____
18. Power consumption of the individual consumer loads: _____

Motor data	Crane 1						Crane 2							
	Power kW	Nominal current			Starting current		Type of motors ⁽²⁾	Power kW	Nominal current			Starting current		Type of motors ⁽²⁾
		A	cos φ _N	% duty	A	cos φ _A			A	cos φ _N	% duty	A	cos φ _A	
Hoist motors														
Auxiliary hoist														
Long travel														
Cross travel														

Mark with * those motors which can run simultaneously.

Mark with Δ those motors which can start up simultaneously.

Further remarks: _____

Signature: _____

(1) For curved tracks, conductor system with isolating sections etc., we require sketches to enable us to prepare a quotation

(2) Use: K for squirrel cage motor, S for slipring motor, F for frequency controlled motor

We reserve all rights to make alterations in the interests of further development
Please copy and fill in the questionnaire.

NOTES

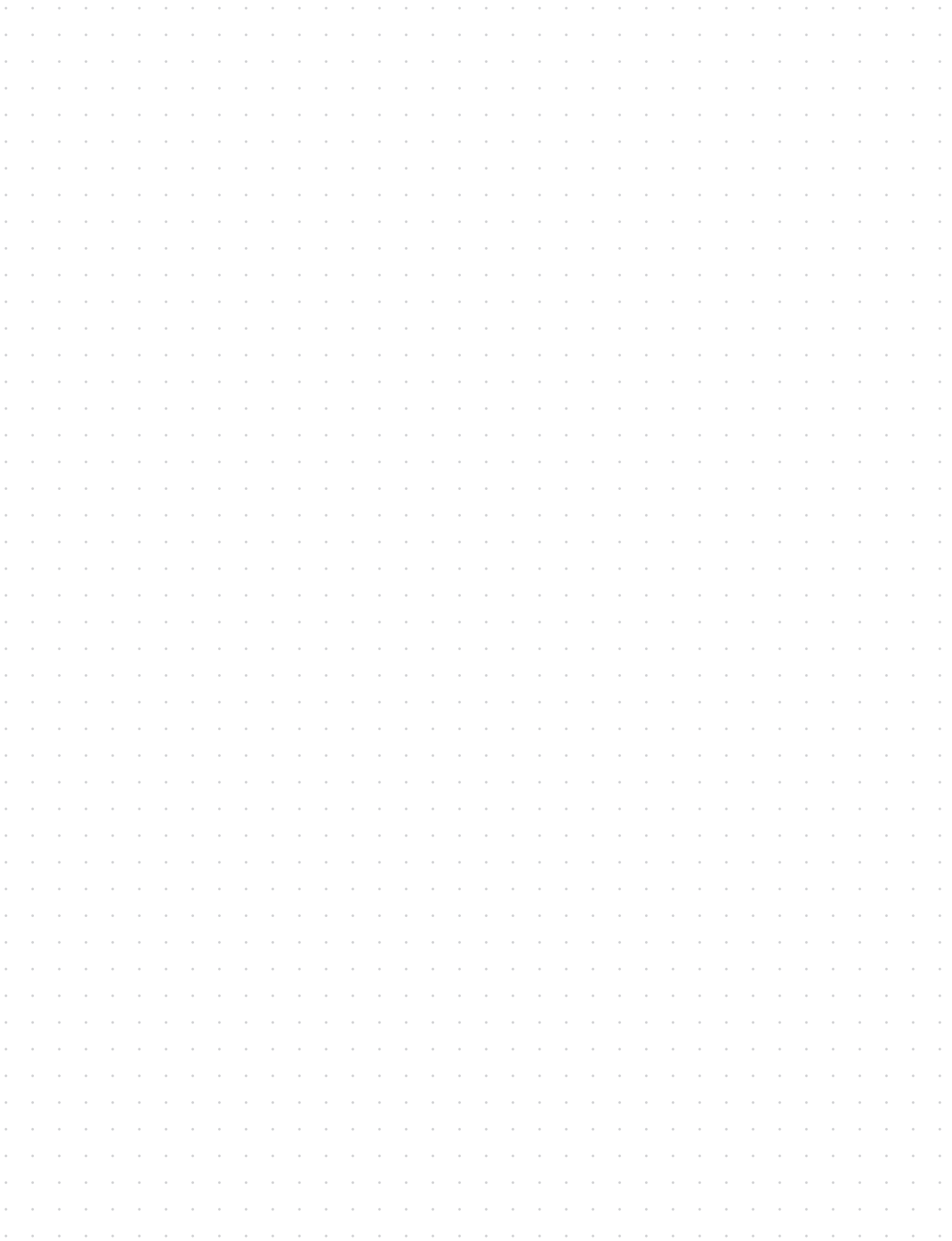

NOTES

A large grid of small dots for taking notes, consisting of 20 columns and 30 rows of dots.



Paul Vahle GmbH & Co. KG

Westicker Str. 52
59174 Kamen
Germany

+49 2307 7040
info@vahle.com
vahle.com

You can find your local contact at:

vahle.com/contact