



VAHLE COMPACT LINE VCL



DYNAMIC WAREHOUSE TECHNOLOGY

The high level of growth in intralogistics requires greater flexibility in warehouse technology with increasingly dynamic warehouse solutions. Online trade is booming and the diversity of products is increasing while the unit quantities tend to become smaller. This is where shuttle systems and automated small parts warehouses are gaining increasing popularity. Due to its modular design, the new VCL (VAHLE COMPACT LINE) conductor system is the perfect solution for the power supply of your application.

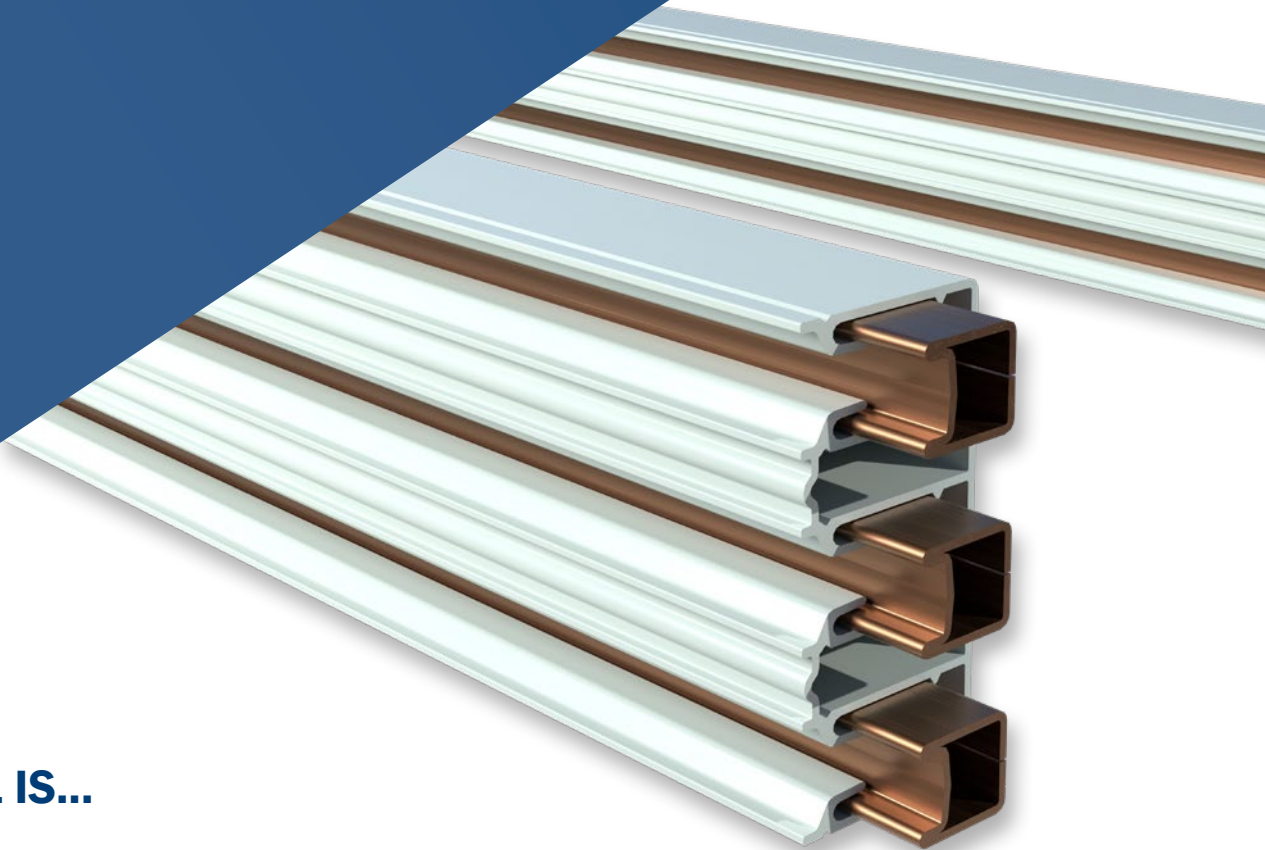

THE VCL IS...

VARIABLE

Universal solutions for all track-guided vehicles in warehouse technology

MODULAR

2- to 6-pole modular combinations can be realized

PLUG & PLAY

Safe, quick and easy installation using clip hangers and plug connectors

HIGH-PERFORMANCE

2 conductor versions for 40 and 100A continuous current and 12–500 V operating voltage

SAFE

Contact protected according to IP2X

UNIVERSAL

Installation options for all common warehouse technology profiles

TESTED

UL-approved

NO LIMITS

Suitable for highly dynamic high-speed applications

THE NEW VCL SYSTEM

THE MODULAR ALL-IN-ONE SOLUTION FOR YOUR WAREHOUSE TECHNOLOGY APPLICATION

The new VCL (VAHLE COMPACT LINE) compact conductor system is available as a two- or three-pole version and offers maximum flexibility. Combining these two conductor rails allows up to 6-pole conductor systems to be realized, which are extremely versatile. In addition to the power supply for the shuttle technology, the VCL is also ideally suited for use in SPW and pallet AS/RS applications as well as other compact moving and transfer cars applications in the small and medium power range up to 100 A.

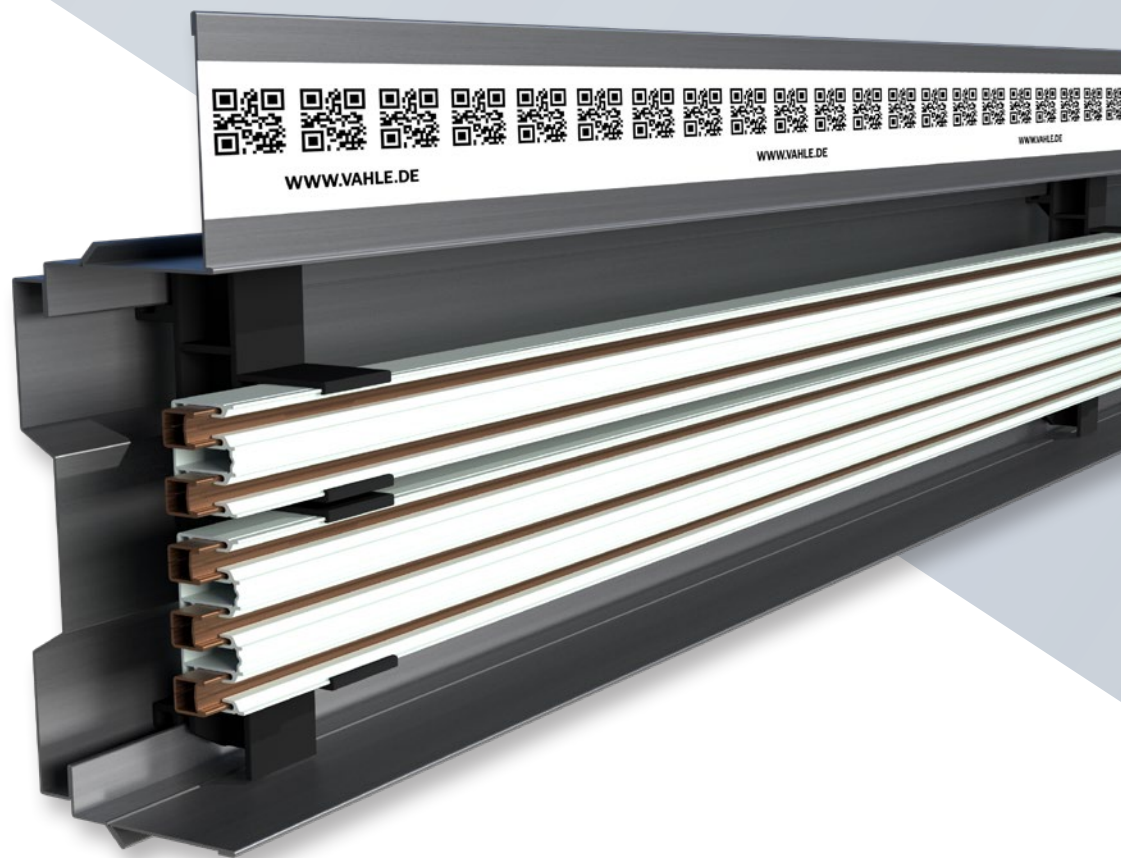
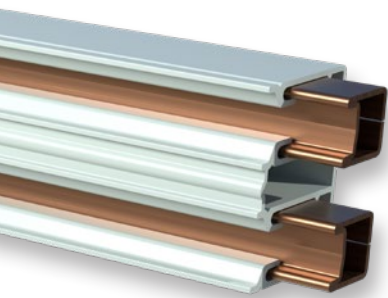

VAHLE VMT MULTI SUPPORT PROFILE

The VAHLE COMPACT LINE can be perfectly integrated into the proven VAHLE VMT multi support profile and offers all system features required for use in high-bay warehouses:

- Quick and easy installation using plug and clamping systems on all standard upright profiles
- Mechanical protection of the conductor system
- Integration of optical travel sensor and positioning systems



VCL FOR SHUTTLE APPLICATIONS



Shuttle systems permit extremely fast transport of materials and products with rapid handling times. Leading manufacturers of shuttle systems need specific solutions to meet these requirements. Thanks to clever mounting solutions, the highly compact VCL from VAHLE can be quickly and easily integrated into your guide profile. It has been designed for the high speeds and intensive usage cycles of shuttle systems.

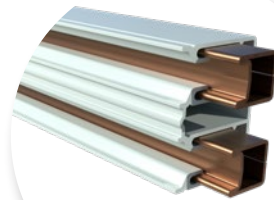

2-POLE

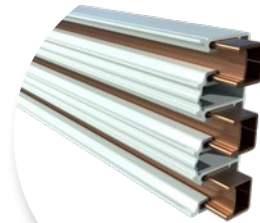

3-POLE

VCL 2 | VCL 3

Whether it is for single-level, multi-level or multi-shuttle vehicles of all sizes, the VCL, in 2- or 3-pole design, stands out for its ultra-compact design.

YOUR BENEFITS:

- Individually adaptable to your application by means of compact hangers
- Various combinations and mounting solutions
- Simple and fast plug & play installation with just a few components
- Suitable for highly dynamic high-speed applications
- The extremely compact design allows installation within a shuttle travel profile

SIMPLE INSTALLATION



Clip the hanger onto the support profile

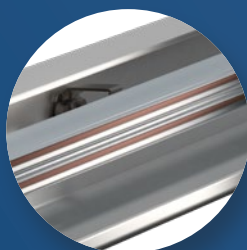

Insert VKL 2 profile

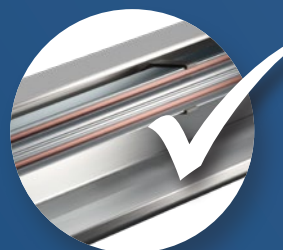

No tools required

VCL FOR STORAGE AND RETRIEVAL SYSTEMS



Speed and efficiency are essential if you intend to achieve maximum handling volume. Both automatic small parts warehouses and automatic pallet warehouses come into their own when a large number of items is stored and handled on limited space in multi-shift operation (up to 24/7). Safe and reliable energy supply to the storage and retrieval systems or transfer carriages is indispensable in this respect.

Due to its modular concept, the VCL is ideally suited for use in almost all of your warehouse areas. The VCL stands out for its compact design and simple and quick installation.

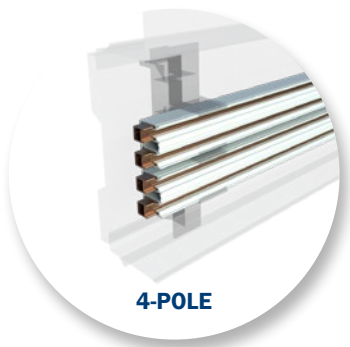

4-POLE



5-POLE



6-POLE

VCL 4 | VCL 5 | VCL 6 FOR VMT

By combining a two- and three-pole VCL, the compact conductor system can also be used in automatic small parts warehouses or even in pallet warehouses. Easily and quickly installed in the VAHLE VMT support profile, this variant stands out for its wide hanger spacing, perfect system protection and great variability for all warehouse technology mounting profiles.

YOUR BENEFITS:

- The modular system offers a wide range of solutions for various applications, 4-/6-pole / 40-100A / 12-500V
- Simple, fast and largely tool-free installation with just a few components
- Various combinations and mounting solutions (screw and clamping consoles for all common upright profiles)
- Safe mechanical protection of the conductor system by support profile
- Large support distance up to 3.5 meters
- Integration of optical travel sensor and positioning systems
- Ideal for high-speed applications



TECHNICAL SPECIFICATIONS VCL2 | VCL3

INSULATION PROFILE VALUES (ELECTRICAL)

Dielectric strength according to DIN 53481	Volume resistivity according to IEC 60093	Surface resistance according to IEC 60093	Comparative tracking index according to IEC 60112	Service temperature*	Flammability
>22.4 kV/mm	>8x10 ¹⁵ Ohm x cm	2 x 10 ¹³ Ohm x cm	CTI > 400	-30 °C to +55 °C	Flame-retardant, self-extinguishing, UL 94 V0

INSULATION PROFILE VALUES (MECHANICAL)

Type	Conductor cross section mm ²	Creepage distance of insulation mm	max. voltage V	max. continuous current A 100% duty cycle	Resistance ohm/1000 m	Impedance*** ohm/1000 m
VCL2/100 C** VCL3/100 C**	25	32	48 V AC/DC 500 V AC	100	0.721	0.723
VCL2/40 F** VCL3/40 F**	25	32	48 V AC/DC 500 V AC	40	3.844	3.846

SUPPLIED LENGTH

4 m standard length,
shorter sections are available

SUPPORT DISTANCE

0.8 m for installation in straight line

PHASE SPACING

15 mm

APPLICATION

Only for indoor systems

STRAIGHT SECTION, 2-POLE

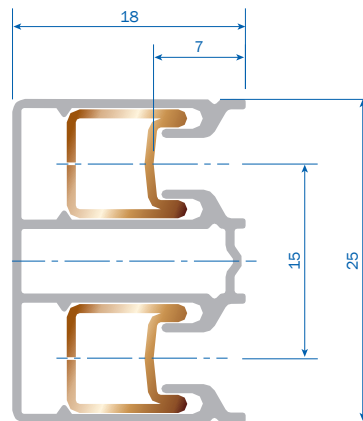

STRAIGHT SECTION, 3-POLE

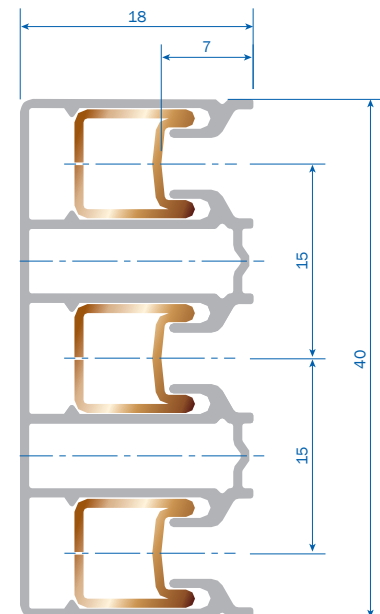

*For applications permanently below 0 °C (cold storage) please inquire separately.

** C= Conductor material copper; F= Conductor material galvanized steel. Feed length for galvanized steel version max. 100 meters

*** At phase spacing of 15 mm and a frequency of 50 Hz

CURRENT COLLECTOR FOR VCL 2 – 3

CURRENT COLLECTOR SET EASL

Max. current: 20 A
 Deflection ± 20 mm
 Stroke ± 15 mm

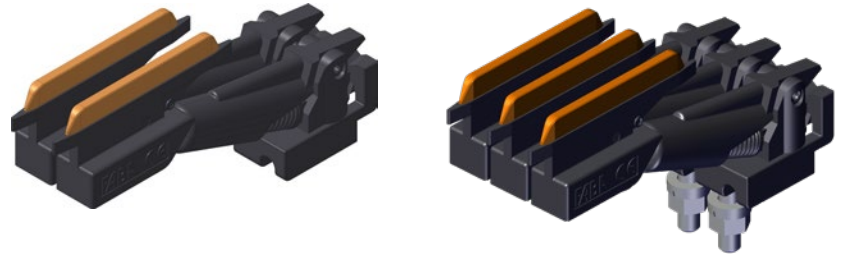

Current collector set D-EAS

Max. current: 30 A
 Deflection ± 20 mm
 Stroke ± 12 mm

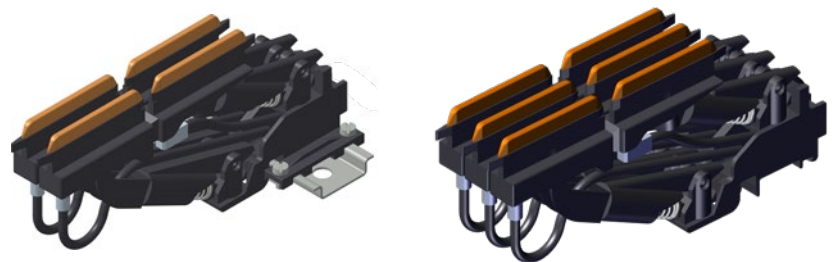

CURRENT COLLECTOR FOR VCL 4 – 6

CURRENT COLLECTOR SA-PASK

Max. current: 50 A
 Deflection: ± 20 mm
 Stroke: ± 15 mm

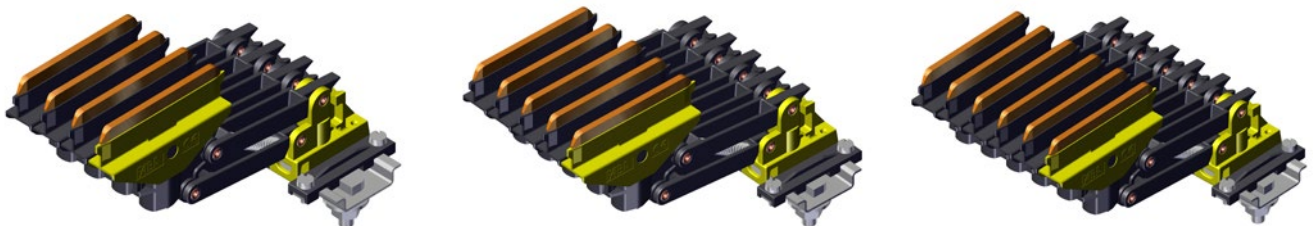



Paul Vahle GmbH & Co. KG

Westicker Str. 52
59174 Kamen
Germany

Tel.: +49 2307 704-0
Fax: +49 2307 704-444
info@vahle.de

www.vahle.com