

ORIGINAL OPERATING INSTRUCTIONS

VKS10
COMPACT CONDUCTOR SYSTEM

SYSTEM MANUAL
INSTALLATION MANUAL
MAINTENANCE MANUAL

EN | V1.03 | DCL 060

TABLE OF CONTENTS

1	Document history	3
2	General	4
2.1	About these instructions	4
2.2	Symbols	4
2.3	Copyright protection	5
2.4	Disclaimer	6
2.5	Customer service	6
2.6	Warranty	7
2.6.1	Warranty terms and conditions	7
3	Safety instructions	8
3.1	Safety	8
3.2	Intended use	8
3.3	General risks	9
3.3.1	Danger from electrical energy	9
3.3.2	Risks from hazardous materials	10
3.4	Responsibilities of the operating company	11
3.5	Personnel requirements	12
3.5.1	Qualifications	12
3.6	Personal protective equipment	13
3.7	Safety devices	14
3.8	Conduct in case of danger or accident	14
3.9	Signage	15
4	Technical data	16
4.1	Type plate	17
5	Layout and function	18
5.1	System overview	18
5.2	Brief system description	18
5.3	Assembly overview	19
5.3.1	Straight sections	19
5.3.2	Curved section	22
5.3.3	Connecting material	22
5.3.4	Fixed hangers/sliding hangers	23
5.3.5	End cap	26
5.3.6	Feed terminal	27
5.3.7	Rail separation	29
5.3.8	Transfer funnel	30
5.3.9	Conductor system sections for funnel	31
5.3.10	Double line guide	32
5.3.11	Transfer guide VU 10	33
5.3.12	Compact current collector KESR 32-55	34
5.3.13	Compact current collector trolley KESR 63S	36
5.3.14	Compact current collector trolley KESL 32-63	38
5.3.15	Compact current collector trolley KESL 63S	40
5.3.16	Single collector assembly KST	42

5.3.17	Single collector assembly KSTU43
5.3.18	Connection cables43
5.3.19	Driver.45
5.3.20	HRL support profile VTP 1045
5.3.21	Attachment of the supporting structure.48
5.3.22	Path measuring systems50
5.3.23	Path encoding51
5.3.24	Mounting bracket51
5.4	Installation plan.52
5.5	Interfaces52
5.5.1	Mechanical interfaces52
5.5.2	Electrical interfaces52
6	Transport and storage53
6.1	Safety instructions for transport and storage53
6.2	Transport inspection53
6.3	Compact conductor system53
6.4	Assemblies and individual parts53
7	Commissioning54
7.1	Safety instructions for commissioning.54
7.2	Operation/decommissioning56
7.2.1	Operation56
7.2.2	Decommissioning56
7.3	Assembly prerequisites56
7.4	Assembly tools57
7.5	Installation.58
7.5.1	Conductor system58
7.5.2	Line feed VLS and VNS66
7.5.3	Current collector70
7.5.4	Special components73
7.5.5	Path measuring systems76
7.5.6	Condition after the installation77
7.5.7	Installation completion77
8	Malfunctions78
8.1	Safety information about malfunctions78
8.2	Procedure in the event of malfunction78
8.3	Troubleshooting table79
9	Maintenance80
9.1	Safety information about repairs.81
9.2	Conductor line82
9.3	Current collector83
9.4	Cleaning85
9.4.1	Moving along the rail86
9.4.2	Mast assembly89
9.4.3	Result of cleaning92
9.4.4	Special cleaning procedures92
9.5	Spare parts93

9.6	Wear parts94
10	Disassembly and disposal96
10.1	Preparation for disassembly96
10.1.1	Disassembly96
10.2	Disposal97
11	Protective measures99
11.1	EU conformity declaration99
11.2	UKCA100
	Index101
12	Other documents102
12.1	Safety Data Sheet RIVOLTA-Cleaner102

1 DOCUMENT HISTORY

Material number	Version	Issue	Description/changes
-	1.01	07/2018	First issue
-	1.02	04/2023	Technical data, KESR32-55, connection cables, information on wear and tear of busbar, adjustment of filter class, editorial revision, UKCA
-	1.03	09/2024	<ul style="list-style-type: none">• Adaptation figure fixed suspension AH-VEPS10-VTP chapter 5.3.4• Adjustment table introduction funnel chapter 5.3.8• Adaptation notes installation VEKS 10 chapter 7.5.1• Adaptation replacement conductor rail chapter 9.2• Adaptation mounting end caps chapter 7.5.1• Adjustment chapter disposal 10.2• Adaptation of corporate design

2 GENERAL

2.1 About these instructions

These operating instructions enable the safe and efficient handling of our VAHLE products. This document is an integral part of the installation and must be kept accessible to operating and maintenance personnel in the immediate vicinity. The basic requirement for safe working is compliance with all specified safety instructions and instructions. This documentation does not give instructions for operating the plant/machine in which our system is integrated. In addition, the local accident prevention regulations and general safety regulations for the use of the system apply. Diagrams are for basic understanding and may deviate from the actual version.

2.2 Symbols

Safety instructions in this manual are identified by symbols. Each safety instruction begins with a signal word that indicates the severity of the hazard. The various types of warnings and safety instructions and their structure are explained below.



DANGER!

The source of the hazard is described here.

This combination of a symbol and a signal word indicates an immediately dangerous situation that will result in death or serious injury unless avoided.

► The actions to prevent the hazard are identified here.



DANGER!

The source of an electrical hazard is described here.

This combination of a symbol and a signal word indicates an immediately dangerous situation related to electricity that will result in death or serious injury unless avoided.

► The actions to prevent the hazard are identified here.



WARNING!

The source of the hazard is described here.

This combination of a symbol and a signal word indicates a potentially dangerous situation that may result in death or serious injury unless avoided.

► The actions to prevent the hazard are identified here.



CAUTION!

The source of the hazard is described here.

This combination of a symbol and a signal word indicates a potentially dangerous situation that may result in light or moderate injury unless avoided.

► The actions to prevent the hazard are identified here.

**NOTICE!**

The source of the hazard is described here.

This combination of a symbol and a signal word indicates a potentially dangerous situation that may result in property or environmental damage unless avoided.

- ▶ The actions to prevent the hazard are identified here.

**NOTICE!**

This indicates a reference to another place in this text or another document.

This combination of a symbol and a signal word indicates a reference to another place in this text or in a different document.

- ▶ The places in the text or references to other documents are identified here.

**TIPS AND RECOMMENDATIONS!**

- ▶ Simple tips and recommendations from our long years of experience are provided here.

2.3 Copyright protection

The contents of this manual are protected by copyright. Their use is permitted within the scope of the use of the installation. No further use is permitted without the written permission of the manufacturer. This manual may not be copied, given to any third party, reproduced in any form or by any means, including, but not limited to, exploitation and/or communication of the contents without the written permission of the manufacturer, except for internal purposes.

2.4 Disclaimer

The information in this document has been compiled in consideration of applicable standards and regulations, accepted rules of engineering, as well as our years of knowledge and experience.

The manufacturer shall not be liable for damages resulting from:

- Failure to observe the technical documentation
- Uses other than the intended use
- Use by personnel without the required training
- Unauthorized modifications or technical changes
- Use of non-approved spare parts or accessories

The actual scope of delivery may vary from the descriptions and images in this document in case of custom versions, the selection of additional order options, or due to latest technical changes.

The obligations agreed in the supply contract, the general terms and conditions and the terms and conditions of delivery, and the laws and regulations applicable at the time the contract was signed all apply.

We reserve the right to make technical changes to improve the usability and for further development.

2.5 Customer service

Paul Vahle GmbH & Co. KG
Westicker Str. 52
Tel: +49 (0) 2307 704-0
Fax: +49(0) 2307 704-4 44
59174 Kamen, GERMANY
Email: info@vahle.de
Web: http://www.vahle.de
Country of origin: Germany

2.6 Warranty

2.6.1 Warranty terms and conditions

The information in this document has been compiled in consideration of applicable standards and regulations, accepted rules of engineering, as well as our accumulated years of knowledge and experience.

The warranty period and the scope of the warranty are defined in the terms of the contract and the general terms and conditions of delivery of Vahle GmbH & Co. KG.

Our general terms of warranty and delivery are published on our website. www.vahle.de



WARNING!

No liability in case of unauthorized changes, modifications, or accessories!

Changes or modifications to the delivered product require the permission of the manufacturer. Genuine spare parts and manufacturer-approved accessories provide safety. The use of non-approved parts voids any liability of the manufacturer.

► Always consult the manufacturer first!

The warranty immediately expires if one or several of the following situations arise(s):

- If the product is modified without permission from Vahle.
- If the operator independently performs repairs during the warranty period or has repairs performed by third parties.
- If the product has been handled or maintained inappropriately.
- If parts are used that are not original parts approved by Vahle.
- If the information in this documentation is not observed.

3 SAFETY INSTRUCTIONS

3.1 Safety

This section gives an overview of all important safety aspects relating to the protection of personnel as well as the safe use and fault-free operation. Other, task-specific safety instructions can be found in the sections on the individual phases of the product's life.



DANGER!

Failure to observe the safety instructions may result in risks to life and health!

3.2 Intended use

Compact conductor systems (type VKS10) are touch-safe conductor rails. The insulating housing (up to 10-pin) enables direct routing in track supports and support profiles. The conductor system must only be used for indoor systems. It can be mounted vertically or horizontally.

Appropriate use includes following all the information in these instructions.

Any use beyond or other than the appropriate use, conversion or other modification is to be considered misuse and prohibited.



WARNING!

Danger in case of improper use!

Improper use may give rise to hazardous situations.

- ▶ Only ever use the system for its intended purpose.
 - ▶ Never let untrained personnel operate the system.
 - ▶ Never modify or alter the system improperly.
 - ▶ Never operate the system in ways that contradict the safety instructions.
 - ▶ Never use the system for outdoors applications.
 - ▶ Never operate the system at higher than specified currents or voltages.
 - ▶ Never operate the system with carbon brushes made by other manufacturers.
 - ▶ Never expose the system to large amounts of water.
-

Claims for damages resulting from improper use shall be invalid.

3.3 General risks

The following section describes residual risks that arise even if the product is used as intended. Observe the safety instructions listed here in the other sections of these instructions to reduce the risk of injuries or damage to property and equipment and to avoid dangerous situations.

Do not change or modify the system inappropriately!



WARNING!

Risk of death from improper replacement or removal!

Errors during the removal or replacement of components may cause life-threatening situations or significant property damage

- ▶ Observe the safety instructions before beginning any removal work.

3.3.1 Danger from electrical energy

Perform the following safety work according to VDE 0105-100 (this work must be carried out by a qualified electrician, see chapter: “2 Security”).

Activate

The required separation distances must be established.

Secure against restart

During work, a prohibition sign must be attached reliably on switching handles or drives of switches, control units, pressure and sensing devices, safety parts, circuit breakers that have been used to unlock a system part or that can be used to connect electricity. If this is not possible, then the clearly associated prohibition sign must be nearby. Existing mechanical interlocking devices against restart must be used for manually operated switches.

Determine absence of voltage

Absence of voltage is to be determined at or as close as possible to the work site at all pins. Absence of voltage must be checked with a voltage tester immediately before and after use.

Grounding and short-circuiting

Parts on which work will be performed at the work place must first be grounded and then short circuited. Grounding and short-circuiting must be visible from the workplace. Deviating from the above, it is permitted to ground and short-circuit near the work place if this is required due to local conditions or for safety reasons. Devices for grounding and short-circuiting must always first be connected with the grounding system or the ground electrode and afterwards with the parts to be grounded. Grounding and short-circuiting may be waived in certain low-voltage systems (see VDE 0100-100).

Cover adjacent, live parts or isolate them

Before starting work, check whether it is appropriate to make adjacent parts voltage-free.



 **DANGER!**

Danger of death due to electrical current!

Contact with live parts can result in life-threatening injuries.

- ▶ Make sure that the relevant components are not live or under voltage, and that there is no unauthorized approximation.
-

3.3.2 Risks from hazardous materials



 **WARNING!**

Danger to health from hazardous materials!

Improper use of hazardous materials may cause damage to health.

- ▶ Observe the manufacturer safety data sheets for hazardous materials used.
-

3.4 Responsibilities of the operating company

Definition of the operating company

The owner is listed in the order confirmation and has the following owner obligations:

Owner obligations

The system is put to commercial use. The owner of the system is therefore subject to laws and regulations on workplace health and safety. In addition to the safety instructions in this document, the safety, accident prevention, and environmental regulations for the system's field of application must be followed. The following applies in particular:

- The owner ensures protection against electric shock (contact protection).
- The owner must inform himself about applicable workplace health and safety regulations and conduct a risk assessment for additional hazards that may arise from the special operating conditions at the installation site. These must be implemented as facility instructions for the operation of the system.
- Over the entire time, the owner has to verify that the instructions drafted by him for the operation of the system conform to the current state of applicable regulations and adapt the instructions as necessary.
- The owner must clearly define responsibilities for the installation, operation, maintenance, and cleaning of the system.
- The owner must ensure that all employees who handle the system have read and understood the operating instructions. The owner is also required to provide training periodically and instruct personnel about the risks.

The owner is also responsible for ensuring that the system is always in good technical condition. The following therefore applies:

- The owner must ensure that the maintenance intervals described in this documentation are observed.
- Control and safety devices provided by the owner for the operation of the system must be checked for completeness and functional safety.
- The owner must ensure that assembly and installation comply with EN 60204.
- The owner must ensure that all components are de-energized in the event of an emergency off. This applies in particular to the parallel busbar.

3.5 Personnel requirements

3.5.1 Qualifications

The tasks described in this manual present various requirements to the qualifications of the persons performing them.



WARNING!

Hazard in case of insufficient qualification of personnel!

Insufficiently qualified persons are unable to judge the risks when working on the system, which puts them and others at risk of severe or fatal injuries.

- ▶ All work must be performed by qualified personnel only.
 - ▶ Insufficiently qualified personnel must stay out of the work area.
-

Operator

The operator has been instructed by the owner about the tasks assigned to him and the risks of inappropriate actions. An operator may perform tasks that go beyond normal operation only if this is indicated in the instructions and the owner has expressly assigned him with such a task.

Electrically qualified person (see VDE 0105-100)

Due to their professional training, knowledge, experience, and knowledge of the relevant standards and regulations, professional electricians are able to carry out work on electrical installations and to independently recognize and avoid possible hazards. The professional electrician has been specifically trained for his/her professional working environment and is conversant with the relevant standards and regulations.

Qualified personnel

Qualified personnel are able, based on their technical training, knowledge, experience, and familiarity with applicable regulations, to perform the assigned tasks and independently detect and avoid potential hazards.

Instructed personnel

The instructed person has been instructed by the owner about the assigned tasks and the risks of inappropriate actions. Such persons must also have read and understood these safety instructions and observe them during their work.

This may need to be confirmed by the customer/user with a signature.

3.6 Personal protective equipment

Every person who is instructed to work on the system or in the vicinity of the system (support personnel) must wear personal protective clothing/equipment for the suitable type of their work. Personal protective equipment has the purpose of protecting personnel against hazards to their health and safety at work. The owner is responsible for ensuring that protective equipment is worn.

Personal protective equipment is described below:



Safety shoes

Safety shoes protect against falling parts as well as against slipping.



Protective goggles

Protective goggles protect against flying particles and liquid sprays.



Helmet

Helmets protect against falling or flying parts and materials.



Gloves

Gloves protect hands against chafing and abrasion, cuts and punctures, as well as against contact with hot surfaces.



Protective work clothes

Work clothing is close fitting and resistant to tearing, with close-fitting sleeves and without any projecting parts. It is designed to protect against being caught by moving parts of machinery. However, it must not reduce mobility. Do not wear rings, necklaces, or other jewelry. Long hair must be covered (cap, hat, hairnet, or similar). Fall-arrest equipment, face protection, and hearing protection according to DGUV Regulation 112-189.



Hearing protection

To protect against severe and permanent hearing loss.



Breathing protection

To protect against severe and chronic conditions of the airways.

3.7 Safety devices



WARNING!

Danger from non-functional safety devices!

Non-functional or disabled safety devices cause a risk of severe injuries or even death.

- ▶ Before beginning any work, verify that all safety devices are functional and installed properly.
- ▶ Never disable or override safety devices.

In addition to locally applicable safety regulations, the following safety instructions must be observed.

The following accident prevention regulations (UVV; Germany) and the new Accident Prevention Regulations – Principles of Prevention (DGUV Regulation 1; Germany) must always be observed.

3.8 Conduct in case of danger or accident

Precautions:

- Have first-aid equipment (first-aid kit, blankets, etc.) and fire extinguisher ready.
- Maintain free access for emergency services vehicles.

Conduct in case of accident:

- Secure site of accident and call first-aid personnel.
- Alert emergency services.
- Provide first aid.

3.9 Signage

The following symbols and instruction signs are located in the work area. They relate to the immediate environment in which they are installed.



DANGER!

Danger of death due to electrical current!

Contact with live parts can result in life-threatening injuries.

- ▶ Make sure that the relevant components are not live or under voltage, and that there is no unauthorized approximation.
-



WARNING!

Danger from illegible signs!

Over time, labels and signs can get dirty or can become unreadable in other ways, which means that the dangers are not identified and that operating instructions cannot be followed.

- ▶ Always keep all safety, warning, and operating instructions in a legible condition.
-



NOTICE!

Follow instructions!

Only use the designated product after this documentation has been completely read and understood.



4 TECHNICAL DATA

Technical specifications - electrical					
Conductor cross section	[mm ²]	16	25	30	35
Resistance	[Ω/1000 m]	1.102	0.723	0.595	0.510
Impedance	[Ω/1000 m]	1.106	0.728	0.602	0.510
Nominal voltage with ground conductor (PE)	[V]	690 (UL 600)			
Number of pins		4 - 10			
Conductor material		Copper			
Protection class		IP21			
Dielectric strength according to DIN 53481	[kV/mm]	> 25			
Volume resistivity according to IEC 60093	[Ω x cm]	> 1 x 10 ¹⁶			
Surface resistance according to IEC 60093	[Ω x cm]	2.1 x 10 ¹³			
Comparative tracking index according to IEC 60093		CTI > 400			

Technical specifications - mechanical	
Direction of travel	Reversing operation
Traveling speed KESR/KESL	[m/min] 450
Traveling speed KST/KSTU	[m/min] 300
Distance pin	[mm] 14
Max. hanger spacing	[m] 1.2
Conductor rail tolerances	[mm] ± 5 in all directions (The supporting structure must be at right angles to the crane/guide rail)

Technical specifications - operating conditions	
Operating temperature	[°C] - 30 to + 55
Max. humidity at ambient temperature 10 °C to 40 °C	[%] 98 (non-condensing)
Max. deviation of operating temperature	[°C] 50
Flammability (Insulating housing)	Flame-retardant, UL 94 HB
Application	Indoor installations



4.1 Type plate

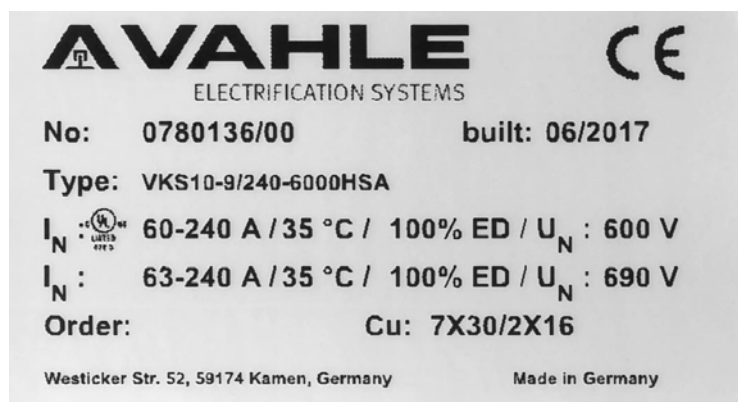

(Example)

The type plate is glued centrally to the back of the conductor rail.



5 LAYOUT AND FUNCTION

5.1 System overview

The VKS10 is an easy-to-install compact conductor system with a maximum load capacity of 280 A. In combination with a support profile developed in parallel, hanging distances of up to 4.5 m can be realized without the need for costly auxiliary support structures. Due to the minimal phase spacing, the contact-protected system requires very little space. Depending on the phase assignment, 3 - 6 poles are available for transmitting control currents in addition to the power supply. In addition, the system allows for cost-effective integration of various position measuring systems. These properties make the VKS system ideally suited for automated high-bay warehouses.

5.2 Brief system description

VAHLE VKS10 conductor systems are contact-protected compact conductor systems. They consist of a flat insulating housing into which the conductor rails are drawn. These conductors are contact-protected. They comply with accident and VDE regulations in the electrical, mechanical and fire engineering sense and are designed according to protection class IP21. The current collectors are protected against contact only if the carbon brushes are fully located in the conductor rails. For conductor rail systems located at arm's length, where under normal operation the current collectors leave the conductor rails, contact protection must be provided on site, e.g. by means of barriers or by switching off. This, however, only applies to ranges above 25 volts AC or 60 volts DC.

The 10-pole insulating housing allows the installation of up to 10 rails in one profile. No special end finishing is required. The compact design enables direct installation in track supports and VAHLE support profiles. The conductor system must only be used for indoor systems. It can be positioned vertically or horizontally. Curved tracks are only possible with horizontal installation.



5.3 Assembly overview

5.3.1 Straight sections

The insulating housings can hold up to 10 conductor rail profiles and provide reliable insulation. Shorter lengths can be supplied. The ground conductor is marked with a continuous yellow stripe. The asymmetrical design reliably prevents phase reversal during installation.

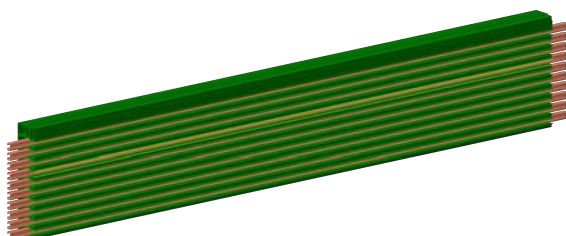

VKS10	
Standard lengths [m]	6
Deep-freeze warehouse [m]	4
Weight [kg]	max. 24
Permissible start/end protrusion at the hanger [mm]	max. 300
Material	Plastic
Conductor rail profile	E-Cu
Conductor rail protrusion 34 mm at 20° C UT	

Connecting material, see 5.3.3

For the following table the types must be added:

e.g. VKS10-6/63-**2000**HSA for 2 m ID no. 780 042. HS = with PE

The 4-digit number (in bold) in the type designation indicates the length of the straight section in mm.

The last digit of the ID no. • indicates the individual length in meters. Please add 1, 2, 3, 4, 5 or 6 to the ID no.

Type	Weight [kg/m]	Nominal current ⁽⁵⁾ [A]	Nominal current ⁽⁴⁾ [V]	Conductor cross section			Number of poles	ID no.
				L1-L3	PE	5-10 ⁽³⁾		
VKS10-4/63-....HSA	2.020	63	690	3x16	1x16	-	4	780 99•
VKS10-4/100-....HSA	2.250	100	690	3x25	1x16	-	4	780 71•
VKS10-4/120-....HSA	2.359	120	690	3x30	1x16	-	4	780 90•
VKS10-4/140-....HSA	2.520	140 ⁽¹⁾	690	3x35	1x16	-	4	780 68•
VKS10-5/63-....HSA	2.156	63	690	3x16	1x16	1x16	5	780 61•
VKS10-5/100-....HSA	2.384	100	690	3x25	1x16	1x16	5	780 70•
VKS10-5/120-....HSA	2.729	120	690	3x30	1x16	1x16	5	780 62•
VKS10-5/140-....HSA	2.864	140 ⁽¹⁾	690	3x35	1x16	1x16	5	781 28•
VKS10-6/63-....HSA	2.300	63	690	3x16	1x16	2x16	6	780 04•
VKS10-6/100-....HSA	2.540	100	690	3x25	1x16	2x16	6	780 05•
VKS10-6/120-....HSA	2.640	120	690	3x30	1x16	2x16	6	780 06•
VKS10-6/140-....HSA	2.810	140 ⁽¹⁾	690	3x35	1x16	2x16	6	780 07•
VKS10-7/63-....HSA	2.450	63	690	3x16	1x16	3x16	7	780 03•
VKS10-7/100-....HSA	2.680	100	690	3x25	1x16	3x16	7	780 08•
VKS10-7/120-....HSA	2.810	120	690	3x30	1x16	3x16	7	780 09•



Type	Weight [kg/m]	Nominal current ⁽⁵⁾ [A]	Nominal current ⁽⁴⁾ [V]	Conductor cross section			Number of poles	ID no.
				L1-L3	PE	5-10 ⁽³⁾		
VKS10-7/140-....HSA	2.950	140 ⁽¹⁾	690	3x35	1x16	3x16	7	780 01•
VKS10-8/63-....HSA	2.590	63	690	3x16	1x16	4x16	8	780 21•
VKS10-8/100-....HSA	2.830	100	690	3x25	1x16	4x16	8	780 22•
VKS10-8/120-....HSA	2.960	120	690	3x30	1x16	4x16	8	780 23•
VKS10-8/140-....HSA	3.090	140 ⁽¹⁾	690	3x35	1x16	4x16	8	780 24•
VKS10-9/63-....HSA	2.740	63	690	3x16	1x16	5x16	9	780 25•
VKS10-9/100-....HSA	2.970	100	690	3x25	1x16	5x16	9	780 26•
VKS10-9/120-....HSA	3.110	120	690	3x30	1x16	5x16	9	780 27•
VKS10-9/140-....HSA	3.240	140 ⁽¹⁾	690	3x35	1x16	5x16	9	780 28•
VKS10-9/200-....HSA	3.280	200 ⁽²⁾	690	6x25	1x25	2x16	9	780 14•
VKS10-9/240-....HSA	3.600	240 ⁽²⁾	690	6x30	1x30	2x16	9	780 13•
VKS10-9/280-....HSA	3.910	240 ⁽¹⁾⁽²⁾	690	6x35	1x35	2x16	9	780 12•
VKS10-10/63-....HSA	2.880	63	690	3x16	1x16	6x16	10	780 29•
VKS10-10/100-....HSA	3.110	100	690	3x25	1x16	6x16	10	780 20•
VKS10-10/120-....HSA	3.250	120	690	3x30	1x16	6x16	10	780 30•
VKS10-10/140-....HSA	3.380	140 ⁽¹⁾	690	3x25	1x16	6x16	10	780 31•
VKS10-10/200-....HSA	3.430	200 ⁽²⁾	690	6x25	1x25	3x16	10	780 10•
VKS10-10/240-....HSA	3.740	240 ⁽¹⁾⁽²⁾	690	6x30	1x30	3x16	10	780 11•
VKS10-10/280-....HSA	4.050	280 ⁽¹⁾⁽²⁾	690	6x35	1x35	3x16	10	780 02•

⁽¹⁾ at 80 % duty cycle

⁽²⁾ Conductor rails connected in parallel

⁽³⁾ Please request N version separately

⁽⁴⁾ UL-approved: $U_{UL} = 600 \text{ V}$

⁽⁵⁾ at 100 % duty cycle at 35° C



Pin allocation

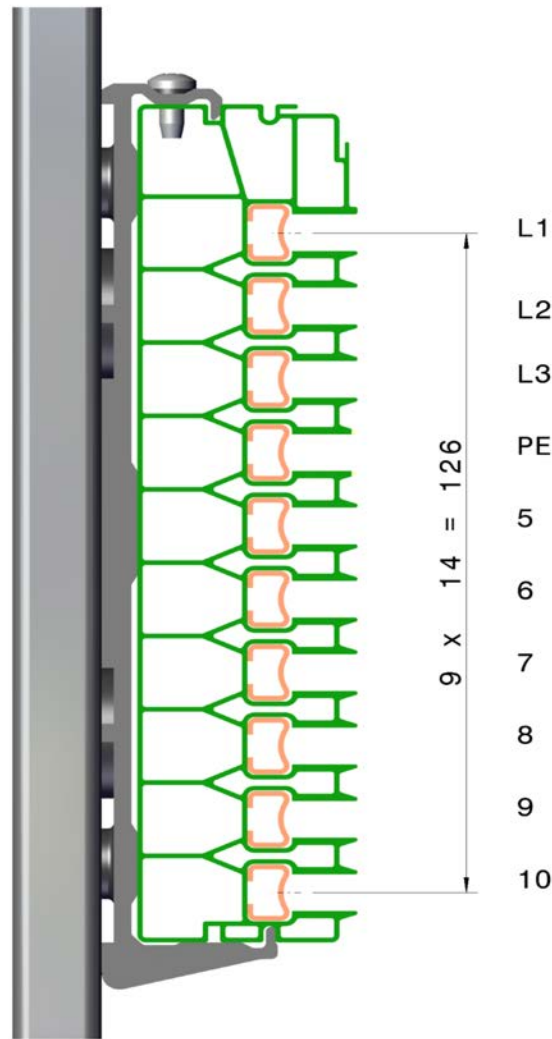

VKS10-4/ 63-140	VKS10-5/ 63-140	VKS10-6/ 63-140	VKS10-7/ 63-140	VKS10-8/ 63-140	VKS10-9/ 63-140	VKS10-9/ 200- 280 ⁽¹⁾	VKS10- 10/63- 140	VKS10- 10/200- 280a
L1	L1	L1	L1	L1	L1	L1	L1	L1
L2	L2	L2	L2	L2	L2	L2	L2	L2
L3	L3	L3	L3	L3	L3	L3	L3	L3
PE	PE	PE	PE	PE	PE	PE	PE	PE
Free	5	5	5	5	5	L1	5	L1
Free	Free	6	6	6	6	L2	6	L2
Free	Free	Free	7	7	7	L3	7	L3
Free	Free	Free	Free	8	8	8	8	8
Free	Free	Free	Free	Free	9	9	9	9
Free	Free	Free	Free	Free	Free	Free	10	10

⁽¹⁾ Conductor rails connected in parallel.



5.3.2 Curved section

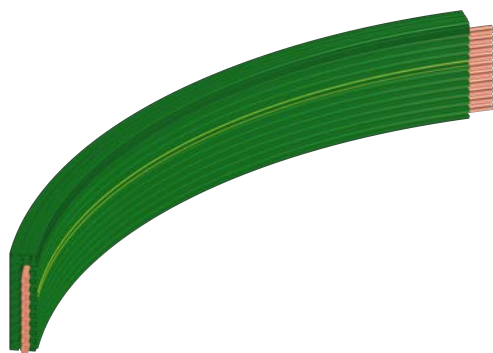

Curved section	
Min. Cu cross section [mm ²]	25
Curve length, max. [m]	5.3
Hanger spacing [m]	≈ 0.6
Angle, max.	180°
Inner curve	Inner conductor
Outer curve	Outer conductor (not pictured)

Curved sections are supplied with straight connection ends of 250 mm length on both sides. Small radii on request.

Type	R [mm]	ID no.
Inner curve, lateral (R > 1000)	≥ 1000	780 344
Outer curve, lateral (R > 1500)	≥ 1500	780 345

5.3.3 Connecting material

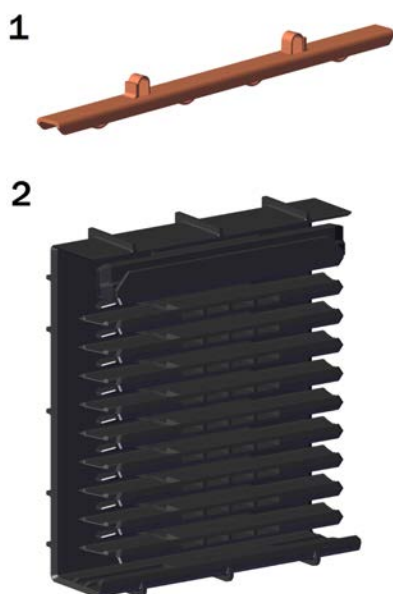

Connecting material	
1	Plug connector for 63-100 A / 120-140 A. Differentiation by marking on connector.
2	Connecting cap (plastic)
Plug connector	E-Cu

The connecting material is used for electrical and mechanical connection. The insulating housings are connected with one-piece connector cover caps, the conductor rail profiles are connected with spring-loaded copper plug connectors.

Where hall expansion joints are present, use expansion joint sections (on request).

Type	Weight [kg]	Number of poles	ID no.
VM-SV10-4/63-100	0.385	4	781 321
VM-SV10-4/120-140	0.385	4	781 323
VM-SV10-5/63-100	0.400	5	781 315
VM-SV10-5/120-140	0.400	5	781 277
VM-SV10-6/63-100	0.415	6	781 150
VM-SV10-6/120-140	0.415	6	781 152
VM-SV10-7/63-100	0.430	7	781 153



Type	Weight [kg]	Number of poles	ID no.
VM-SV10-7/120-140	0.430	7	781 155
VM-SV10-8/63-100	0.445	8	781 156
VM-SV10-8/120-140	0.445	8	781 158
VM-SV10-9/63-100	0.460	9	781 159
VM-SV10-9/120-140	0.460	9	781 161
VM-SV10-9/200 ⁽¹⁾	0.460	9	781 162
VM-SV10-9/240-280 ⁽¹⁾	0.460	9	781 163
VM-SV10-10/63-100	0.475	10	781 164
VM-SV10-10/120-140	0.475	10	781 166
VM-SV10-10/200 ⁽¹⁾	0.475	10	781 167
VM-SV10-10/240-280 ⁽¹⁾	0.475	10	781 168

⁽¹⁾ Conductor rails connected in parallel

5.3.4 Fixed hangers/sliding hangers

All sections must be fastened at least twice, with the maximum hanger spacing of 1.2 m being observed. The hanger brackets designed as sliding hangers allow three different types of fastening:

- 1) Installation in VAHLE support profile (clip fastening system)
- 2) Installation in C rail (screw fastening)
- 3) Installation on support brackets (screw fastening)

NOTICE!

The conductor system can slide in the hangers in case of longitudinal expansion. It is secured in the hanger by an additional screw at fixed points. Here, a maximum distance of 6 m between two fixed points must be maintained.



Fixed hanger

on cast-in channel with hanger, fixed point screw

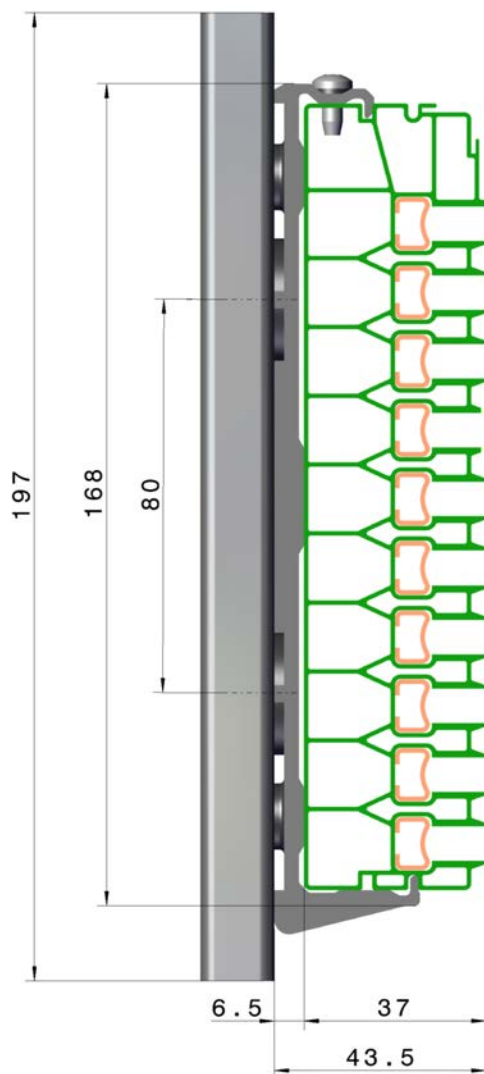
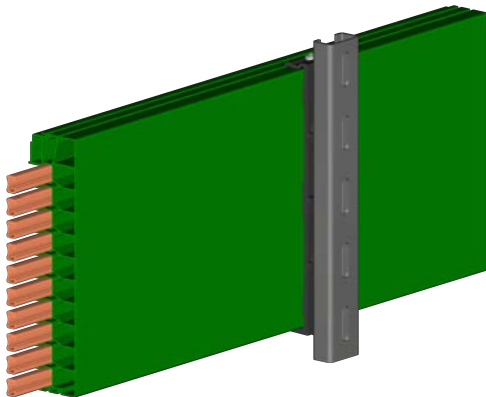

Fixed hanger

Type	AH-VEPS10-H
Weight	[kg] 0.224
ID no.	780 007



Fixed hanger

for VTP10 support profile with hanger, fixed point screw

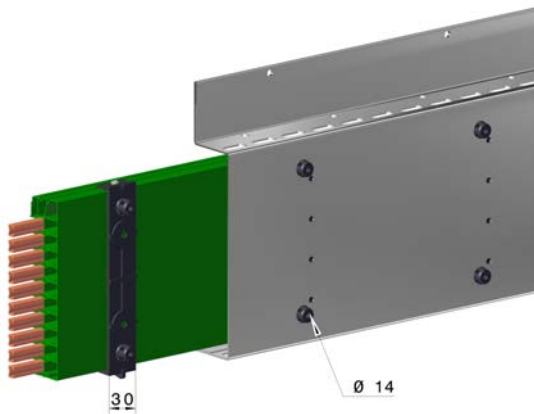

Fixed hanger	
Type	AH-VEPS10-VTP
Weight [kg]	0.033
ID no.	780 009

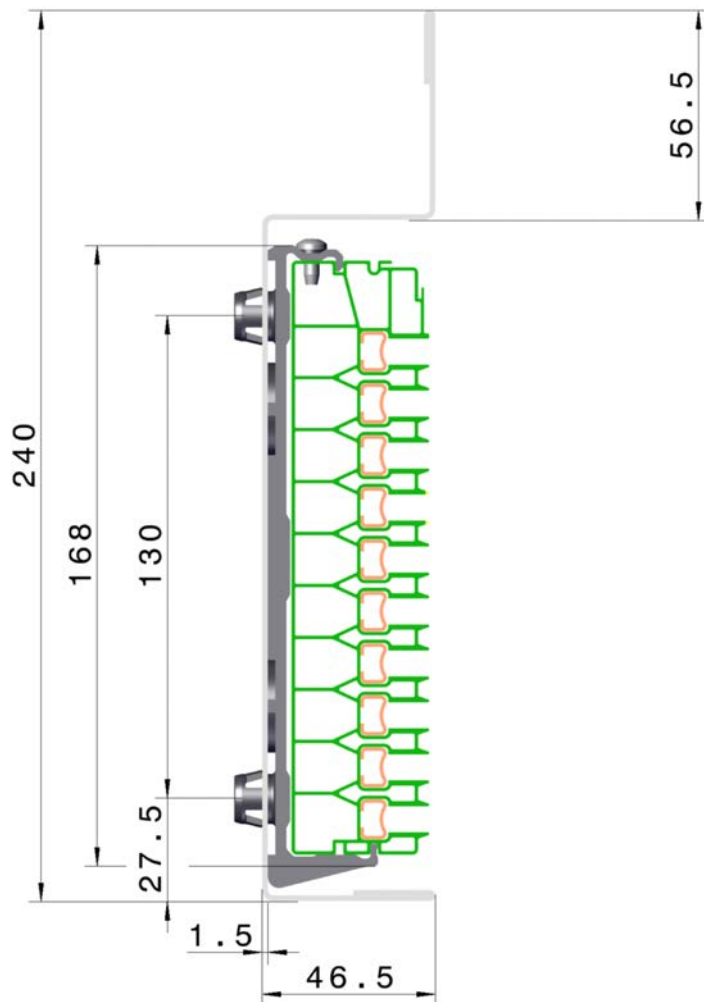



Sliding hanger

on cast-in channel with hanger and bracket profile

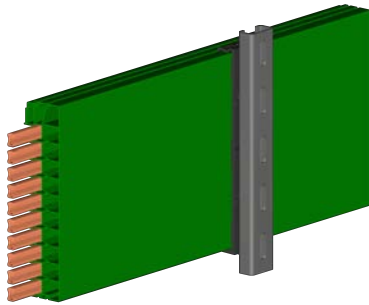

Sliding hanger	
Type	AH-VAS10-H
Weight [kg]	0.223
ID no.	780 008

Sliding hanger

for VTP10 support profile with hanger

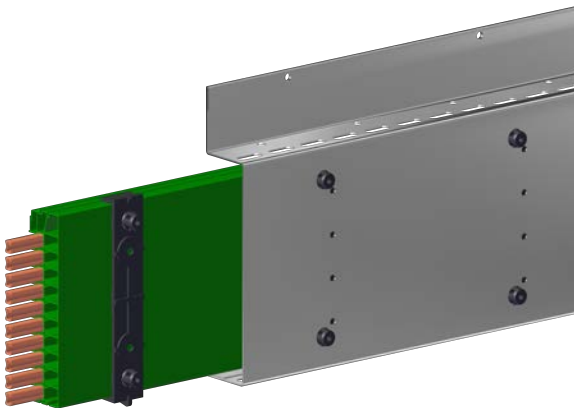

Sliding hanger	
Type	AH-VAS10-VTP
Weight [kg]	0.032
ID no.	780 010

5.3.5 End cap

End caps form the contact-protected end of the conductor system. They are pushed onto the end of the conductor system and screwed into place.

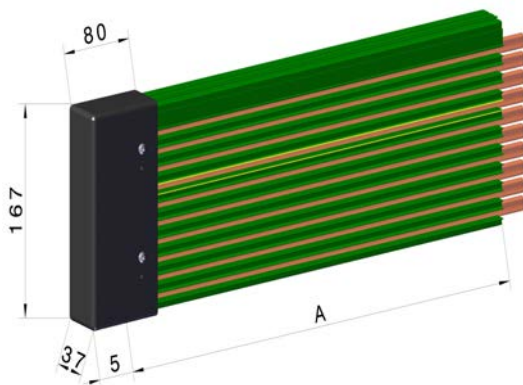

End cap	
Type	EK-VES10L
Weight [kg]	0.210
ID no.	780 004
Material	Plastic
Screw	Galvanized steel
A	Conductor system length
Can be used left or right. Supplied loose as single part with fixing screws.	



5.3.6 Feed terminal

Feed terminals are available as end and line feeds with plastic terminal boxes, or as especially flat line feeds for cable ends to be executed. Both line feed types are supplied mounted on a 1 m straight section. The end feeds are supplied loose and only in connection with the 1 m VLS section.

Component	Material
Connection box	Plastic
Terminal stud	V2A
connecting lug	E-Cu

End feed

Separate delivery of the connection box, only in combination with line feed VLS.

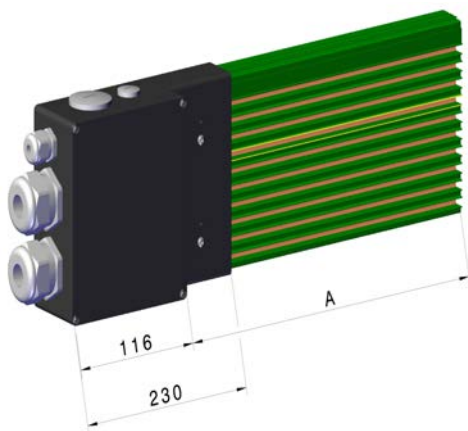

Type	Weight [kg]	ID no.
ES-VEKS10-10/63-280	0.664	780 018

A = conductor system length

Connection box cable glands:

2 x ST-M 40 x 1.5 for $\varnothing = 19-28$ mm

1 x ST-M 20 x 1.5 for $\varnothing = 7-13$ mm

Line feed VLS

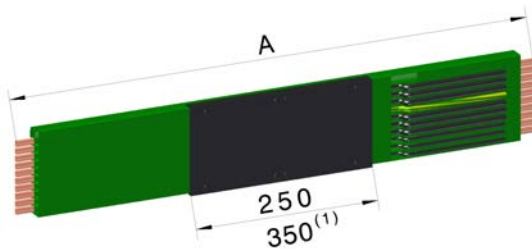

Line feed VLS for connection cables to be executed	
Number of poles	4 - 10
Current [A]	63 - 280
Cable connection M6 with enclosed special cable lugs for single wire	
for 140 A [mm ²]	35 (up to copper conductor \varnothing 8.5 mm)
for 100 A - 120 A [mm ²]	25 (up to copper conductor \varnothing 8.2 mm)
or feed pin for 60 A conductor system	
A = conductor system length 1 m (please order 1m section for this separately)	

Type	Weight [kg]	Current [A]	Number of poles	ID no.
ES-VLS10-4/63	0.217	63	4	781 445
ES-VLS10-4/100-120	0.382	100-200	4	781 479
ES-VLS10-4/140	0.574	140	4	781 478



Type	Weight [kg]	Current [A]	Number of poles	ID no.
ES-VLS10-5/63	0.230	63	5	780 610
ES-VLS10-5/100-120	0.426	100-120	5	780 759
ES-VLS10-5/140	0.630	140	5	780 745
ES-VLS10-6/63	0.217	63	6	780 047
ES-VLS10-6/100-120	0.382	100-120	6	780 060
ES-VLS10-6/140	0.574	140	6	780 187
ES-VLS10-7/63	0.230	63	7	780 049
ES-VLS10-7/100-120	0.426	100-200	7	780 188
ES-VLS10-7/140	0.630	140	7	780 189
ES-VLS10-8/63	0.243	63	8	780 050
ES-VLS10-8/100-120	0.470	100-200	8	780 196
ES-VLS10-8/140	0.686	140	8	780 198
ES-VLS10-9/63	0.256	63	9	780 058
ES-VLS10-9/100-120	0.514	100-200	9	780 199
ES-VLS10-9/140	0.742	140	9	780 191
ES-VLS10-9/200-240(1)	0.744	200-240	9	780 322
ES-VLS10-9/280(1)	0.828	280	9	780 321
ES-VLS10-10/63	0.269	63	10	780 059
ES-VLS10-10/100-120	0.558	100-120	10	780 192
ES-VLS10-10/140	0.798	140	10	780 208
ES-VLS10-10/200-240(1)	0.757	200-240	10	780 318
ES-VLS10-10/280(1)	0.815	280	10	780 317

(1) Larger cover cap

Line feed VNS

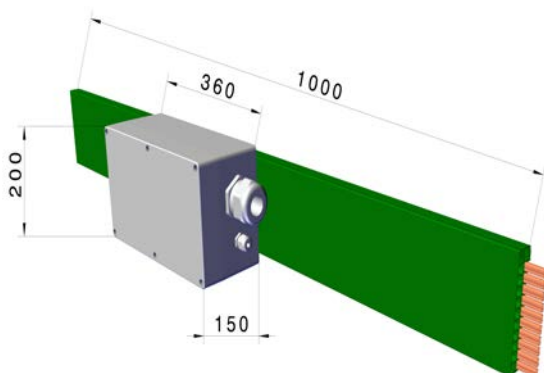

Line feed VNS with connection box	
Number of poles	4 - 10
Current [A]	63 - 280
Cable gland	STR-M 63 x 1.5 for Ø = 28 - 45 STR-M 20 x 1.5 for Ø = 5 - 13
Connecting cable	customer-side
Cable connection	
Main current	M10
Auxiliary current	M5
Cable outlet	left, standard

Please order 1m section for this separately.

Type	Weight [kg]	Current [A]	Number of poles	ID no.
ES-VNS10-10/200-280	2.865	200-280	10	780 332



Type	Weight [kg]	Current [A]	Number of poles	ID no.
ES-VNS10-10/63-140	3.510	63-140	10	780 331
ES-VNS10-9/200-280	2.840	200-280	9	780 334
ES-VNS10-9/63-140	3.324	63-140	9	780 330
ES-VNS10-8/63-140	3.138	63-140	8	780 329
ES-VNS10-7/63-140	2.952	63-140	7	780 328
ES-VNS10-6/63-140	2.766	63-140	6	780 327
ES-VNS10-5/63-140	2.580	63-140	5	780 537
ES-VNS10-4/63-140	2.354	63-140	4	780 527

5.3.7 Rail separation

The rail separation for control pulses electrically separates the conductor system. Installation is carried out at the factory according to customer specifications. The position of the rail separations and the designations of the conductor rail sections to be separated must be specified on ordering.

For designation of the conductor rail profiles, see 5.3.1 Straight sections

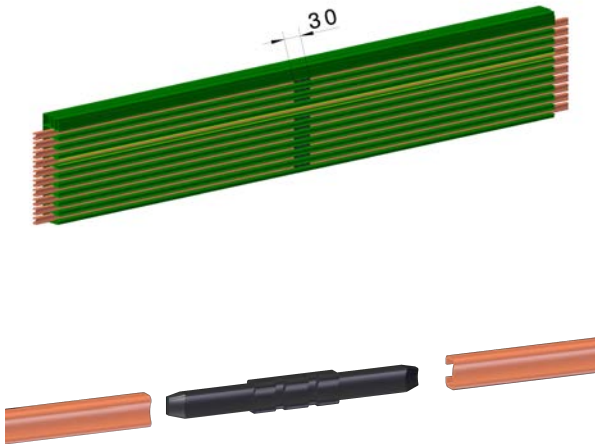

Rail separation	
Weight	[kg] 0.004
Assembly	Pre-assembled delivery
Delivery	Loose delivery on request
currentless section [mm]	30 (longer variant on request)
Material:	Plastic
ID no.	
ST-VSTS1/10-63M	156 933
ST-VSTS1/100M	150 150
ST-VSTS1/120M	151 674
ST-VSTS1/140M	156 335



5.3.8 Transfer funnel

Transfer funnel only in combination with conductor system section. The funnel can be mounted on the left and right of prepared straight sections.

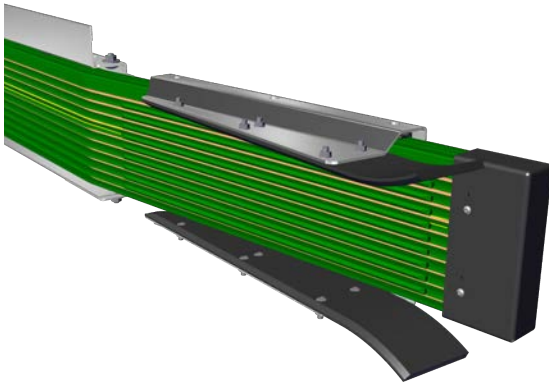

Transfer funnel	
for current collector	KSTU 30-63-14
Speed, max. V [m/min]	100
Funnel strips	Plastic
Funnel holder	Galvanized steel
Attachment material	Galvanized steel
1 Conductor system	see chapter 5.3.1
2 Auxiliary support and clamping brackets	see chapter 5.3.20
3 End cap	see chapter 5.3.5
4 Support profile	see chapter 5.3.1

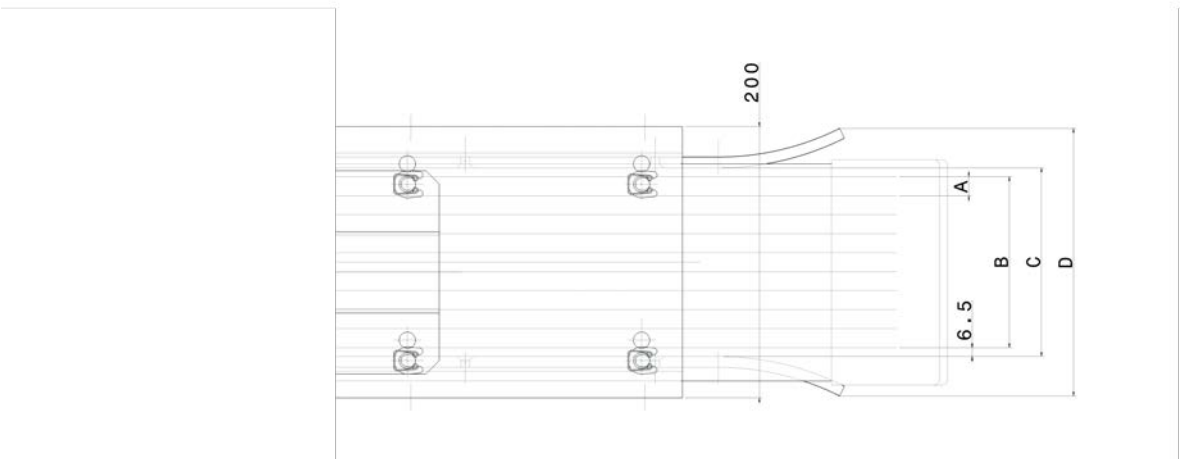
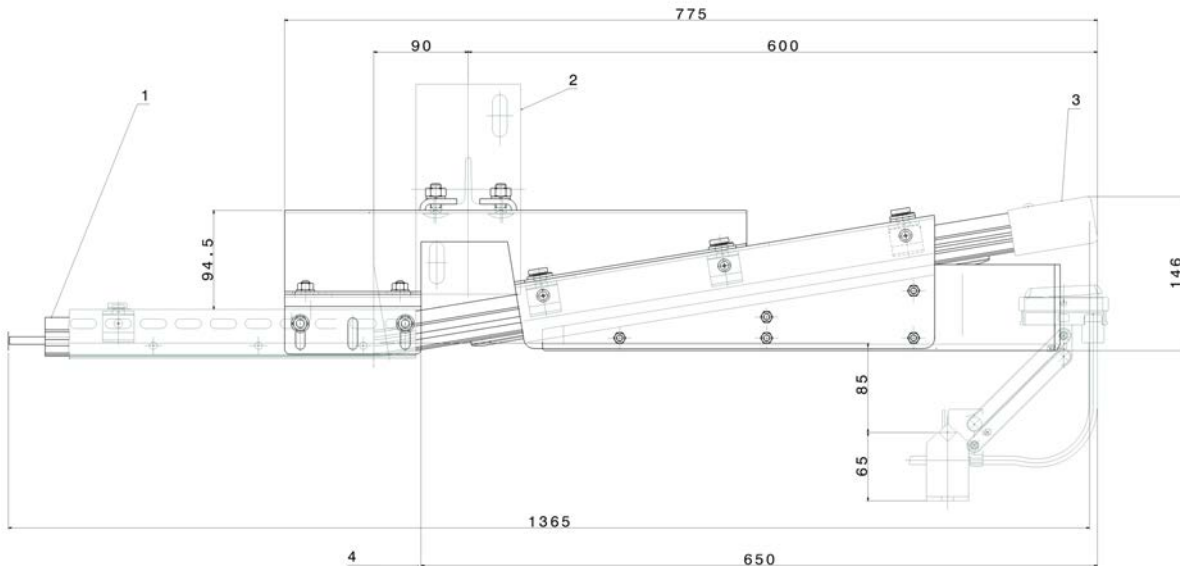



Type	Weight [kg/m]	A [mm]	B [mm]	C [mm]	Number of poles	ID no.
ET-EFTV10-4-KSTU30/63-14L	7.594	42	55	109	4	781 441
ET-EFTV10-4-KSTU30/63-14R	7.594	42	55	109	4	781 440
ET-EFTV10-5-KSTU30/63-14L	7.584	56	69	123	5	780 746
ET-EFTV10-5-KSTU30/63-14R	7.584	56	69	123	5	780 747
ET-EFTV10-6-KSTU30/63-14L	7.574	70	83	137	6	780 350
ET-EFTV10-6-KSTU30/63-14R	7.574	70	83	137	6	780 173
ET-EFTV10-7-KSTU30/63-14L	7.564	84	97	151	7	780 349
ET-EFTV10-7-KSTU30/63-14R	7.564	84	97	151	7	780 172
ET-EFTV10-8-KSTU30/63-14L	7.554	98	111	165	8	780 348
ET-EFTV10-8-KSTU30/63-14R	7.554	98	111	165	8	780 171
ET-EFTV10-9-KSTU30/63-14L	7.554	112	125	179	9	780 347
ET-EFTV10-9-KSTU30/63-14R	7.554	112	125	179	9	780 170
ET-EFTV10-10-KSTU30/63-14L	7.534	126	139	193	10	780 346
ET-EFTV10-10-KSTU30/63-14R	7.535	123	139	193	10	780 169

5.3.9 Conductor system sections for funnel

Type (all cross sections 25 mm ² , length 1365 mm)	ID no.
VKS10-10/100-1365HS02AT	780 257
VKS10-9/100-1365HS02AT	780 250
VKS10-8/100-1365HS02AT	780 249
VKS10-7/100-1365HS02AT	780 248
VKS10-6/100-1365HS02AT	780 247
VKS10-5/100-1365HS02AT	780 743
VKS10-4/100-1365HS02AT	780 169



5.3.10 Double line guide

The double line guide is fastened to a section in the transverse lane. It is aligned together with the current collectors on the storage and retrieval system.

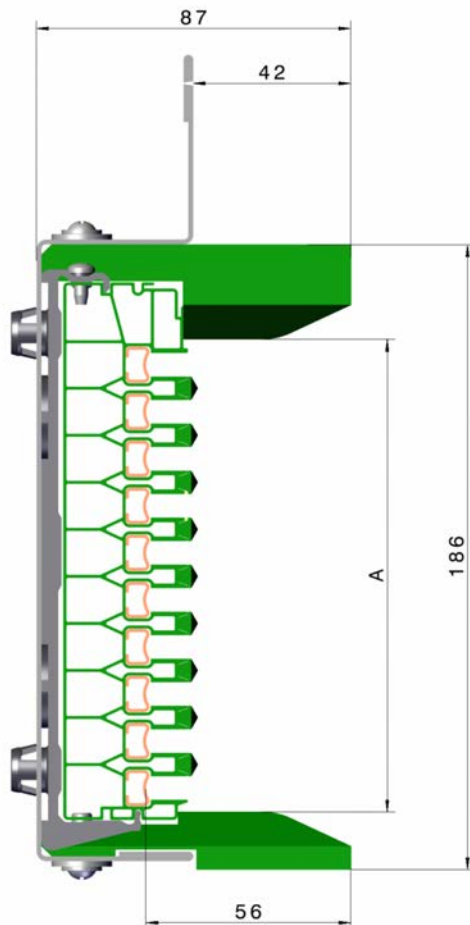
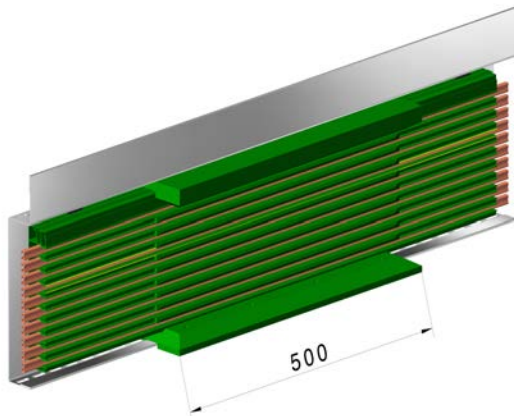

Double line guide	
for current collector	KSTU 30-63
Speed, max. V [m/min]	100
Min. Cu cross section [mm ²]	25
Guide bars	Plastic
Attachment material	Galvanized steel
Tolerances [mm]	x = ± 10 y = + 8 / - 7

Type	Weight [kg]	Dimension A	Number of poles	ID no.
SE-DSEV10-4-KSTU30/63	1.888	56.5	4	781 453
SE-DSEV10-5-KSTU30/63	1.884	70.5	5	781 452
SE-DSEV10-6-KSTU30/63	1.880	84.5	6	780 168
SE-DSEV10-7-KSTU30/63	1.876	98.5	7	780 167
SE-DSEV10-8-KSTU30/63	1.872	112.5	8	780 166



Type	Weight [kg]	Dimension A	Number of poles	ID no.
SE-DSEV10-9-KSTU30/63	1.868	126.5	9	780 165
SE-DSEV10-10-KSTU30/63	1.575	140.5	10	780 164

5.3.11 Transfer guide VU 10

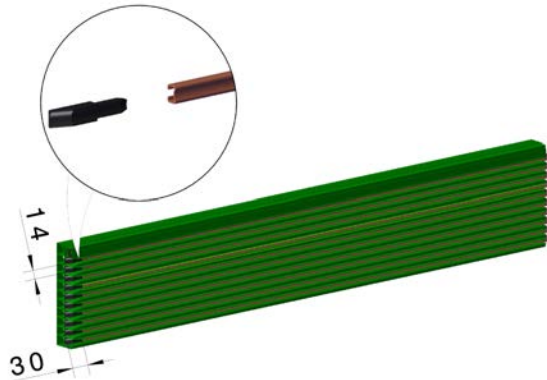

Transfer guide VU 10	
for transitions	
Max. vertical and lateral off-set [mm]	± 2
Max. air gap between the transfer guides [mm]	5
currentless section [mm]	30 (longer variant on request)

Type	Allocation from top	ID no.
US-VU10-4L	Rail 1 - 4	781 456
US-VU10-4R	Rail 1 - 4	781 457
US-VU10-5L	Rail 1 - 5	781 458
US-VU10-5R	Rail 1 - 5	781 459
US-VU10-6L	Rail 1 - 6	780 287
US-VU10-6R	Rail 1 - 6	780 288
US-VU10-7L	Rail 1 - 7	780 227
US-VU10-7R	Rail 1 - 7	780 228
US-VU10-8L	Rail 1 - 8	780 229
US-VU10-8R	Rail 1 - 8	780 230
US-VU10-9L	Rail 1 - 9	780 289
US-VU10-9R	Rail 1 - 9	780 290
US-VU10-10L	Rail 1 - 10	780 269
US-VU10-10R	Rail 1 - 10	780 270



5.3.12 Compact current collector KESR 32-55



KESR 32-55		
Reverse operation and hopper operation		
Installation dimensions	[mm]	88
Phase spacing	[mm]	14
Stroke and lateral deflection	[mm]	± 15
Contact pressure per carbon brush, approx.	[N]	7
Connection cable	Delivery without connection cable	
PE (green) on no. 4 (other configuration possible)		
PE moves forward when folding into the conductor rail		

Connection cables for flat plug connection and screw connection see chapter 5.3.18 Connection cables.

max. current [A]	Flat plug	Screw connection
32	FLA 2,5	AEA 2,5
40	FLA 4,0	AEA 4,0
55	FLA 6,0	AEA 6,0

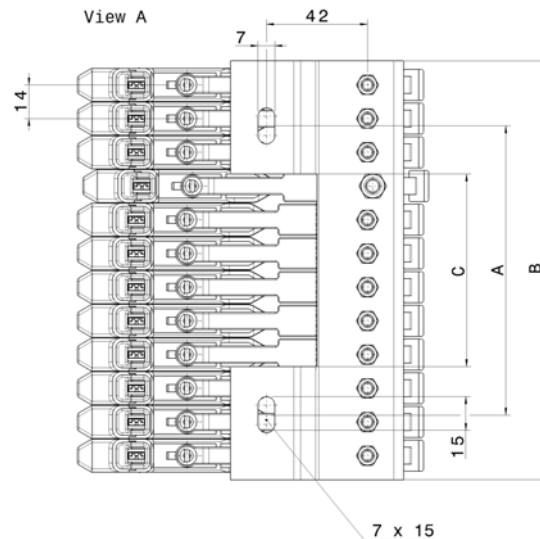
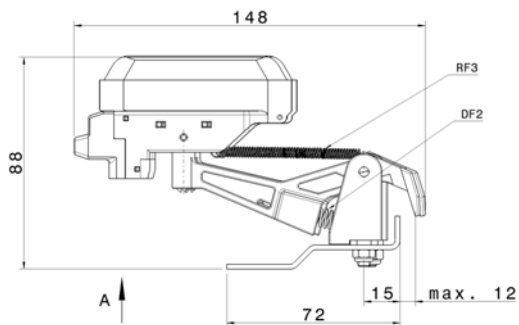



KESR-F

for connecting cable with flat plug.

Type	Weight [kg]	A [mm]	B [mm]	C [mm]	Number of poles	Base plate	ID no.
SA-KESR32-55F-4-14HS-0-04-04	0.480	28	62	-	4	4-pin	143 170
SA-KESR32-55F-5-14HS-0-04-06-06	0.540	56	90	-	5	6-pin (pin 6 free)	143 373
SA-KESR32-55F-6-14HS-0-04-06	0.600	56	90	-	6	6-pin	143 113
SA-KESR32-55F-7-14HS-0-04-08-08	0.660	80	118	53	7	8-pin (pin 8 free)	143 114
SA-KESR32-55F-8-14HS-0-04-08	0.720	80	118	53	8	8-pin	143 115
SA-KESR32-55F-9-14HS-0-04-10-10	0.780	80	146	53	9	10-pin (pin 10 free)	143 116
SA-KESR32-55F-10-14HS-0-04-10	0.840	80	146	53	10	10-pin	143 117

Can be delivered singly	Weight [kg]					Ident-No.	
Type						Phase	PE
SA-KESR32-55F/14...-31-0	0,060					143 111	143 112

KESR-S

Type	Weight [kg]	A [mm]	B [mm]	C [mm]	Number of poles	Base plate	ID no.
SA-KESR32-55S-4-14HS-0-04-04	0.504	28	62	-	4	4-pin	142 937
SA-KESR32-55S-5-14HS-0-04-06-06	0.570	56	90	-	5	6-pin (pin 6 free)	142 938
SA-KESR32-55S-6-14HS-0-04-06	0.636	56	90	-	6	6-pin	142 939
SA-KESR32-55S-7-14HS-0-04-08-08	0.702	80	118	53	7	8-pin (pin 8 free)	142 940
SA-KESR32-55S-8-14HS-0-04-08	0.768	80	118	53	8	8-pin	142 941
SA-KESR32-55S-9-14HS-0-04-10-10	0.834	80	146	53	9	10-pin (pin 10 free)	142 942
SA-KESR32-55S-10-14HS-0-04-10	0.890	80	146	53	10	10-pin	142 943

Can be supplied individually	Weight [kg]					ID no.	ID no.
Type						Phase	PE
SA-KESR32-55F/14...-31-0	0.066					143 120	143 121



5.3.13 Compact current collector trolley KESR 63S

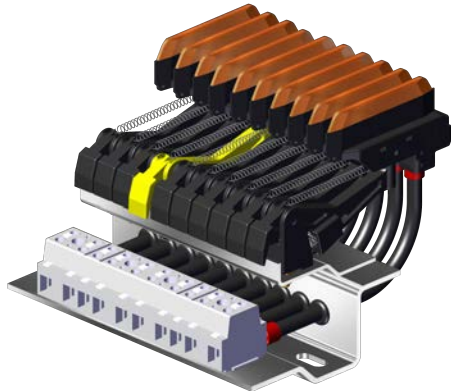

KESR 63S		
Reversing operation		
Adapter plate and terminal block		
Phase spacing	[mm]	14
Stroke and lateral deflection	[mm]	± 15
Contact pressure per carbon brush, approx.	[N]	7
PE (yellow) on no. 4 (other configuration possible)		
PE moves forward when folding into the conductor system		

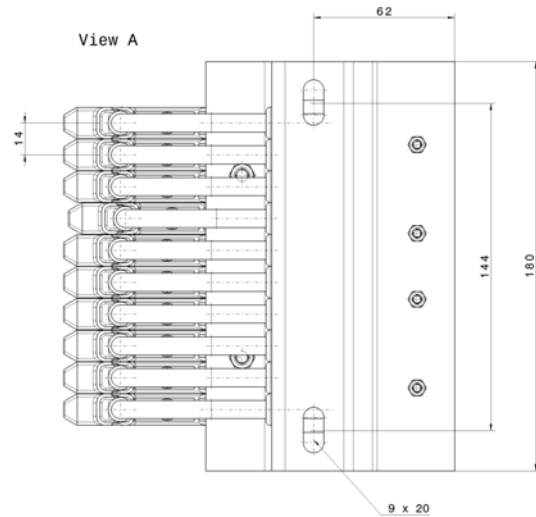
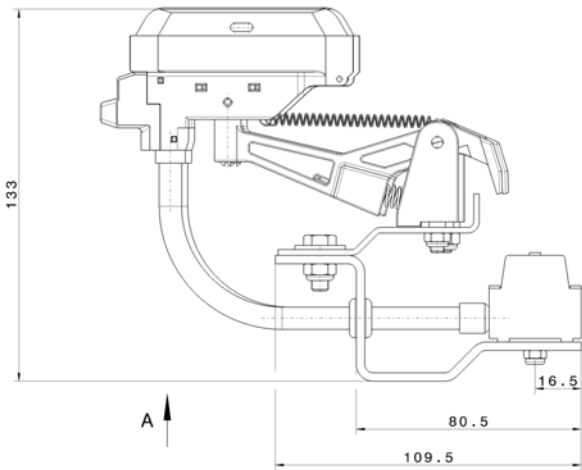



Left version

As illustrated, PE on no. 4

Type	Number of poles	Allocation	ID no.
SA-KESR63S-4-14-HS-KBL-04-10-01-04	4	1 - 4	781 089
SA-KESR63S-5-14-HS-KBL-04-10-01-05	5	1 - 5	781 088
SA-KESR63S-6-14-HS-KBL-04-10-01-06	6	1 - 6	781 087
SA-KESR63S-7-14-HS-KBL-04-10-01-07	7	1 - 7	781 086
SA-KESR63S-8-14-HS-KBL-04-10-01-08	8	1 - 8	781 085
SA-KESR63S-9-14-HS-KBL-04-10-01-09	9	1 - 9	781 084
SA-KESR63S-10-14-HS-KBL-04-10-01-10	10	1 - 10	781 083

Right version

PE on no. 7

Type	Number of poles	Allocation	ID no.
SA-KESR63S-4-14-HS-KBR-07-10-06-10	4	7 - 10	781 096
SA-KESR63S-5-14-HS-KBR-07-10-05-10	5	6 - 10	781 095
SA-KESR63S-6-14-HS-KBR-07-10-05-10	6	5 - 10	781 094
SA-KESR63S-7-14-HS-KBR-07-10-04-10	7	4 - 10	781 093
SA-KESR63S-8-14-HS-KBR-07-10-03-10	8	3 - 10	781 092
SA-KESR63S-9-14-HS-KBR-07-10-02-10	9	2 - 10	781 091
SA-KESR63S-10-14-HS-KBR-07-10-01-10	10	1 - 10	781 090

Spare parts

Type	Description	ID no.
SK-MK63S-31-14	Carbon brush	780 921
SA-KESR32-55S/14PE-31-0	Current collector PE	143 121
SA-KESR32-55S/14PH-31-0	Current collector PH	143 120



5.3.14 Compact current collector trolley KESL 32-63



KESL 32-63		
Reversing operation		
Phase spacing	[mm]	14
Stroke and lateral deflection	[mm]	± 30
Contact pressure per carbon brush, approx.	[N]	7
PE (yellow) on no. 4 (other configuration possible)		
PE moves forward when folding into the conductor system		

max. current [A]	Flat plug	Screw connection
32	FLA 2.5	AEA 2.5
40	FLA 4.0	AEA 4.0
55	FLA 6.0	AEA 6.0
63	-	AEA 10.0

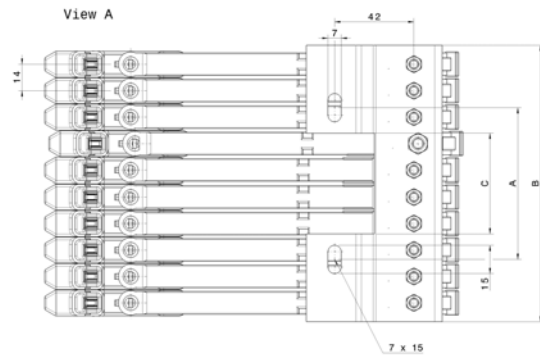
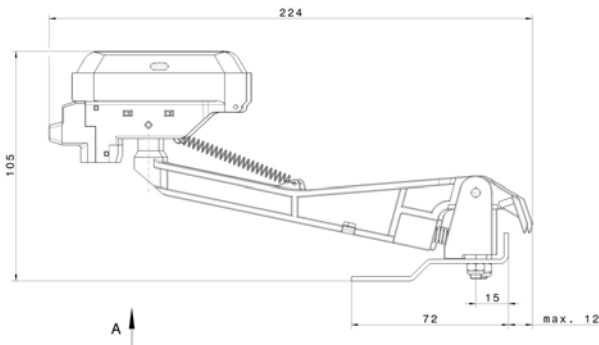

**KESL-F**

for connecting cable with flat plug, see technical catalog.

Type	Weight [kg]	A [mm]	B [mm]	C [mm]	Number of poles	Base plate	ID no.
SA-KESL32-55F-4-14HS-0-04-04	0.536	28	62	-	4	4-pin	143 152
SA-KESL32-55F-5-14HS-0-04-06-06	0.612	56	90	-	5	6-pin (pin 6 free)	781 257
SA-KESL32-55F-6-14HS-0-04-06	0.688	56	90	-	6	6-pin	142 883
SA-KESL32-55F-7-14HS-0-04-08-08	0.764	80	118	53	7	8-pin (pin 8 free)	142 884
SA-KESL32-55F-8-14HS-0-04-08	0.840	80	118	53	8	8-pin	142 885
SA-KESL32-55F-9-14HS-0-04-10-10	0.916	80	146	53	9	10-pin (pin 10 free)	142 886
SA-KESL32-55F-10-14HS-0-04-10	0.992	80	146	53	10	10-pin	142 887

Can be supplied individually	Weight [kg]					ID no.	
Type						Phase	PE
SA-KESL32-55F/14...-31-0	0.076					142 881	142 882

KESL-S

for connecting cable with screw terminal, see technical catalog.

Type	Weight [kg]	A [mm]	B [mm]	C [mm]	Number of poles	Base plate	ID no.
SA-KESL32-63S-4-14HS-0-04-04	0.553	28	62	-	4	4-pin	143 539
SA-KESL32-63S-5-14HS-0-04-06-06	0.637	56	90	-	5	6-pin (pin 6 free)	143 354
SA-KESL32-63S-6-14HS-0-04-06	0.721	56	90	-	6	6-pin	142 888
SA-KESL32-63S-7-14HS-0-04-08-08	0.803	80	118	53	7	8-pin (pin 8 free)	142 889
SA-KESL32-63S-8-14HS-0-04-08	0.885	80	118	53	8	8-pin	142 890
SA-KESL32-63S-9-14HS-0-04-10-10	0.967	80	146	53	9	10-pin (pin 10 free)	142 891
SA-KESL32-63S-10-14HS-0-04-10	1.049	80	146	53	10	10-pin	142 892

Can be supplied individually	Weight [kg]					ID no.	ID no.
Type						Phase	PE
SA-KESL32-63S/14...-31-0	0.084					168 395	142 880



5.3.15 Compact current collector trolley KESL 63S

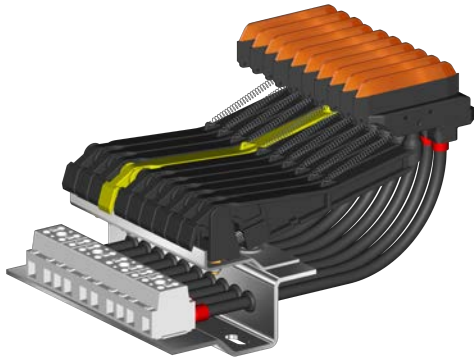

KESL 63S	
Reversing operation	
Adapter plate and terminal block	
Phase spacing [mm]	14
Stroke and lateral deflection [mm]	± 30
Contact pressure per carbon brush, approx. [N]	7
PE (yellow) on no. 4 (other configuration possible)	
PE moves forward when folding into the conductor system	

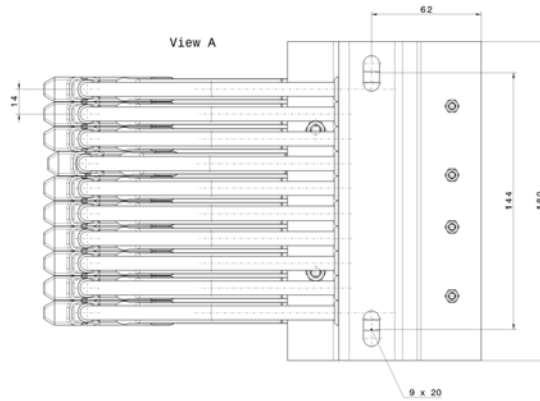
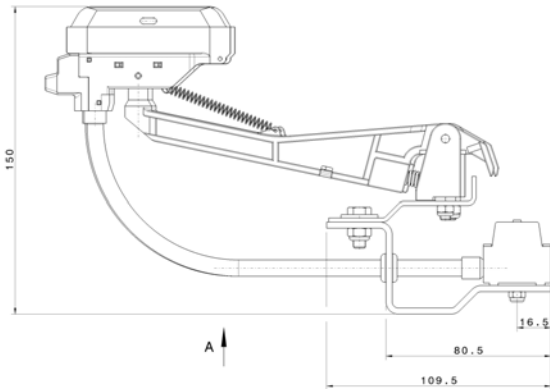



Left version

As illustrated, PE on no. 4

Type	Number of poles	Allocation	ID no.
SA-KESL63S-4-14-HS-KBL-04-10-01-04	4	1 - 4	781 075
SA-KESL63S-5-14-HS-KBL-04-10-01-05	5	1 - 5	781 074
SA-KESL63S-6-14-HS-KBL-04-10-01-06	6	1 - 6	781 073
SA-KESL63S-7-14-HS-KBL-04-10-01-07	7	1 - 7	781 072
SA-KESL63S-8-14-HS-KBL-04-10-01-08	8	1 - 8	781 071
SA-KESL63S-9-14-HS-KBL-04-10-01-09	9	1 - 9	781 070
SA-KESL63S-10-14-HS-KBL-04-10-01-10	10	1 - 10	781 069

Right version

PE on no. 7

Type	Number of poles	Allocation	ID no.
SA-KESL63S-4-14-HS-KBR-07-10-06-10	4	7 - 10	781 082
SA-KESL63S-5-14-HS-KBR-07-10-05-10	5	6 - 10	781 081
SA-KESL63S-6-14-HS-KBR-07-10-05-10	6	5 - 10	781 080
SA-KESL63S-7-14-HS-KBR-07-10-04-10	7	4 - 10	781 079
SA-KESL63S-8-14-HS-KBR-07-10-03-10	8	3 - 10	781 078
SA-KESL63S-9-14-HS-KBR-07-10-02-10	9	2 - 10	781 077
SA-KESL63S-10-14-HS-KBR-07-10-01-10	10	1 - 10	781 076

Spare parts

Type	Description	ID no.
SK-MK63S-31-14	Carbon brush	780 921
SA-KESL32-63S/14PE-31-0	Current collector PE	142 880
SA-KESL32-63S/14PH-31-0	Current collector PH	168 395



5.3.16 Single collector assembly KST

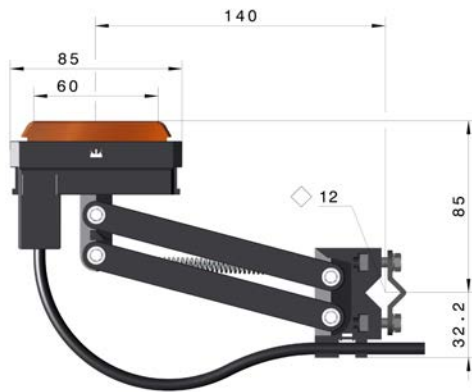

KST	
Reversing operation	
Connecting cable [m]	2
Stroke and lateral deflection [mm]	± 20
Contact pressure, approx. [N]	5

Type	Weight [kg]	Current [A]	Connecting cable		ID no. Phase black	ID no. PE yellow
			A [mm ²]	∅ _{max.} [mm]		
SA-KST30PE-04A-2000	0.240	30	2.50	5	-	152 086
SA-KST30PH-04C-2000	0.240	30	2.50	5	152 085	-
SA-KST55PE-04D-2000	0.368	55	6.00	11	-	154 439
SA-KST55PH-04C-2000	0.368	55	6.00	11	154 438	-
SA-KST63PE-2000	0.394	63	10.00	9	-	156 792
SA-KST63PH-2000	0.394	63	10.00	9	156 791	-



5.3.17 Single collector assembly KSTU

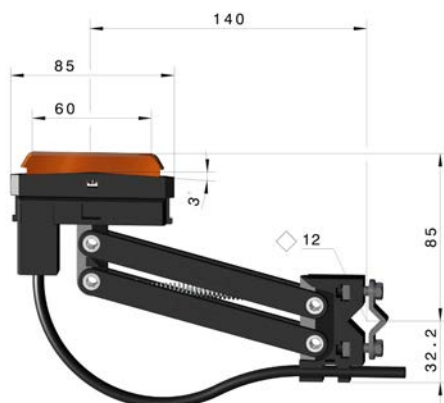

KSTU	
Reversing operation	
for funnel operation and double line guides (multi systems)	
Connecting cable	[m] 2
Stroke and lateral deflection	[mm] ± 20
(± 10 mm to all sides in funnel area)	
Contact pressure, approx.	5
[N]	

Type	Weight [kg]	Current [A]	Connecting cable		ID no. Phase black	ID no. PE yellow
			A [mm ²]	∅ _{max.} [mm]		
SA-KSTU30/14PE-04A-2000	0.240	30	2.50	5	-	168 364
SA-KSTU30/14PH-04A-2000	0.240	30	2.50	5	168 363	-
SA-KSTU55/14PE-04D-2000	0.368	55	6.00	11	-	168 362
SA-KSTU55/14PH-04A-2000	0.368	55	6.00	11	168 361	-
SA-KSTU63/14PE-04D-2000	0.394	63	10.00	9	-	148 019
SA-KSTU63/14PH-04A-2000	0.394	63	10.00	9	148 018	-

5.3.18 Connection cables

Connection cable FLA



FLA	
highly flexible for current collector with flat plug connection "F"	
Observe assignment to current collectors	
Length [m]	1
with female spade connector 6.3 mm x 0.8 mm	
Longer connection cable available	
Temperature range [° C]	-10 to +70

Type	Weight [kg]	A [mm ²]	∅ _{max.} [mm]	ID no. Phase black	ID no. PE yellow
AL-FLA2.5PE1-6.3	0.080	2.50	4.00	-	165 050
AL-FLA2.5PH1-6.3	0.100	2.50	4.00	165 049	-
AL-FLA4PE1-6.3	0.100	4.00	6.00	-	165 052
AL-FLA4PH1-6.3	0.150	4.00	6.00	165 051	-



Type	Weight [kg]	A [mm ²]	∅ _{max.} [mm]	ID no. Phase black	PE yellow
AL-FLA6PE1-6.3	0.150	6.00	7.00	-	166 369
AL-FLA6PH1-6.3	0.080	6.00	7.00	166 369	-

Connection cable AEA



AEA	
highly flexible for current collector with screw connection "S"	
Length [m]	1
Longer connection cable available	
Temperature range [°C]	-10 to +70

Type	Weight [kg]	A [mm ²]	∅ _{max.} [mm]	ID no. Phase black	PE yellow
AL-AEA2.5PE-32-3.7-1000-D	0.038	2.50	3.90	-	143 079
AL-AEA2.5PH-32-4-1000-A	0.038	2.50	3.90	143 080	-
AL-AEA4PE-40-4.4-1000-D	0.063	4.00	5.40	-	143 077
AL-AEA4PH-40-5.6-1000-A	0.063	4.00	5.40	143 078	-
AL-AEA6PE-55-5.5-1000-D	0.085	6.00	5.70	-	143 075
AL-AEA6PH-55-5.9-1000-A	0.085	6.00	5.70	143 076	-
AL-AEA10PE-63-8.2-1000-D	0.160	10.00	8.20	-	143 073
AL-AEA10PH-63-8.4-1000-A	0.160	10.00	8.20	143 074	-



5.3.19 Driver

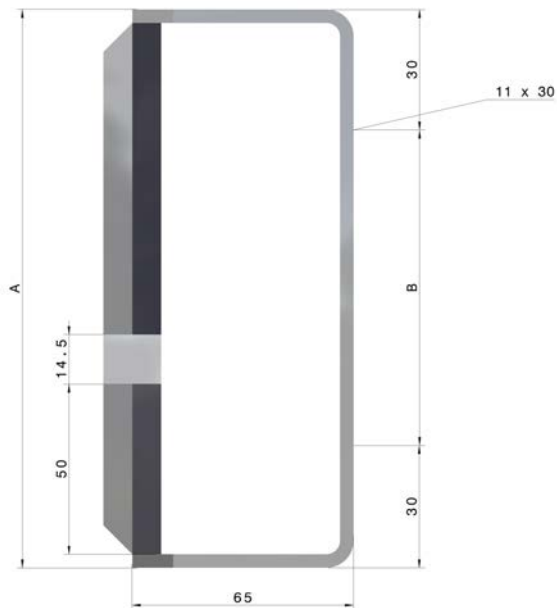

Driver	
For current collector	KST 30-63

Type	Weight [kg]	A [mm]	B [mm]	ID no.
MN-UMAA12HS-B-4-14L-80	0.33	80	20	781 444
MN-UMAA12HS-B-4-14R-80	0.33	80	20	781 443
MN-UMAA12HS-B-5-14L-94	0.36	94	34	780 186
MN-UMAA12HS-B-5-14R-94	0.36	94	34	780 185
MN-UMAA12HS-B-6-14L-108	0.39	108	48	780 184
MN-UMAA12HS-B-6-14R-108	0.39	108	48	780 183
MN-UMAA12HS-B-7-14-122	0.42	122	62	780 181
MN-UMAA12HS-B-8-14L-136	0.46	136	76	780 180
MN-UMAA12HS-B-8-14R-136	0.46	136	76	780 179
MN-UMAA12HS-B-9-14L-150	0.49	150	90	780 178
MN-UMAA12HS-B-9-14R-150	0.49	150	90	780 177
MN-UMAA12HS-B-10-14L-164	0.52	164	104	780 176
MN-UMAA12HS-B-10-14R-164	0.52	164	104	780 175

5.3.20 HRL support profile VTP 10

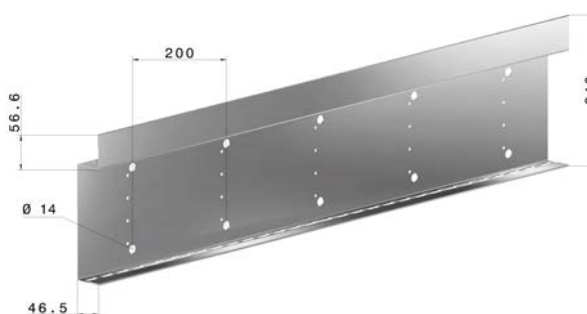

HRL support profile	
Type	VTP10-6000
Length [m]	6
Weight [kg]	4.300
ID no.	780 006



Attachment HRL support profile VTP 10

For feed terminal VNS 10, VLS 10

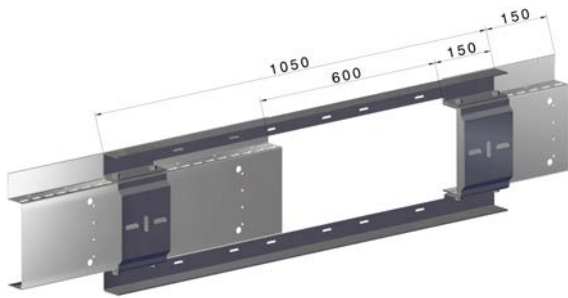

VTPB1050-ESAE

Version	in the start and end area
ID no.	780 100

VTPB1050-ESST

Version	on the line
ID no.	780 098

HRL connector

only as a single part, otherwise included in combination with fastening of the supporting structure. See 5.3.21 Attachment of the supporting structure

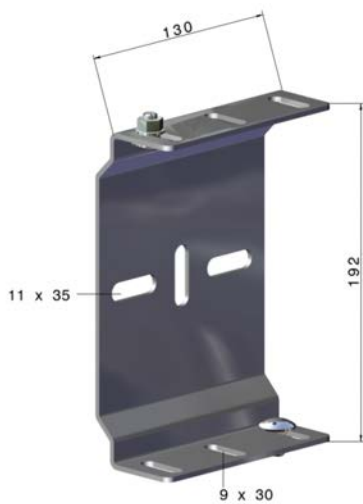

VTPA10-130 HRL hanger

Weight	[kg]	0.878
ID no.		781 007

VTPV10 HRL connector

Weight	[kg]	2.398
ID no.		781 000

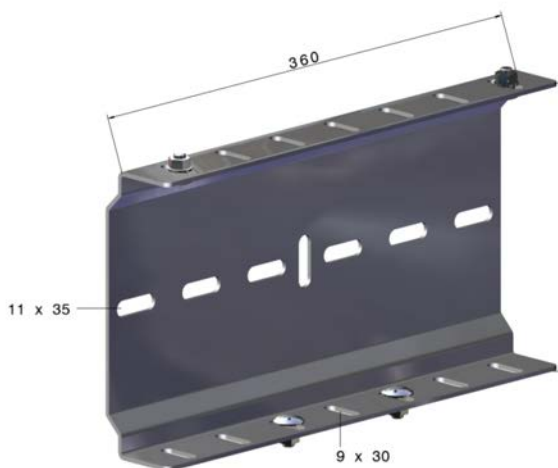



HRL auxiliary support

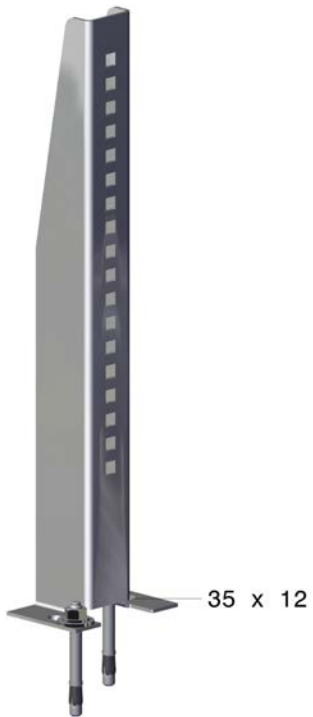

Auxiliary support	
Type	HRL-HSE-500
Length [mm]	500
Weight [kg]	1.894
ID no.	781 677
with attachment material	



5.3.21 Attachment of the supporting structure

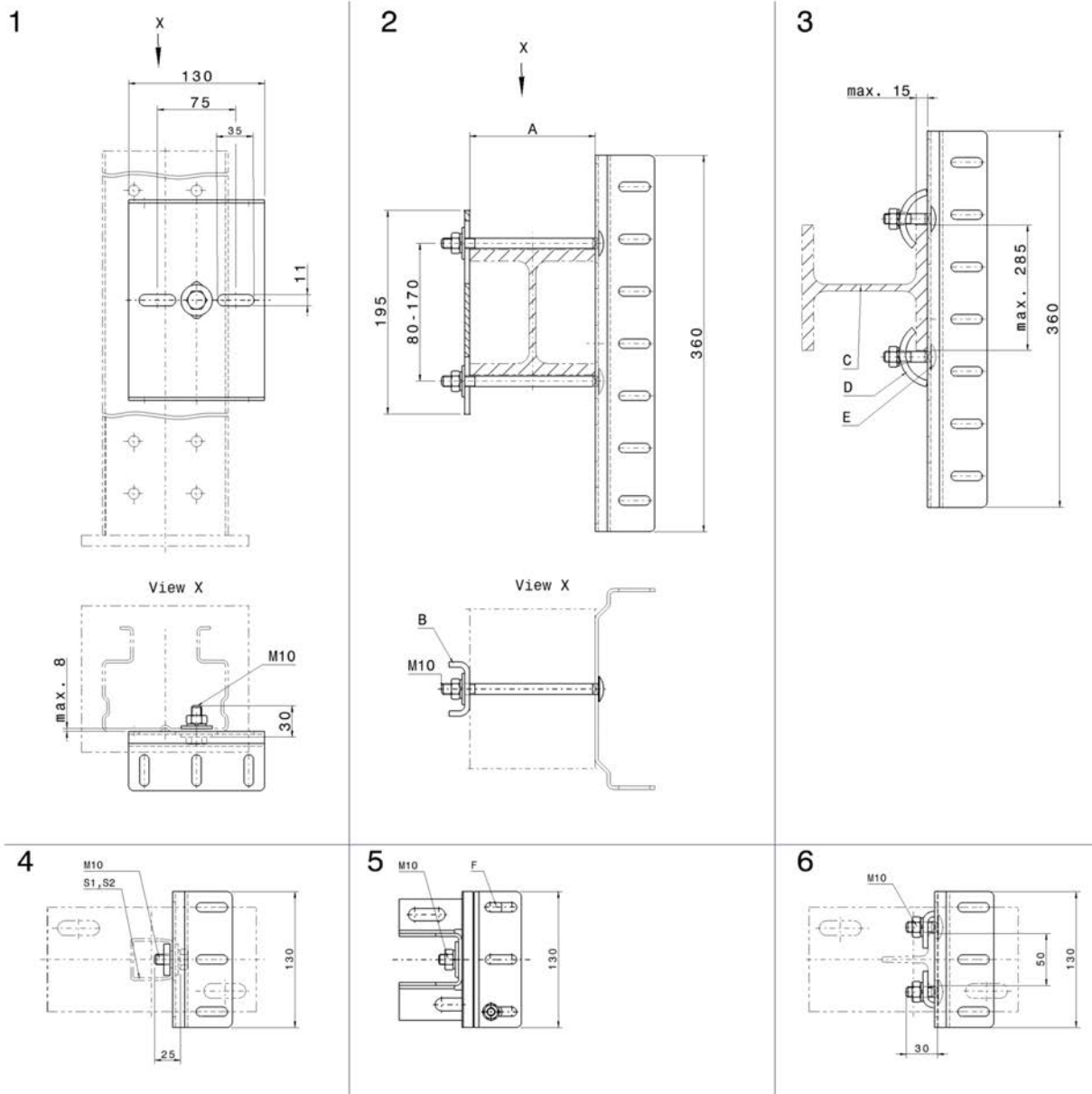

- A clamping area
- B Clamping profile
- C HRL upright
- D Clamping bracket
- E Tightening torque of the mushroom head screw M10, MA = 18 Nm
- F Slot 9 x 30

Type ⁽¹⁾	Weight [kg]	clamping area [mm]	Figure	ID no.
VTPB130-P-30	0.938	max. 8	1	780 147
VTPB360-SPR	2.674	max. 15	3	780 149
VTPB130-SPW	1.066	max. 6	4	780 148
VTPB360-35-45	3.054	35-45	2	780 150
VTPB360-45-55	3.062	45-55	2	780 151



Type ⁽¹⁾	Weight [kg]	clamping area [mm]	Figure	ID no.
VTPB360-55-65	3.076	55-65	2	780 152
VTPB360-65-75	3.084	65-76	2	780 153
VTPB360-75-85	3.096	75-85	2	780 154
VTPB360-85-95	3.102	85-95	2	780 155
VTPB360-90-105	3.110	90-105	2	780 156
VTPB360-100-115	3.118	100-115	2	780 157
VTPB360-110-125	3.131	110-125	2	780 158
VTPB360-120-135	3.144	120-135	2	780 159
VTPB360-130-145	3.152	130-145	2	780 160
VTPB360-140-155	3.164	140-155	2	780 161
VTPB360-150-165	3.712	150-165	2	780 162
VTPB130-S1/2	0.944	max. 8	5	780 163
VTPB130-HST	0.922	max. 8	6	780 678

⁽¹⁾ Larger clamping area on request



5.3.22 Path measuring systems

Cost-effective mounting of various path measuring systems.

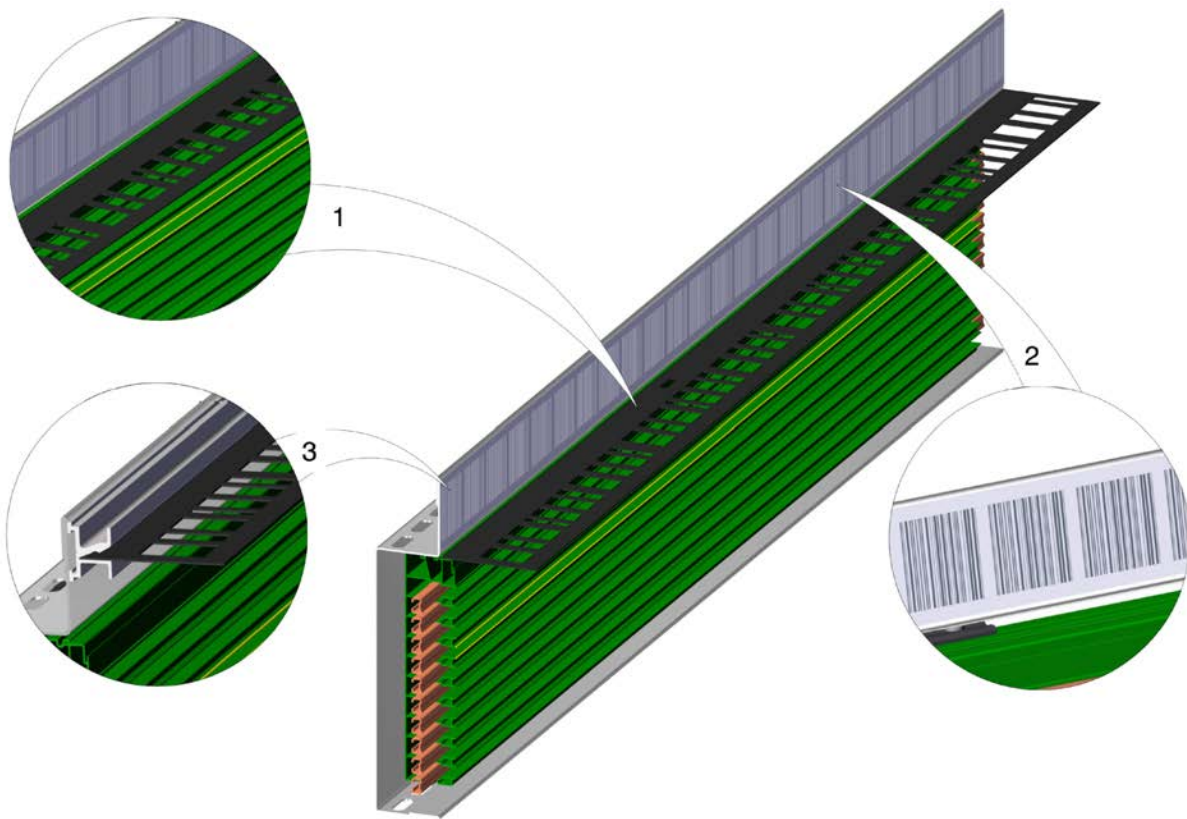

- 1 Path measuring system (WCS 3) Mounted with mounting bracket
- 2 Bar code strip (BCB)
- 3 Path measuring systems (WCS 3) with separate aluminum profile (bore hole provided by customer)

Grounding of the code rail

Grounding	
Type	PS-WCS3-EVTP10
Weight	[kg] 0.026
ID no.	302 160

When installing the WCS code rail in the VKS10 system, the code rail must be connected to the system potential at least every 30 m with low impedance.



5.3.23 Path encoding

Attachment spacing 0.2 m

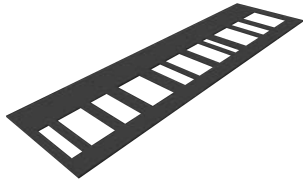

WCS 3	
PS-WCS3-CS70-L2	Plastic laminate tape with special perforation (WCS 3)
Weight [kg]	0.040
max path length [m]	327
ID no.	302 106



Screw	
PS-WCS3-FPK	Screw for fixpoint
Weight [kg]	0.001
ID no.	780 140



BCB	
PS-BCB-50	Bar code strip (BCB)
Weight [kg]	0.015
max path length [m]	10.000
ID no.	302 107

5.3.24 Mounting bracket



Mounting bracket	
Type	PS-WCS3-BKK
Weight [kg]	0.002
Attachment spacing [m]	0.2
ID no.	780 193
for plastic laminate	



5.4 Installation plan

An installation plan is created for each system and enclosed with the documentation. The overview and location of individual components and assembly is also included here. The shorter lengths are given the item number from the order confirmation.

5.5 Interfaces

The conductor systems is supplied complete. The conductive components of the conductor system are contained in an insulating profile.

5.5.1 Mechanical Interfaces

- Customer-side steel structure
- Perfectly aligned, profile upright or (VAHLE) auxiliary support
- On the vehicle side, there is a support bracket for the current collectors which is aligned to the conductor rail system.
- Please refer to the installation plan for the required system dimensions and tolerances.

5.5.2 Electrical Interfaces

- Rubber hose line for VLS infeed
- Customer-side line for VNS infeed
- Tubular cable lug M6 for VLS and M5 + M10 for VNS infeed
- The electrical connection of the feed terminals and current collectors is carried out on site.

6 TRANSPORT AND STORAGE

6.1 Safety instructions for transport and storage



NOTICE!

Damage due to improper transport or storage. Improper transport or storage may cause significant property damage!

- ▶ Storage temperature: 0 °C to +45 °C
- ▶ Storage location: Indoors, dry, no exposure to chemicals.
- ▶ Do not expose to direct sunlight.
- ▶ Exercise caution and observe the symbols on the packaging while unloading the pieces at delivery or during transport on the facilities.

6.2 Transport inspection

Check the delivery for completeness and transport damage upon receipt!

If any external damage is found:

- Refuse delivery or accept delivery only conditionally.
- Note the scope of the damage in the transport documents or on the carrier's delivery note.



NOTICE!

The delivery may be damaged during transport!

Report all defects as soon as they are found. Claims for damages can only be made during the applicable period.

- ▶ Document and report the defects found.

6.3 Compact conductor system

Conductor rail

- Transport and storage in wooden crates.
- Transport by truck



NOTICE!

Incorrect unpacking can lead to damage!

Improper unpacking may lead to property damage and personal injury.

- ▶ Only handle sections using lifting equipment which allows full-surface support or at least a three-point support, for example by using a lifting traverse.

6.4 Assemblies and individual parts

All units and individual parts are packaged in cardboard boxes for transport and storage.



7 COMMISSIONING

7.1 Safety instructions for commissioning



WARNING!

Risk of injury in case of improper operation!

Improper operation may result in serious injury or property damage.

- ▶ Observe the safety instructions from section “3 Safety instructions.”
- ▶ Are all acceptance reports available? (initial startup)
- ▶ Are there no people in the danger zones?
- ▶ Was the assembly performed completely according to instructions?
- ▶ Have excess materials, tools and auxiliary devices been cleared from the danger zones?
- ▶ Has the electrical system been powered up by an authorized electrically trained person (see section “3 Safety instructions”)



WARNING!

Danger to unauthorized persons!

Unauthorized persons who do not meet the requirements described here do not know the dangers in the respective work area.

- ▶ Keep unauthorized persons away from the work area.
- ▶ If in doubt, speak to people and expel them from the work area.
- ▶ Interrupt the work as long as the unauthorized persons are in the work area.



WARNING!

Hazard in case of insufficient qualification of personnel!

Insufficiently qualified persons are unable to judge the risks when working on the system, which puts them and others at risk of severe or fatal injuries.

- ▶ All work must be performed by qualified personnel only.
- ▶ Insufficiently qualified personnel must stay out of the work area.



WARNING!

Risk of injury from falling parts!

In case of improper use (faulty assembly, misuse, failure to perform maintenance, etc.), there is a risk of parts falling down.

- ▶ Wear a helmet
- ▶ Perform regular maintenance

**CAUTION!****Danger of crushing between the individual components!**

During assembly there is a risk of crushing of the extremities between the individual components.

- ▶ Take care of your extremities.
- ▶ Wear personal protective equipment. (see section: 3.6)

**NOTICE!****The conductor rail material is susceptible to corrosion.**

Corrosion can occur when working on the conductor rail with tools.

- ▶ Only tools that have not previously been used for ferritic materials may be used.
- ▶ Use separate tools for the different materials (aluminum, copper, stainless steel).
- ▶ Chip-forming work (grinding etc.) must not be performed in the vicinity of the conductor rail system.

**NOTICE!****The following points have to be strictly observed during assembly!**

- ▶ Appropriate handling of materials.
- ▶ Clean and metallic bright surfaces on all contact points.
- ▶ Smooth crossovers, free of burrs, of the conductor rail profiles at the ends in order to avoid breakdowns and a high carbon brush wear.
- ▶ Firm tightening of all screws using the screw lock provided and observing the stated tightening torques.
- ▶ Exact alignment of the conductor rail to the guide system.
- ▶ Damaged materials must not be installed.
- ▶ Observe all applicable regulations governing installation of the plant.



7.2 Operation/decommissioning

7.2.1 Operation

Operation is understood to be trouble-free, normal operation. Check system as per the maintenance schedule in section: „9 “. If defects occur, stop using the system to prevent damage.

7.2.2 Decommissioning

Switch off the system and secure it against restarting. Disconnect the entire power supply from the system physically.

7.3 Assembly prerequisites

NOTICE!

Ensure that the following requirements are fulfilled before assembling the system:

- ▶ Protective measures have to be taken against unauthorized access and operation during the installation work.
- ▶ The foundation must be designed for the required static and dynamic load.
- ▶ The interfaces as described in 5.5 Interfaces need to be prepared.
- ▶ The installation site must be clean and free of all objects.
- ▶ There has to be adequate lighting over the entire installation site.
- ▶ Tools for proper assembly of the system have to be available (see 7.4 Assembly tools).

Information on installation

Before installation, observe the system-specific installation plan and the applicable system documentation.

- Align the conductor rails and funnels in such a way that the long bar is aligned with the crane runway.
- If specified in the system-specific installation plan, always install curved sections of the conductor system first.
- The hanger spacings are listed in the system-specific installation plan.
- When attaching to the brackets, the sliding hangers may not jam so that the conductor system can move freely.

Observe the following installation distances:

Maximum hanger spacing, VKS	Distance [m]
in straight sections	1.2
in curved sections	0.6
Horizontal	0.6

Maximum hanger spacing, support profile:	Distance [m]
on shelf uprights	4.5
on auxiliary supports	4.0
on walls	3.0
Horizontal	3.0



7.4 Assembly tools

The following devices, tools and measuring equipment are necessary for assembly of the conductor rails with accessories:

- Suitable means of transport for bringing the conductor rails to the installation site (full-area support of the conductor rails).
- adjustable torque wrench for 5 Nm, 7 Nm and 44 Nm
- ½" reversible ratchet with extension and nut, size 17, 13, and 8
- Steel tape measure
- contact angle / 0875
- hack saw
- soft-face hammer, head Ø approx. 50 mm
- Screwdriver set

Mounting fork for connecting cap

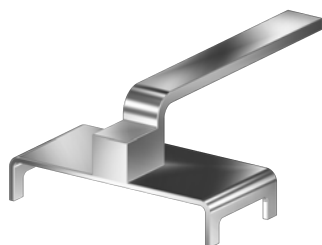

Mounting fork for connecting cap	
Type	MZ-MGVK
Weight [kg]	0.350
Order no.	780 070
Use only with support profile	

Mounting fork for connecting joint

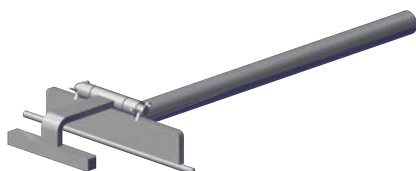

Mounting fork for connecting joint	
Type	MZ-MGVS
Weight [kg]	1.50
Order no.	780 090
Use only with support profile	

Installation comb

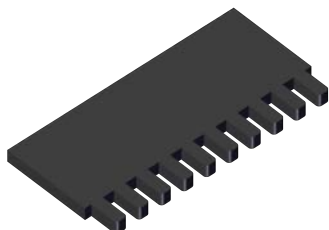

Installation comb	
Type	MZ-MK
Weight [kg]	0.230
Order no.	781 112
Set for VKS10	
For adjusting the air gap at the connecting joint	



7.5 Installation

7.5.1 Conductor system

Prerequisites:

- ✓ Before installation, observe the system-specific installation plan and the applicable system documentation.
- ✓ Align the conductor rails in such a way that the long bar is aligned with the crane runway.
- ✓ If specified in the system-specific installation plan, always install curved sections and track switches of the conductor system first.
- ✓ The hanger spacings for curved sections and track switches are listed in the system-specific installation plan.
- ✓ When attaching to the brackets, the sliding hangers may not jam so that the conductor system can move freely.

Observe the following hanger distances:

Maximum hanger spacing, VKS10	
in straight sections	1.2
in curved sections	0.6
Horizontal	0.6

Maximum hanger spacing, support profile:	
on shelf upright	4.5
on auxiliary supports	4.0
on wall	3.0
Horizontal	3.0

Installing support brackets

The support brackets are required for mounting the VKS hangers. The implementation is carried out by the customer. The use of special structures is possible.

Assembly steps:

1. Mount the support brackets parallel and at right angles to the guide rail.

Installing the HRL support profile

The hanger spacing can be increased with the HRL support profile. The VKS hangers are installed in the support profile.



Assembly steps:

1. The HRL support profile must be mounted parallel and at right angles to the guide rail.
2. Place the first VKS hanger no further than 300 mm from the end of the straight section



Mounting conductor system and adjusting connection joint

Install the conductor system straight and parallel to the crane runway.

The conductor system must be attached to each section with at least two hangers (support bracket or HRL support profile).

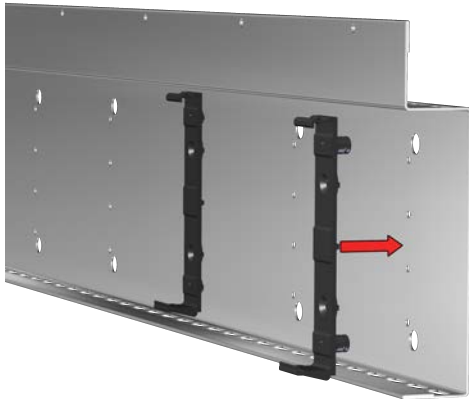

Support bracket

Required tools:

- ✂ Screwdriver for countersunk screw M6

Assembly steps:

1. Attach the hanger to the support brackets by clipping or screwing (M6).

Remove the hanger by unscrewing it with a wrench (SW13).

Step 1 HRL support profile

Assembly steps:

1. Place the hanger in the bore hole provided in the support profile.

NOTICE!

Subsequent assembly applies both to the support brackets and to the HRL support profiles.

- ▶ The WCS laminate code rail mount (1) must always be at the top when arranged sideways.

Step 2

Assembly steps:

1. Insert the conductor system section into the hanger from the front and then snap it into place.

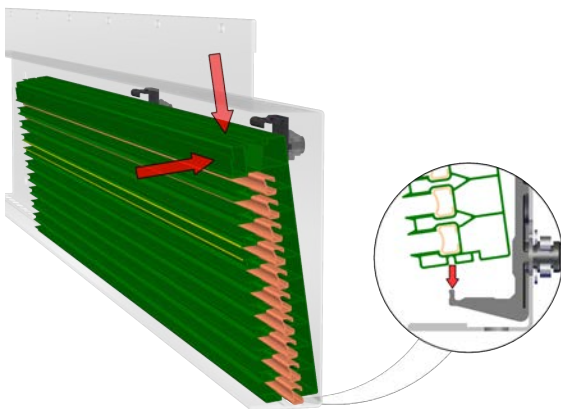

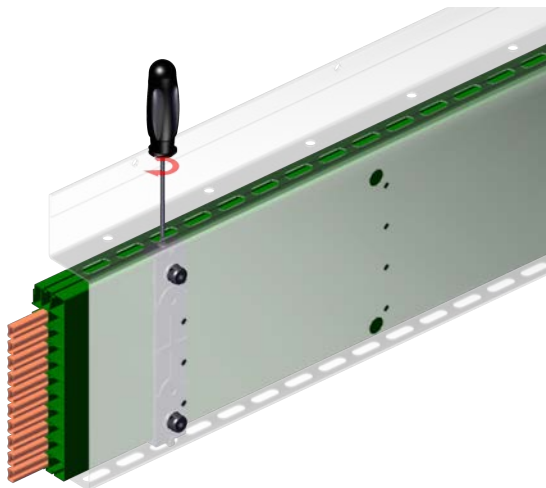

Step 3

Assembly steps:

1. Screw the section to the intended fixed hanger using the screw.

NOTICE!

- ▶ Each section must be equipped with a fixed hanger. The distance between two fixed hangers must not exceed 6 m.

NOTICE!

Range of application - 10° C to + 55° C

6 m lengths for restricted temperature range $\Delta T \leq 50^\circ \text{ C}$:

- ▶ from 10° C to + 40° C delivery length > 4 m
- ▶ from - 30° C to + 20° C delivery length = 4 m

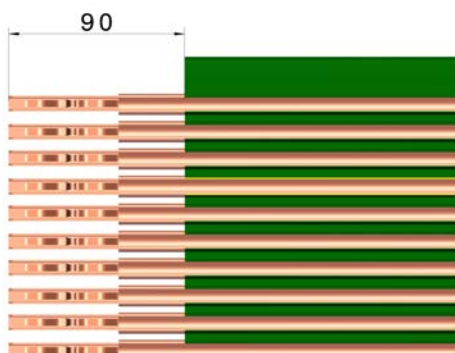

Step 4

Prerequisites:

- ✓ Before inserting, the springs must be checked for proper contact with the connector rail.
- ✓ During insertion, the springs must point towards the curvature of the conductor rail profile.

Required tools:

- ✂ Tape measure

Assembly steps:

1. Slide the connectors into the conductor rail profiles on the section with an even projection of 90 mm.

NOTICE!

Risk of damage to the conductor rail.

- ▶ The connectors are assigned as shown in the diagram on the left and in the table on page 63.

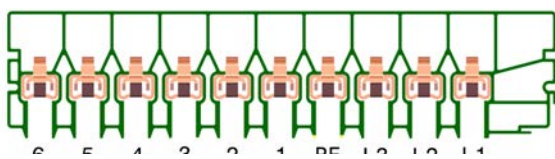

Step 5

Assembly steps:

1. Push the connector cover cap onto one side of the section as far as it will go.

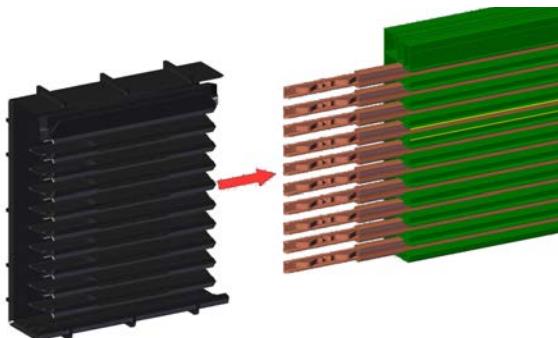

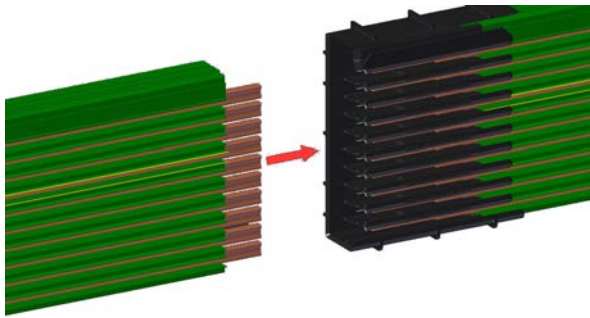

Step 6

Assembly steps:

1. Insert the next section from the front into the hanger and snap it into place.

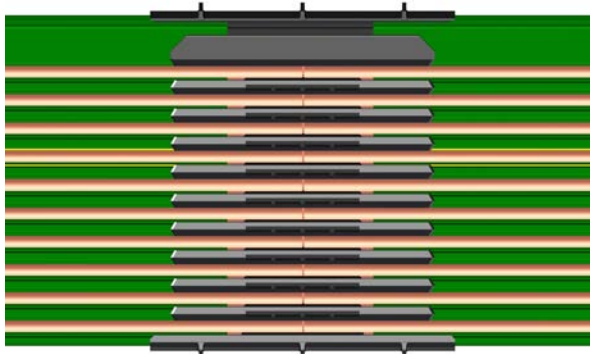

Step 7

Assembly steps:

1. Push the two sections together until the connectors are plugged in. To do this, cover the free end of the conductor system with an impact protection and drive the sections together using a hammer to setting dimension "A" (table page 63).

NOTICE!

- ▶ You can use an installation comb to precisely adjust the air gap in the copper. It is inserted between the copper conductor rails. Depending on the air gap required (0 - 5 mm), the various installation combs can be used (e.g. at an installation temperature of 20° C, the air gap is („A“ = 2 mm).
- ▶ To make assembly easier, an assembly tool can be used for the connecting joint for installation in the HRL support profile.

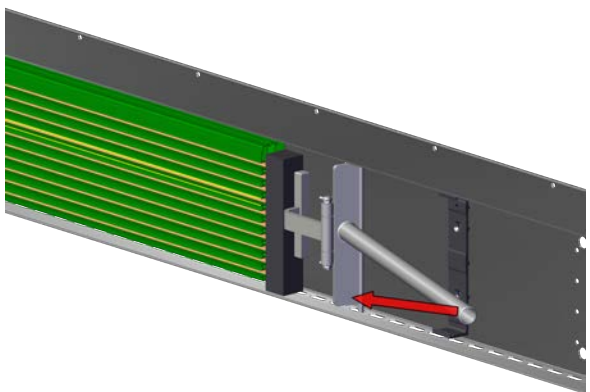

Step 8

Required tools:

- ✂ Plastic block
- ✂ Assembly tool (mounting fork for connecting joint)

Assembly steps:

1. Slide the plastic block over the copper ends. Then insert the assembly tool into the slotted holes of the HRL support profile and slide the section against the other section.

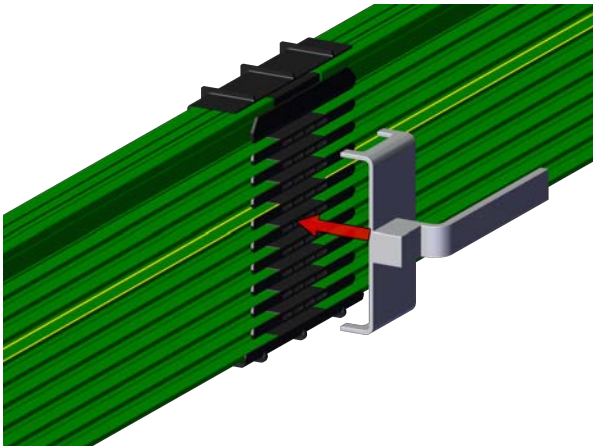

Step 9

Prerequisites:

- ✓ Ensure that the connectors are inserted correctly.

Required tools:

- ✂ Assembly tool (mounting fork for connecting cap)

Assembly steps:

1. Align the connecting cap properly using the assembly tool, which places the cap correctly over the joint.

NOTICE!

- ▶ The setting dimensions according to the table Air gap "A" page 63 only need to be adhered to exactly the maximum temperature range for the respective conductor rail maximum temperature range (- 10° C to + 40° C) is to be expected. For smaller temperature differences (+/- 10° K), the conductor rail can be pushed together to simplify installation, so that a closed copper joint is created. The air gap on the insulating housings adjusts itself automatically.

Step 10

Assembly steps:

1. Install the other sections in the same way.

NOTICE!

- ▶ The distance between the hangers and the connecting caps, feed terminals etc. has to be min. 50 mm to not hinder expansion.



Table of plug connector assignments



Conductor system types	Plug connector (copper)	
	63-100 A	120-140 A
VKS10-4/63-100	L1; L2; L3; PE	-
VKS10-4/120-140	PE	L1; L2; L3
VKS10-5/63-100	L1; L2; L3; PE; 1	-
VKS10-5/120-140	PE; 1	L1; L2; L3
VKS10-6/63-100	L1; L2; L3; PE; 1; 2	-
VKS10-6/120-140	PE; 1; 2	L1; L2; L3
VKS10-7/63-100	L1; L2; L3; PE; 1; 2; 3	-
VKS10-7/120-140	PE; 1; 2; 3	L1; L2; L3
VKS10-8/63-100	L1; L2; L3; PE; 1; 2; 3; 4	-
VKS10-8/120-140	PE; 1; 2; 3; 4	L1; L2; L3
VKS10-9/63-100	L1; L2; L3; PE; 1; 2; 3; 4; 5	-
VKS10-9/120-140	PE; 1; 2; 3; 4; 5	L1; L2; L3
VKS10-9/200	2x L1; 2x L2; 2x L3; PE; 1; 2	-
VKS10-9/240-280	1; 2	2x L1; 2x L2; 2x L3; PE
VKS10-10/63-100	L1; L2; L3; PE; 1; 2; 3; 4; 5; 6	-
VKS10-10/120-140	PE; 1; 2; 3; 4; 5; 6	L1; L2; L3
VKS10-10/200	2x L1; 2x L2; 2x L3; PE; 1; 2; 3	-
VKS10-10/240-280	1; 2; 3	2x L1; 2x L2; 2x L3; PE

Table, air gap "A"

Installation temperature [° C]	-30	-20	-10	0	10	20	30	40
Air gap "A" standard [mm] 6 m sections	-	-	5	4	3	2	1	0
Air gap "A" deep-freeze warehouse [mm] 4 m sections	4.2	3.5	2.8	2.1	1.4	0.7	0	-



Shorter lengths

We manufacture shorter lengths at our factory according to your specifications. If shorter lengths still need to be adapted on site, modify the conductor system as follows.

NOTICE!

- The left side of the conductor rails has been widened at the factory to prevent it from moving inside the plastic housing. Therefore always only shorten the right side. (1) indicates the WCS mount.

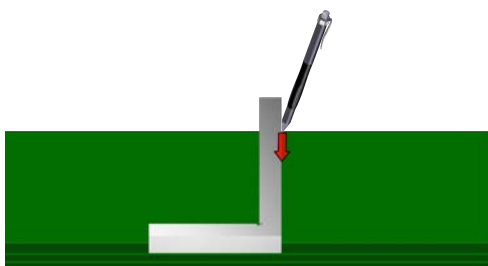

Step 1

Required tools:

- ✂ Contact angle

Assembly steps:

1. Push in the conductor rail on the right side using a wooden board until they are flush with the insulation housing.
2. Mark the new section length at right angles.

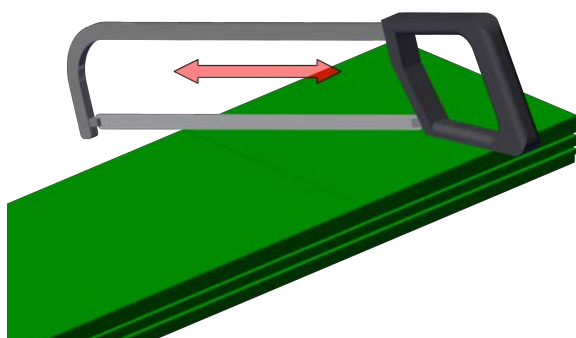

Step 2

Required tools:

- ✂ Hack saw

Assembly steps:

1. Saw off the conductor rail at the marking.



Step 3

Required tools:

- ✂ Tape measure
- ✂ File

Assembly steps:

1. Push the conductor rail back until the same projection "B" of 34?mm is achieved on both sides.
2. Deburr the shortened conductor rail ends and the insulation profile.

Bending the conductor system

The conductor rails are only bent at the factory.

Their minimum radius is:

Inner radius $R = 1000$ mm

Outer curves $R = 1500$ mm.

End caps

End caps form the contact-protected end of the conductor system.

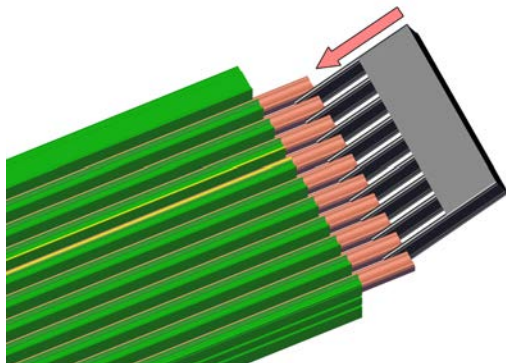

Step 1

Assembly steps:

1. First attach the leakage path extension to the ends.

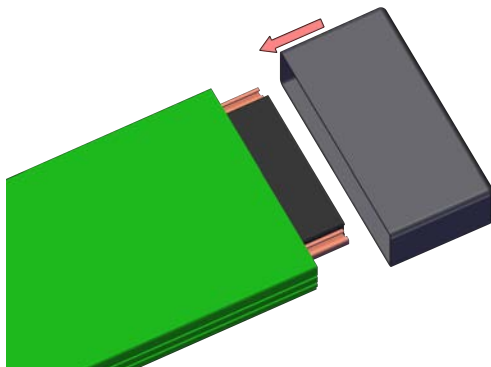

Step 2

Assembly steps:

1. Push the end caps onto the conductor rail ends.

NOTICE!

- The end caps are secured with a screw from the conductor rail side through the existing holes. Observe the markings for right (R) and left (L) on the end cap.

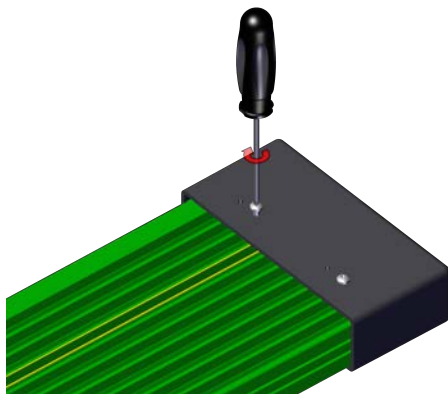

Step 3

Required tools:

- ✂ Screwdriver

Assembly steps:

1. Fit the end caps as shown (hole pattern at the front / on the side of the copper rails)
2. Screw the end caps to the conductor rail housing. The screws are included in the packaging unit.

NOTICE!

- The overhang to the first or last hanger must not exceed 300 mm.

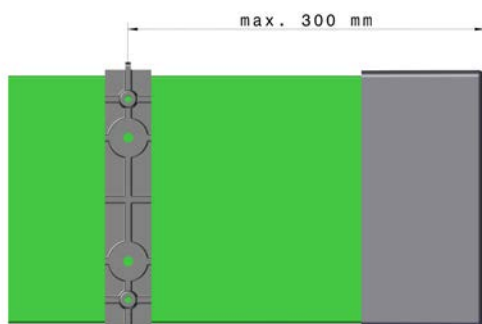



7.5.2 Line feed VLS and VNS

NOTICE!

- ▶ The line feeds are preferably installed on a 1 m conductor system section.

Step 1

Assembly steps:

1. Place the feed terminal as close as possible to the supply line.

To access the feed, the HRL support profile is removed in this area for 600 mm. If the upright, support spacing > is 1.5 m, an additional auxiliary support must be installed (see installation plan).

Line feed VLS

Step 1

Required tools:

- ✂ Screwdriver

Assembly steps:

1. Remove the cover caps from the installed line feed.
2. Remove the outer insulation of the connecting cable in the area of the feed.
3. Strip and cut the connecting cable as required. The additional conductor protection is still given due to the hollow chamber profile.

Step 2

Required tools:

- ✂ Wrench
- ✂ Torque wrench

Assembly steps:

1. Attach the cable lugs to the single wires.
2. Place the terminal studs and spacers in the holes provided for them in the conductor rail.
3. Screw the cable lugs to the terminal studs with the hexagon screws (M6), spring washers and hexagon nuts.

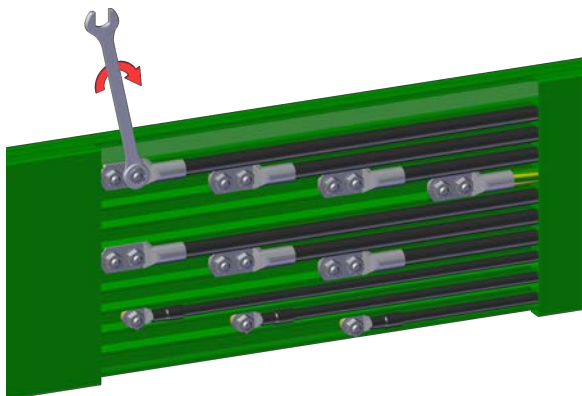

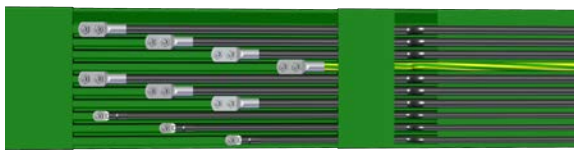
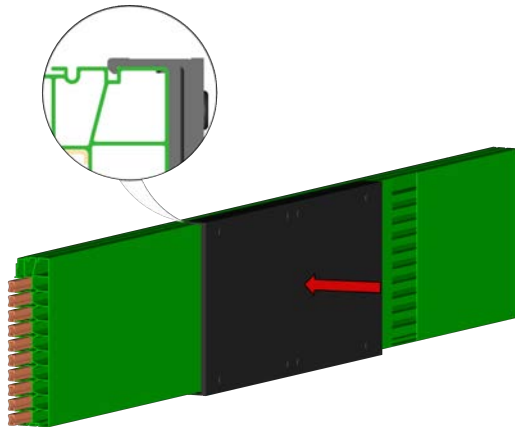

Line feed VNS

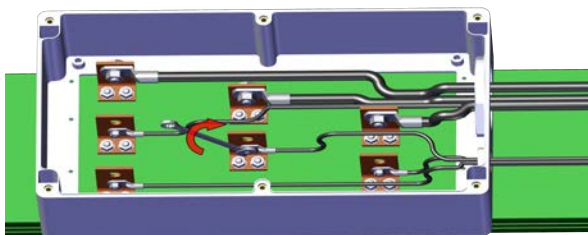

NOTICE!

- ▶ Tightening torque M6 = 7 Nm. Standard cable outlet on left, right also possible.

Step 3

Assembly steps:

1. Place the cover cap on the conductor rail and pay attention to cable routing.

Step 4

Assembly steps:

1. The cable outlet is at the side (left or right) of the cable connection.

TIPS AND RECOMMENDATIONS!

The connecting cables for the VLS line feeds can also be supplied pre-assembled (preferably rubber hose line H07RN-F/H07V-K).

Step 1

Required tools:

- ✂ Screwdriver
- ✂ Torque wrench

Assembly steps:

1. Open the cover on the installed line feed
2. Strip and cut the connecting wires as required.
3. Attach the cable lugs to the single wires and pass the connecting cable through the cable gland.
4. Screw the cable lugs to the connecting pins with the hexagon screws (M10, M5), lock washers and hexagon nuts.

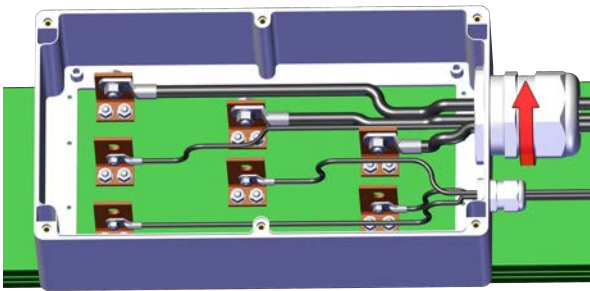
**NOTICE!**

Tightening torques in accordance with DIN VDE 0220 T2

- ▶ M10 = 44 Nm
- ▶ M5 = 5 Nm

Step 2

Assembly steps:

1. Tighten the cable gland until it is sealed against the connecting cable.

Step 3

Assembly steps:

1. Replace the cover and close the connection box.

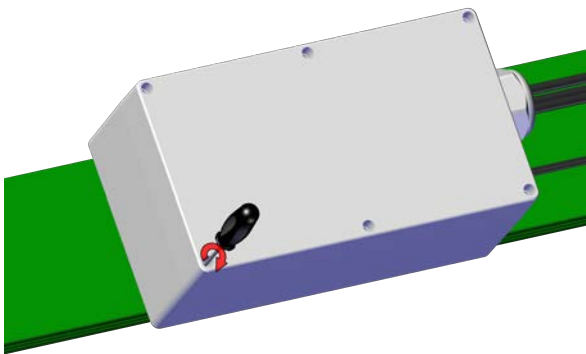
**End feed VEKS 10**

The end feed consists of a connection box and the VLS feed (see Line feed VLS)

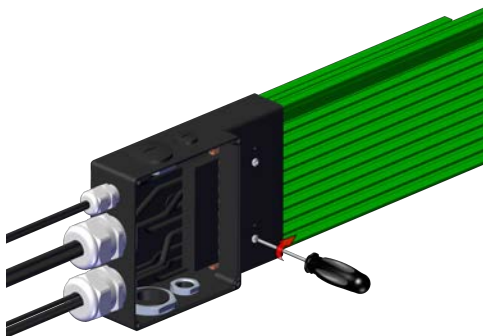
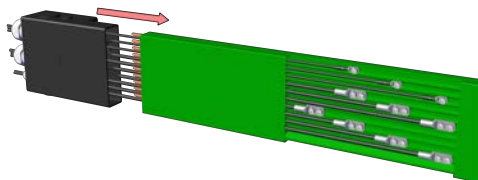
**Step 1**

Assembly steps:

1. Slide the end feed to the left or right onto one of the conductor rail ends of the VLS line feed.

Step 2

Required tools:

- ✂ Screwdriver

Assembly steps:

1. Secure the box with two screws. The screws are included in the packaging unit.
2. Then pull the cables through the insulation profile and the cable gland.

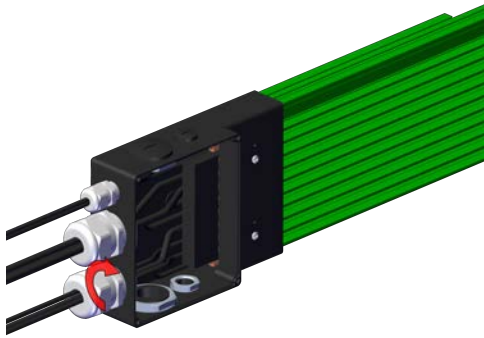
**NOTICE!**

- Observe the markings for right (R) and left (L).

Step 3

Assembly steps:

1. Tighten the cable gland until it is sealed against the connecting cable.

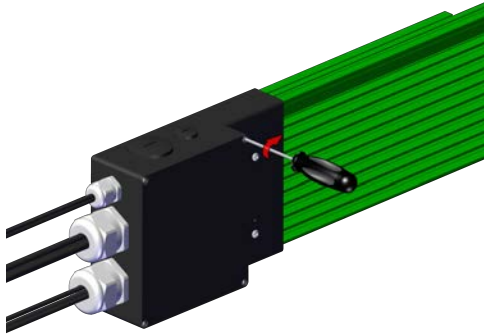
**Step 4**

Required tools:

- ✂ Screwdriver

Assembly steps:

1. Replace the cover and close the connection box.

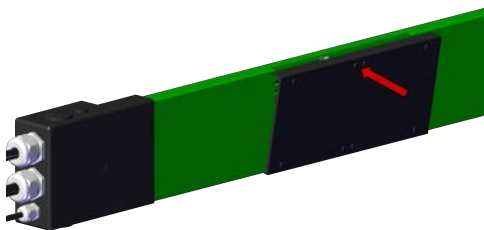
**Step 5**

Assembly steps:

1. Place the cover cap on the feed terminal.



7.5.3 Current collector

NOTICE!

Risk of damage by polarity reversal

- ▶ Observe the correct pole configuration of the current collector.

Holder for current collector

For the current collectors, fastening must be parallel to the longitudinal direction of the conductor rail and at a right angle to the contact surface.

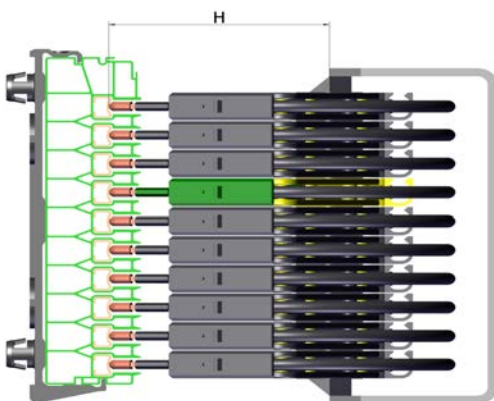

Step 1

Required tools:

- ✂ Tape measure

Assembly steps:

1. Attach the current collectors in the intended position.

NOTICE!

- ▶ The installation height "H" is shown in the table on page 71.

2. Slide the current collectors into the intended position.
3. Align the current collector with the phase center.

NOTICE!

- ▶ The permissible deviation is ± 1 mm.
- ▶ The permissible angle deviation is $\pm 1^\circ$ in all directions relative to the current collector.

4. Install the freely hanging part of the connecting cable with a minimum bending radius of $10 \times$ cable diameter.
5. Attach the current collectors to the specified towing points of the mobile users.

NOTICE!

Risk of damage to the current collectors

- ▶ The connection lines must not impede the mobility of the current collectors.



Tolerances

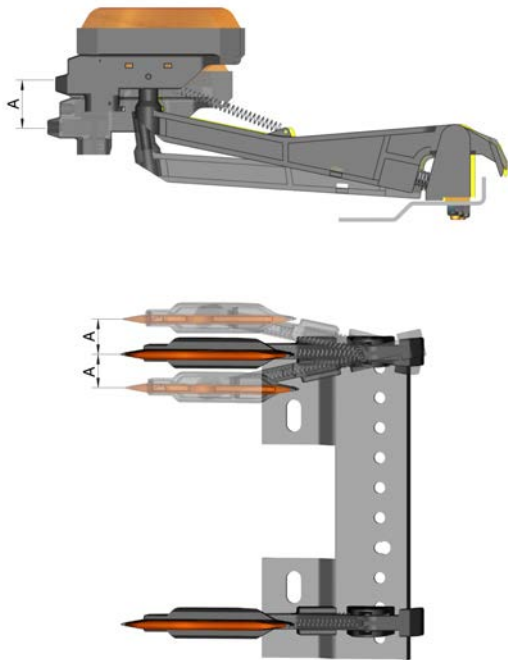

NOTICE!

- The permissible operational tolerances "A" for the stroke and deflection apply for current collectors and conductor system together. They compensate for the difference that results from imprecisions in the movement of the vehicle and possible installation offset at the conductor system.

Current collector types	Installation height "H" [mm]	Stroke and lateral deflection "A" [mm]
KST 30 to KST 63	85	± 20
KSTU 30 to KSTU 63	85	± 20
KESR 32-55 S-6-14 to 10-14 ⁽¹⁾	88	± 15
KESR 32-55 F-6-14 to 10-14 ⁽¹⁾	88	± 15
KESL 32-63 S-6-14 to 10-14 ⁽¹⁾	105	± 30
KESL 32-55 F-6-14 to 10-14 ⁽¹⁾	105	± 30
KESR 63 S-6-14 HS to 10-14 HS KBL + KBR ⁽¹⁾⁽²⁾	133	± 15
KESL 63 S-6-14 HS to 10-14 HS KBL + KBR ⁽¹⁾⁽²⁾	150	± 30

Use in deep-freeze warehouse (with special connection cable) on request.

⁽¹⁾ Use with flat plug connection and/or screw terminal.

⁽²⁾ Version with adapter plate and terminal block.



Connecting the power supply



DANGER!

Risk of fatal injuries from electrical current!

Contact with electrically live components may result in fatal injuries.

- ▶ De-energize the system before making any electrical connections.

Assembly steps:

1. Connect the feed terminal to the power supply (see Feed terminal 5.3.6).
2. Wire the current collectors to the consumers.

NOTICE!

Risk of damage by polarity reversal

- ▶ Observe the correct pole configuration of the current collector.

NOTICE!

- ▶ Switches, fuses and cables for wiring must be provided and installed by the customer.



7.5.4 Special components

Transfer funnel

The transfer funnels are equipped with a conductor rail section. The transfer funnel can be mounted on the left and right of prepared VKS straight sections.

NOTICE!

Risk of damage to the current collectors and transfer funnels.

- ▶ The stroke and deflection tolerances of the current collectors in the entrance area of the transfer funnels are limited to max. 10 mm in all directions. The speed is max. 100 m/min



Step 1

Required tools:

- ⌘ Wrench

Assembly steps:

1. Install the pillar according to the installation plan.
2. Attach the retaining plate to the pillar.

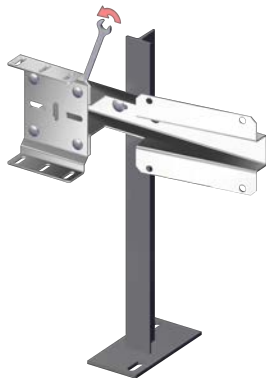

Step 2

Required tools:

- ⌘ Wrench

Assembly steps:

1. Attach the HRL hanger to the retaining plate.

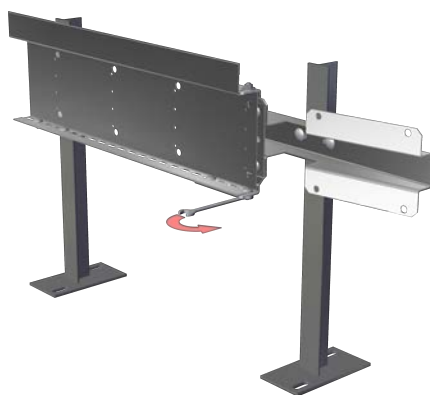

Step 3

Required tools:

- ⌘ Wrench

Assembly steps:

1. Screw the HRL support profile to the HRL hanger.
2. Mount the conductor rail in the HRL support profile (see 7.5.1 Conductor system).

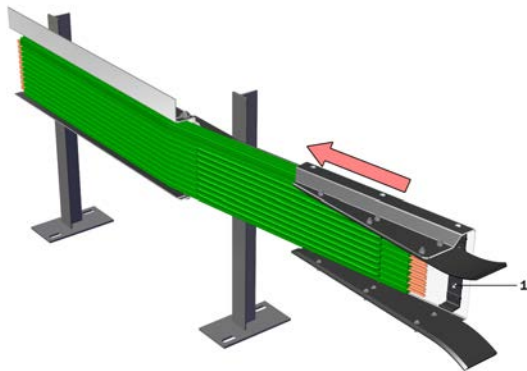

Step 4

Assembly steps:

1. Insert the three hangers into the funnel holes (1) and slide the funnel onto the conductor rail section.

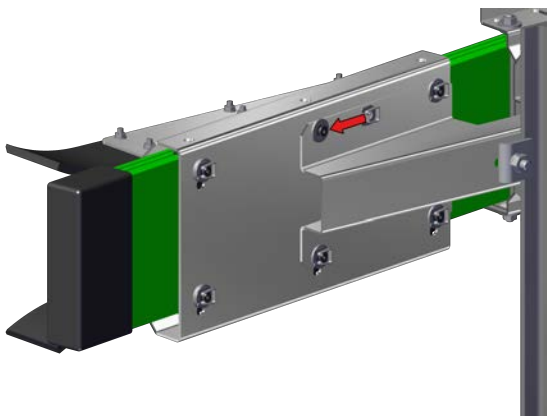

Step 5

Assembly steps:

1. Attach the transfer funnel to the retaining plate using the VKS hangers.

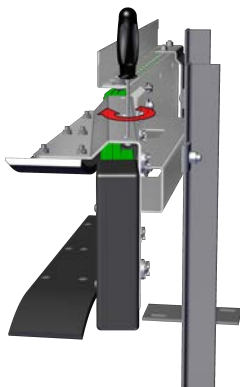

Step 6

Required tools:

- ✂ Screwdriver

Assembly steps:

1. Secure the hangers using the fixed point screws.

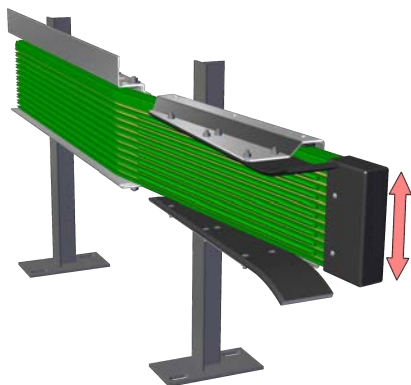

Step 7

Assembly steps:

1. Align the funnel unit accurately with the auxiliary support and fasten it.



Double line guide

The double line guide consists of an upper and a lower guide bar which is screwed to a conductor rail/support profile section in the head lane.

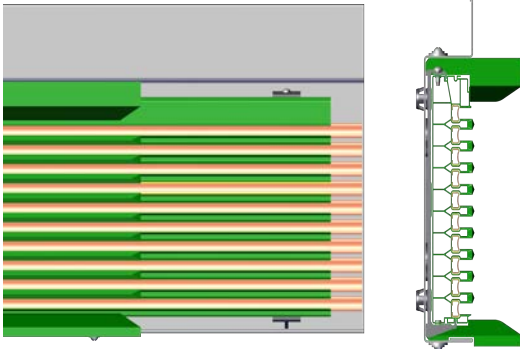

Step 1

Assembly steps:

1. During installation, align the double line guide with the current collector on the storage and retrieval system.
2. Glue in the PVC bars in the area of the line guides.

NOTICE!

- ▶ Do not mount VKS10 hangers and VTP10 hangers/connectors in the area of the line guide. See the corresponding installation plan for specific installation situations.



TIPS AND RECOMMENDATIONS!

It is recommended to create a reference lane using a reference device. Afterwards all lanes must be approached with this reference device. All current collector packages must then be aligned with the reference device. This ensures that all storage and retrieval systems can approach all lanes.



7.5.5 Path measuring systems

APOS

See separate installation instructions

WCS laminate code rail

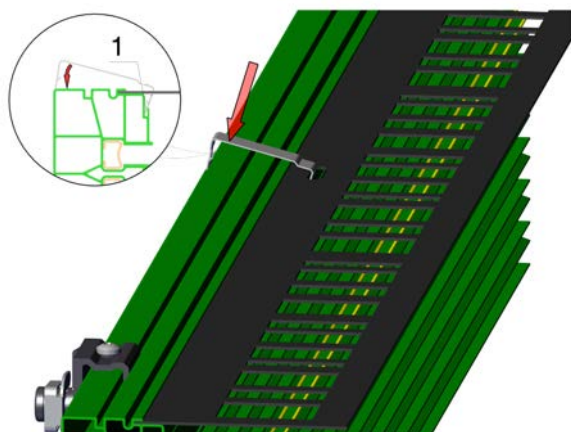

Step 1

Assembly steps:

1. Insert the plastic laminate tape into the groove (1) of the insulation profile.
2. Connect the insulation profile with the plastic laminate tape using the spring steel mounting brackets.

NOTICE!

- ▶ Ensure that the bracket engages first in the groove (1).

3. Fix the laminate tape in the middle of each conductor rail section with a screw.

NOTICE!

- ▶ The mounting distance is 200 mm (6.6 x 30 mm slot in the laminate every 200 mm)

Grounding of the code rail

The laminate rail must be connected to the system potential at least every 30 m (e.g. via Vahle support profile).

Bar code strip

In addition to the path measuring system, the self-adhesive bar code tape (BCB) can also be attached to the bar.

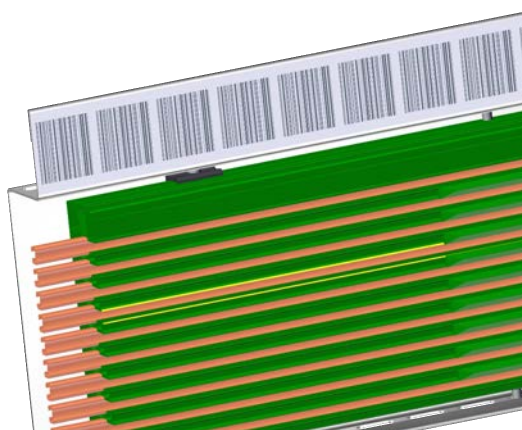

NOTICE!

- ▶ Check the surface: It must be smooth, dry and free of grease and dust.



7.5.6 Condition after the Installation



DANGER!

An adequate grounding as per IEC 60204-1/ 60204-32 must be ensured after the installation of the profile!



WARNING!

The responsible assembly manager must check the system for the following parts or situations after assembly and issue and sign an acceptance certificate!

- ▶ Check the general functionality of the system.
 - ▶ Clearances of the line transitions and transfers.
 - ▶ Open spaces and interfering edges.
 - ▶ Random sample checking of tightening torques.
 - ▶ Correct connection and routing of the cables.
 - ▶ Check of the feed terminals and their wirings.
 - ▶ Have all required parts been installed safely and according to instructions.
 - ▶ Current collector units.
-

7.5.7 Installation completion

After completing the assembly work, the plant is to be checked for functionality.

NOTICE!

- ▶ After the HRL support profile has been installed, proper grounding has to be ensured.
-



8 MALFUNCTIONS

8.1 Safety information about malfunctions



⚠ DANGER!

Electrical voltage on the system

Death or serious injury from electric shock.

- ▶ Before beginning any work, ensure that the system is free of voltage and remains so for the duration of the work. Observe the safety instructions!



⚠ WARNING!

Risk of injury in case of improper troubleshooting!

Improper troubleshooting may cause serious injuries or property damage.

- ▶ Ensure sufficient installation space before beginning any work.
- ▶ Switch off power supply, verify that the system is free of voltage, and secure against switching back on.

8.2 Procedure in the event of malfunction

General principle:

- In the event of malfunctions that pose an immediate hazard to persons or property, immediately activate the safety devices.
- Determine the cause of the fault.
- Notify the person in charge at the place of operation.



NOTICE!

The inspection and maintenance tasks listed in the technical documentation must be performed and documented regularly:

(location, spare part, task performed, date, name of inspector).

- ▶ Only persons with the required training, qualification and authorization may perform troubleshooting work on the system.



8.3 Troubleshooting table

Fault	Cause	Remedy
Conductor system transmits no/ too little current.	No supply voltage	Check voltage supply on site.
Conductor system burnt.	Current collector position on rail in- correct	Check current collector on site.



NOTICE!

Improper troubleshooting

Non-functional system

- ▶ In the event of faults and malfunctions, the cause of the fault must be determined and the damaged components must be replaced. After a fault has occurred and components have been replaced, an insulation resistance measurement in accordance with EN 60204-32 (section 18.3) must be carried out and a condition in compliance with the relevant standards must be restored before restarting.



9.1 Safety information about repairs



⚠ DANGER!

Before beginning any work, ensure that the system is free of voltage and remains so for the duration of the work. Observe the safety instructions in the section 3 Safety instructions!



⚠ WARNING!

Risk of injury due to improperly performed maintenance work!

Improper maintenance can result in serious personal injury or property damage.

- ▶ Ensure that there is sufficient clearance before starting work.
- ▶ Pay attention to order and cleanliness in the workplace!
- ▶ Follow the procedure according to 3 Safety instructions before starting work.



⚠ WARNING!

Danger due to insufficiently qualified persons!

Insufficiently qualified persons cannot assess the risks involved in operating the system and expose themselves and others to the risk of serious or fatal injuries.

- ▶ Have all work performed only by persons qualified for the task.
- ▶ Inadequately qualified persons should be kept away from the work area.



⚠ CAUTION!

Tripping hazard due to protruding parts

There is a tripping hazard during the work.

- ▶ Watch out for steps and holes in the floor when walking inside the work area and the danger zone. There must be no loose objects in the work area.



NOTICE!

The following service and maintenance tasks must be performed to maintain the warranty and avoid damage to the system in general. These must be performed by the owner.

- ▶ Contact the manufacturer for questions about service and maintenance work.
- ▶ The intervals indicated below depend on the conditions under which the system is operated. This is why only average intervals are given.



9.2 Conductor line



NOTICE!

Wear of the conductor rail thickness

Occasionally, the conductor rail may show increased wear due to irregular maintenance, highly frequented installations, difficult environmental conditions or inaccurate installation.

- ▶ Installations that may be affected by increased wear must be inspected regularly. For example, in the case of increased deposition of abrasive particles, unevenness in the running surface, in the course of the track or unevenness of suspension points.
- ▶ The minimum contact rail thickness must not be less than:
 - 0.3 mm with a contact pressure per current collector ≤ 7 N
 - 0.4 mm for a contact pressure per current collector > 7 N ≤ 12 N
 - 0.5 mm for a contact pressure per current collector > 12 N ≤ 35 N
 - 0.8 mm with a contact pressure per current collector > 35 N
- ▶ The measurement of the current bar strength can be done by Vahle specialists. For this purpose, please contact Vahle Customer Service (2.5 Customer service).

For normal use, the conductor system requires only little maintenance. The following tasks should be performed periodically however.

Interval	Service/monitoring	Personnel
daily	<ul style="list-style-type: none"> • Check safety equipment and operating behavior. 	Operator
monthly	<ul style="list-style-type: none"> • Visual inspection of general condition. Replace damaged/defective parts. • Check mechanical and electrical connections, especially at the feed terminals; re-tighten if necessary. • Remove small burns or discolorations on the contact surface by scouring with an abrasive pad (min. grit size 400). Do not use a powered brush. If removing the burns is not possible, then replace the relevant section of the conductor system. 	Technician/electrically qualified person
quarterly	<ul style="list-style-type: none"> • Vacuum off any dust deposits (e.g. from graphite contacts) and other particles. Cleaning acc. to section 3.4. 	Qualified persons

In case of damage to the conductor system, the associated components such as current collectors must be inspected for damage.

Replacing the conductor system

If the maintenance instructions are followed, a service life of 15-20 years can be achieved. This applies to systems that comply with the following maximum conditions:

- Passes: < 5 million
- Dry indoor systems with $T = 10-30^{\circ}$ C
- Compliance with the maintenance intervals

Higher-frequency conductor rail systems must be equipped with a conductor cross-section of at least 25 mm² (100 A copper) must be fitted. Other operating modes and ambient conditions can reduce the service life of the system.



9.3 Current collector

Interval	Service/monitoring	Personnel
daily	<ul style="list-style-type: none"> Check safety equipment and operating behavior. 	Operator
monthly	<p>Visual inspection of general condition. Replace damaged/defective parts.</p> <p>Mechanical control:</p> <ul style="list-style-type: none"> Check mobility of joints, bearings, and hinge pins. Inspection for mechanical damage of any type. Inspection of connection lines for damage and correct installation. The connection lines must not impede the mobility of the current collectors. <p>Electrical control:</p> <ul style="list-style-type: none"> Check for wear of graphite contacts, firm seat of all contact screws and cable attachments. Check remaining height of graphite contact. See 9.4 Cleaning. <p>Check pressing force:</p> <ul style="list-style-type: none"> Use a spring scale to pull the graphite contacts from the conductor system. The contact force must be about 5-7 N per graphite contact. If a check with a spring scale is not possible for design reasons, perform a visual check of the springs and verify that the contact force is even by individually lifting the graphite contact sockets. <p>Tightening torque:</p> <ul style="list-style-type: none"> The tightening torque of the contact screw (version for screw connection) is 1.2 Nm. 	Technician/electrically qualified person

In case of damage to the current collectors, inspect the conductor system for damage.



Lifetime

The wear of current collectors and graphite contacts depends on many different factors. These include temperature, humidity, current density, patination, and the amount of dirt and contamination of the application, especially the influence of foreign particles.

Until an optimal layer of patina is formed on the copper conductor systems, the first set of graphite contacts (initial delivery) usually has a somewhat shorter lifetime than subsequent sets.

Replacement intervals

Graphite contacts must be replaced in time so that the sockets of the graphite contacts cannot scrape on the conductor system housing or make contact with the edges of the connecting caps.

The residual heights of the graphite contacts are:

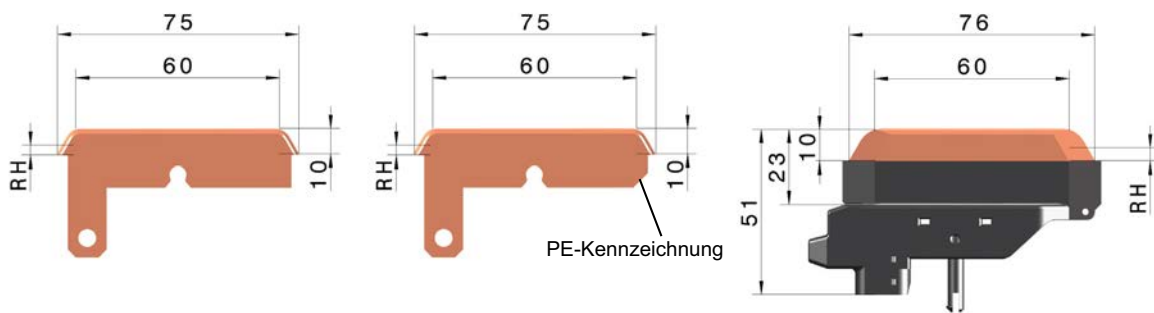

SK-KMK30-63-04-PH

SK-KMK30-63-04-PE

SK-MK55PH/PE

Type	Residual height RH [mm]
KST 30-KST 63 and KSTU 30-63	4.0
KESR and KESL 32-63 (MK 55/63)	3.5

Recommendation: Replace the entire current collector unit with every third replacement of the graphite contacts.



NOTICE!

Based on experience, the graphite contacts wear by one millimeter per 1000-1500 km of distance traveled.



9.4 Cleaning

After having been de-energized, the conductor system can be cleaned with a standard industrial vacuum cleaner to remove loose dust or graphite deposits.



CAUTION!

For maintenance and cleaning work where graphite contact dust may get into the ambient air, breathing protection must be used:

- ▶ Breathing protection mask acc. to EN 149, min. protection level FFP3.
Vahle product ID: 10017880
- ▶ Never blow out the mask with compressed air.
- ▶ Use vacuum with class m filter (according to TRGS 505).
- ▶ Do not eat, drink or smoke during work.

Dust in the vacuum cleaner bag or the air filter can be disposed of as commercial waste in the usual quantities (up to about 2 liters). Larger quantities must be disposed of in a controlled manner according to applicable law.

Cleaning the conductor system

Requirements:

- ✓ System free of voltage

Required tools:

- ✂ Standard industrial cleaner (e.g. Kärcher, Nilfisk)
- ✂ Cleaning brush with nylon bristles (e.g. Kärcher no. 2.863-146.0)
- ✂ Screwdriver set



9.4.1 Moving along the rail

Vacuum the conductor system and connecting caps, as well as the reversal points. Begin at the entry point of the system to be cleaned and clean the conductor system along its entire length.

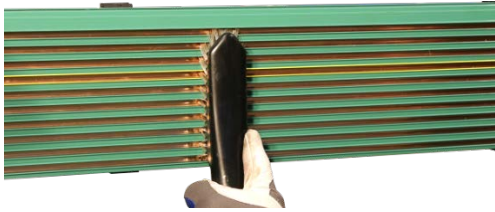

Conductor system sections

1. Vacuum the sections with the cleaning brush and vacuum cleaner.

Connecting caps

1. Vacuum the connecting caps with the cleaning brush and vacuum cleaner, knocking the back of the connecting caps with the ball of the hand.

Knock the connecting caps at least twice, with three knocks each.

If this is not possible due to design, then knock the connecting caps from the front side.

NOTICE!

Clean especially the reversal points on the sections.



Connector cap, moving along the rail, before



Connecting cap, moving along the rail, after





Reversal points, moving along the rail, before



Reversal points, moving along the rail, after

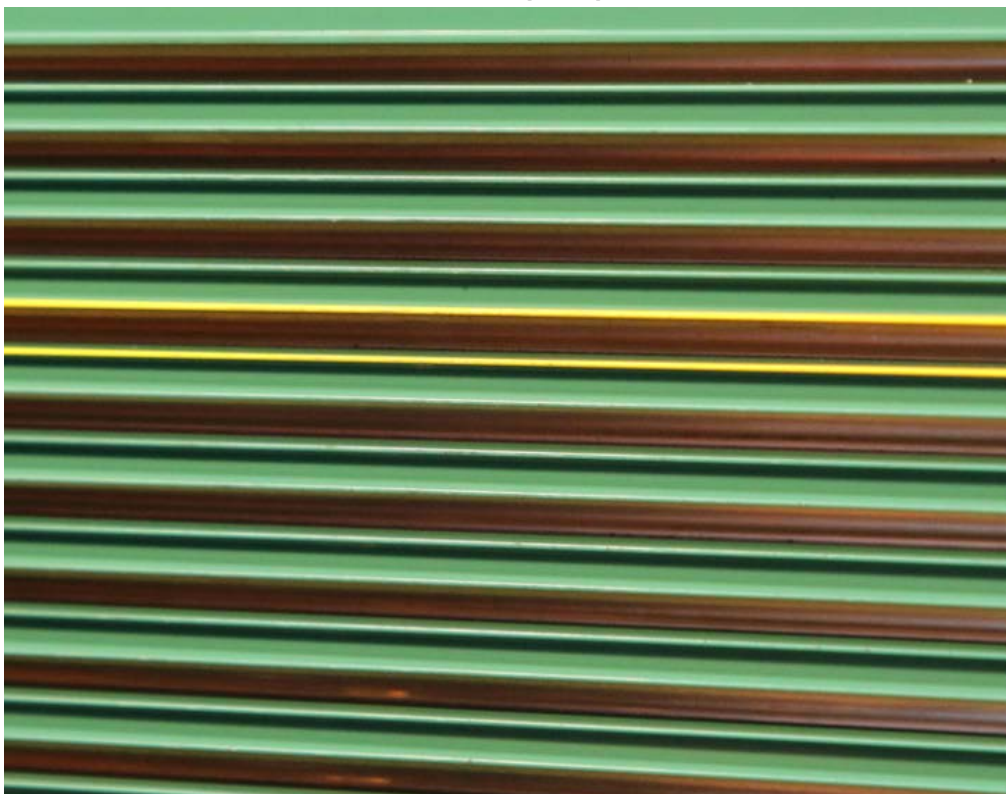



9.4.2 Mast assembly

Vacuum the conductor system and connecting caps as well as the lower end cap. Begin cleaning at the top of the conductor system on the mast and clean the entire unit to the lowest part (end cap):



Conductor system sections

1. Vacuum the sections with the cleaning brush and vacuum cleaner.



Connecting caps

1. Vacuum the connecting caps with the cleaning brush and vacuum cleaner, knocking the back of the connecting caps with the ball of the hand.

Knock the connecting caps at least twice, with three knocks each.

If this is not possible due to design, then knock the connecting caps from the front side.





Connecting caps, mast assembly, before

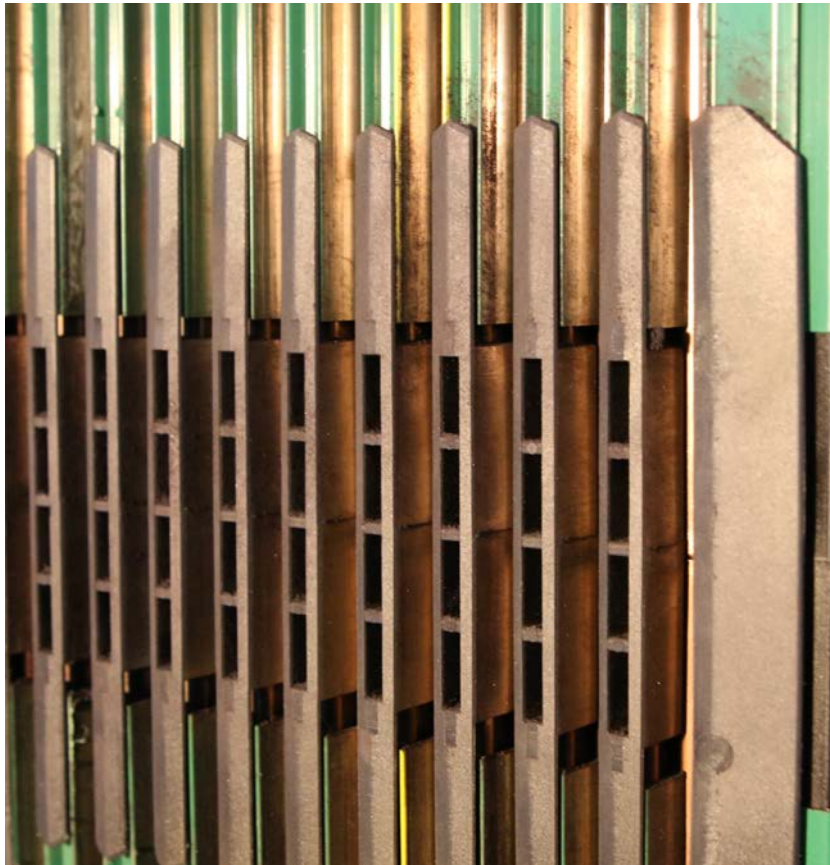

Connecting caps, mast assembly, after

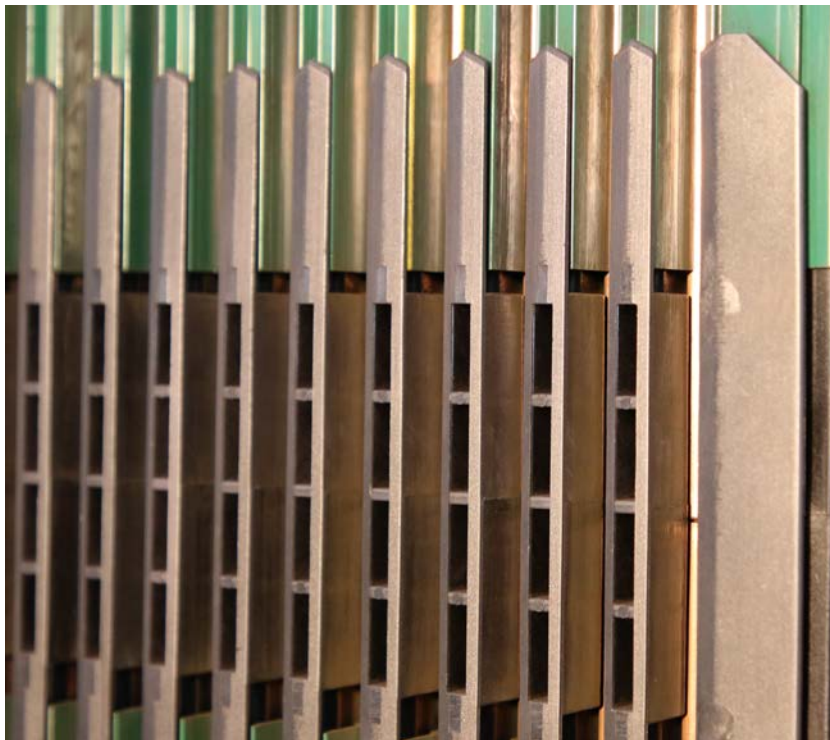

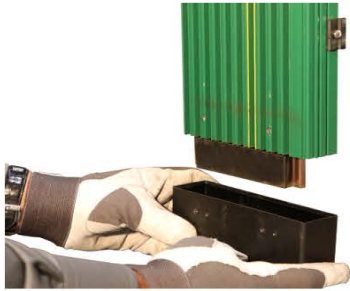
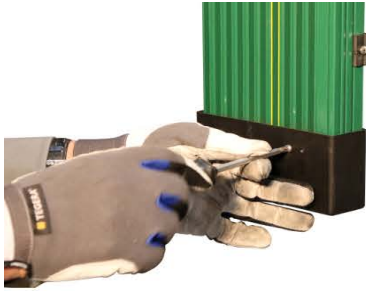

End cap

1. Remove the lower end cap.
2. Vacuum the end cap.
3. Remove the leakage path extension.
4. Knock out the leakage path extension.
5. Install the leakage path extension and the end cap.



9.4.3 Result of cleaning

After cleaning, the conductor system should be free of loose and foreign particles. Repeat the process if necessary.



TIPS AND RECOMMENDATIONS!

Due to external soiling and influence of particles (fine dirt, liquids, wood chips, grease, abrasion dust), we recommend cleaning the floor regularly.

For most assemblies, the steel construction (around the feed terminal) should also be cleaned regularly.

9.4.4 Special cleaning procedures

General information on wet cleaning

Large amounts of grease or soiling by other wet substances may have the following negative impact on the conductor rail:

- Increase of transition resistance between graphite contact and conductor rail due to adhesive contamination of the surfaces (degrading contact)
- Influence on graphite contact lifetime

In case of strong soiling as described above, it is recommended to wet-clean the conductor rail using the following agents:

Rivolta S.LX. 1000 (suitable for oily substances)



NOTICE!

The conductor rail must only be used with manufacturer-approved cleaners.

The cleaners are suitable for the relevant plastics and usually do not degrade them.

- ▶ **RIVOLTA S.LX. 1000 (for conductor rails with oily contamination)**
- ▶ Generally suitable for the food industry (NSF-K2 listed)
- ▶ For excerpts from the safety data sheet please see: “12”, or detailed information at the following link:
www.rivolta.de

Cleaning (oil-contaminated conductor rail)

- ✂ Rivolta S.LX 1000
- 1. Spray cleaner directly on the oily (soiled) conductor rail.
- 2. No further treatment necessary. (Cleaner decomposes contamination and evaporates)



9.5 Spare parts

The spare parts are for the mechanical part of the installation exclusively. Please see the relevant sales receipt or routing diagram.

For the ordering address, please see chapter 1.5, customer service. Please indicate Ident-No.

Use of third-party, copied, or non-approved components voids our warranty.



WARNING!

No liability in case of unauthorized changes, modifications, or accessories!

Changes or modifications to the delivered product require the permission of the manufacturer. Genuine spare parts and manufacturer-approved accessories provide safety. The use of non-approved parts voids any liability of the manufacturer.

- ▶ Always consult the manufacturer first!
-



9.6 Wear parts

Graphite contacts

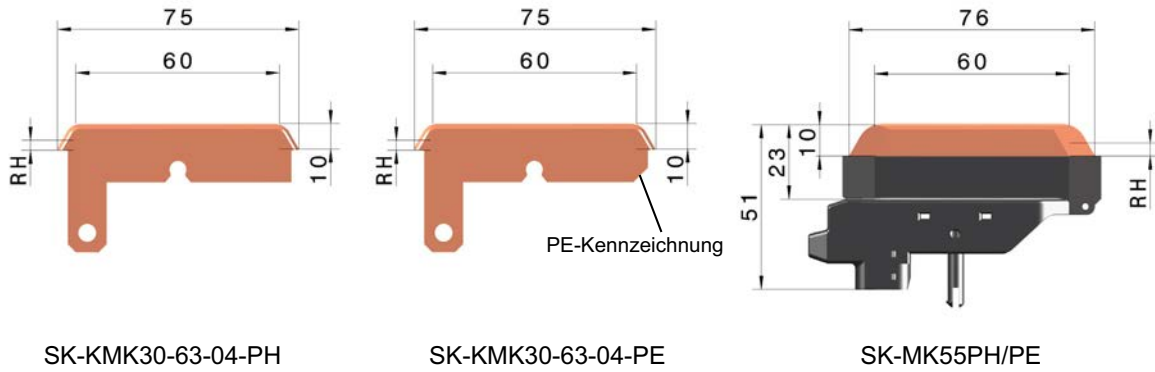

SK-KMK30-63-04-PH

SK-KMK30-63-04-PE

SK-MK55PH/PE

Type	for current collector	Weight [kg]	RH [mm]	Thickness [mm]	ID no.
SK-KMK30-63-04-PH	KST 30-KST 63 and KSTU 30-63	0.031	4.00	4.40	154 440
SK-KMK30-63-04-PE	KST 30-KST 63 and KSTU 30-63	0.031	4.00	4.40	154 453
SK-MK55F-31-14	KESR 32-55F and KESL 32-55F	0.040	3.50	4.20	780 920
SK-MK63S-31-14	KESR 32-63S and KESL 32-96S	0.046	3.50	4.20	780 921

Springs

Pressure spring DF

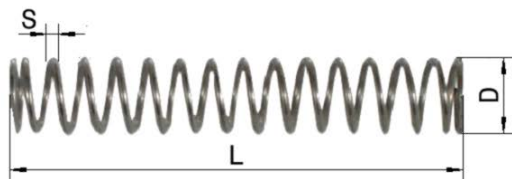

Tension spring ZF

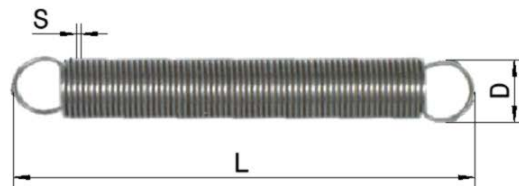

Type	for current collector	S [mm]	D [mm]	L [mm]	ID no.
DF2	KESR 32-63	0.90	7.70	43.00	153 848
DF4	KESL 32-63	1.10	6.40	41.00	157 312
RF3	KESR 32-53 KESL 32-63	0.40	4.40	31.00	153 849



Current collector KESR / KESL



KESR

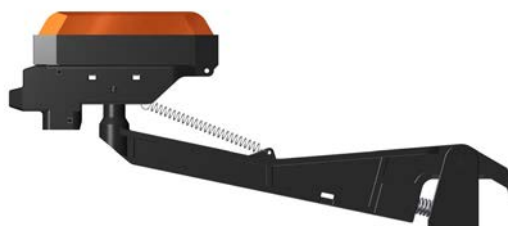

KESL

Type	Weight [kg]	Pin allocation	ID no.
SA-KESR32-55F/14PH	0.006	Phase	143 111
SA-KESR32-55F/14PE	0.006	PE	143 112
SA-KESR32-55S/14PH	0.066	Phase	143 120
SA-KESR32-55S/14PE	0.066	PE	143 121
SA-KESL32-63S/14PH	0.084	Phase	168 395
SA-KESL32-63S/14PE	0.084	PE	142 880

...- 55F = flat connector

...- 55S = screw terminal

Current collector KST



Type	Weight [kg]	Current [A]	Connecting cable		ID no.	
			A [mm ²]	d max.[mm]	Phase black	PE yellow
SA-KST30PE-04A-2000	0.240	30	2.50	5	-	152 086
SA-KST30PH-04C-2000	0.240	30	2.50	5	152 085	-
SA-KST55PE-04D-2000	0.368	55	6.00	11	-	154 439
SA-KST55PH-04C-2000	0.368	55	6.00	11	154 438	-
SA-KST63PE-2000	0.394	63	10.00	9	-	156 792
SA-KST63PH-2000	0.394	63	10.00	9	156 791	-



NOTICE!

Please contact the manufacturer if you are unable to identify desired spare parts with this overview, e.g. when custom components are used.

10 DISASSEMBLY AND DISPOSAL

10.1 Preparation for disassembly

- Switch off the system and secure it against switching back on.
- Physically disconnect the entire power supply from the system.
- Loosen and remove all screws.



DANGER!

Danger of death due to electrical current!

Contact with live parts can result in life-threatening injuries.

- ▶ Make sure that the relevant components are not live or under voltage, and that there is no unauthorized approximation.

10.1.1 Disassembly

During disassembly, always observe the information in section 3.3.1 .



WARNING!

Risk of death from improper replacement or removal!

Errors during the removal or replacement of components may cause life-threatening situations or significant property damage

- ▶ Observe the safety instructions before beginning any removal work.



CAUTION!

All accessories must be checked for wear.

Only defect-free parts may be reused.

- ▶ Use only genuine VAHLE spare parts.

10.2 Disposal

General information

Current national local regulations are decisive for disposing / recovering (recycling) assemblies, machines and systems.



NOTICE!

Danger from incorrect disposal / operator responsibility

Risk of environmental damage / loss of valuable raw materials

- ▶ Incorrect disposal can lead to environmental damage.
- ▶ **Electronic scrap is hazardous waste!**
- ▶ The most recent, valid guidelines, laws and regulations of the respective economic area or country in which assemblies are disposed of / recycled apply.
- ▶ The operator of the products is responsible for proper disposal / recycling.
- ▶ Old electrical appliances contain valuable raw materials. **These must not be deposited in residual waste!**

Disposal instructions

Individual product parts to be disposed of must be separated according to their nature. Currently valid on-site regulations must be observed.

Overview of parts / sub-assemblies that must be disposed of separately:

- Electronic scrap (circuit boards)
- Batteries and accumulators
- Plastic
- Sheet metal
- Copper
- Aluminum

Information about the WEEE Directive (2012/19/EU)

The WEEE directive does **not** apply to the described products, **because the products fall under the Article 2 "Scope" exception**. the described products are used in large industrial tools, stationary large-scale systems and moving machines that are not intended for road traffic and are made available and designed for professional use (B2B) only.

Manufacturer's obligation to provide information

(according to ElektroG, Germany)

Options for the return, disposal and recovery (recycling) of old devices

- The latest, valid guidelines, laws and regulations on site apply.
- The operator, as a professional user of the products, is responsible for properly disposing or recycling of (old) products.
- Contact a recovery, recycling or disposal company that specializes in electronic waste.

Note on data protection

- The operator or his employees are **personally responsible** for ensuring compliance with data protection.
- Personal data that is present on the assembly to be disposed of or stored in the assembly must be removed by the operator or safely and permanently deleted ->**the operator is personally responsible.**
 - **Data on the module:** Stickers, labels, etc.
 - **Data stored in the module / device:** electronically stored data, etc.

Meaning of the symbol "crossed out garbage can with black bars"

Fig. 10-1 Symbol

- Symbol according to WEEE Directive 2012/19 / EU or ElektroG (Germany)
- If possible, the symbol is attached to the nameplate. Otherwise, the symbol can be found on the product packaging.
- Meaning of the symbol:
 - Symbol for the separate gathering / collection of electrical and electronic equipment
 - > The product must not be disposed of in unsorted waste, but must be brought to separate collection points for disposal / recovery (recycling).
 - > The black bar under the symbol indicates that the product was placed on the market after August 13, 2005.

11 PROTECTIVE MEASURES

11.1 EU conformity declaration

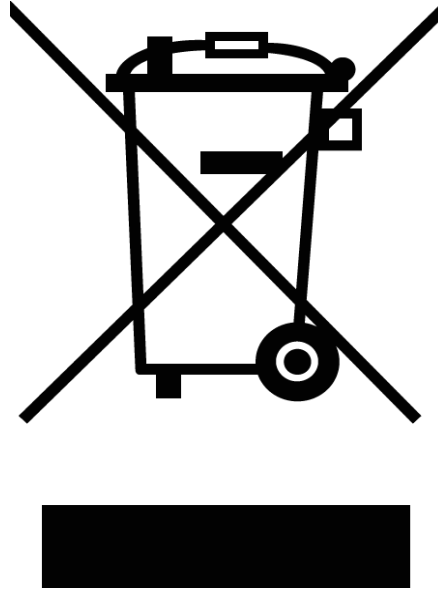

EU-Konformitätserklärung

Paul Vahle GmbH & Co. KG, Westicker Str. 52, D-59174 Kamen

Hiermit erklären wir, dass die nachfolgend bezeichneten Produkte in der von uns in den Verkehr gebrachten Ausführung den unten genannten einschlägigen EU-Richtlinien entspricht. Durch nicht mit uns abgestimmte Änderung verliert diese Erklärung ihre Gültigkeit.

Artikelgruppe	74
Produkt	Kompakt - Schleifleitung
Baureihe	VKS 10 einschl. Zubehör
Einschlägige EU-Richtlinie	2014 / 35 / EU (Niederspannungsrichtlinie)
Anbringung der CE-Kennzeichnung:	96
Folgende harmonisierte Normen bzw. sonstige technische Normen und Spezifikationen wurden angewandt:	
EN 60204-1:	2018
EN 60204-32:	2008

Diese Erklärung beinhaltet keine Zusicherung von Eigenschaften.
Die Sicherheitshinweise der mitgelieferten Produktdokumentationen sind zu beachten.

Kamen, 26.10.2021

Michael Heitmann
Leiter Testing, Services & Qualitätsmanagement

11.2 UKCA



UKCA - Declaration of conformity

Paul Vahle GmbH & Co. KG, Westicker Str. 52, D-59174 Kamen (Germany)

We herewith declare that the products specified hereafter conform to the relevant UK regulations. This declaration will be void when amendments not approved by us.

Product Group	74
Product	PVC Enclosed Conductor System
Type	VKS 10 incl. accessories
Relevant UK Regulation	Electrical Equipment (Safety) Regulation 2016
First CE / UKCA - marking	1996 /2022

The following harmonized standards respectively other technical norms and Specifications have been applied:

EN 60204-1:	2018
EN 60204-32:	2008

This declaration is not an assurance of properties.

The safety hints mentioned in the product documentation must be followed.

Kamen, 21.10.2022

Michael Heitmann
Director Quality Management

INDEX

A

Activate 9

D

Determine absence of voltage 9

E

Electrically qualified person 12

G

Grounding and short-circuiting 9

I

Information on the instructions 4

Installation 10

O

Operating company 11

Operation 56

Owner obligations 11

Q

Qualifications 12

R

Requirements of personnel 12

S

safety aspects 8

Safety information 5

Storage temperature 53

Switch on again 9

Symbols 4

T

Technical condition 11

Transport 53

U

Unloading 53

12 OTHER DOCUMENTS

12.1 Safety Data Sheet RIVOLTA-Cleaner



SAFETY DATA SHEET

According to Regulation (EC) No. 1907/2006 (REACH) Article 31, Annex II as amended.

SECTION 1: Identification of the substance/mixture and of the company/undertaking

1.1 Product identifier

Product name: Rivolta S.L.X. 1000

1.2 Relevant identified uses of the substance or mixture and uses advised against

Identified uses: Solvent-based cleaner
Uses advised against: No uses advised against identified.

1.3 Details of the supplier of the safety data sheet

Manufacturer / Supplier Bremer & Leguil GmbH
 Am Burgacker 30 - 42
 47051 Duisburg
 info@bremer-leguil.de
 www.bremer-leguil.de

Telephone: +49 (0)203 / 9923-0
Fax: +49 (0)203 / 25901

Contact Person: Bremer & Leguil GmbH - Product Safety Management
E-mail: product-safety-management@bremer-leguil.de

1.4 Emergency telephone number: +49 (0) 6131 / 19240 (Giftinformationszentrum Mainz)

SECTION 2: Hazards identification

2.1 Classification of the substance or mixture

|| The product has not been classified as hazardous and does not need to be labelled according to regulation (EU) no 1272/2008 (CLP).

Hazard summary

Physical Hazards: No data available.

2.2 Label Elements not applicable

2.3 Other hazards:

By handling of mineral oil products and chemical products no particular hazard is known when normal precautions (item 7) and personal protective equipment (item 8) are kept. The product may not be released into the environment without control.

Issue Date: 23.05.2014
 Revision Date: 07.09.2015
 Supersedes Date: 07.09.2015
 SDS_DE - EN - 000000000600448134

Version: 4.0

1/9



Product name: Rivolta S.L.X. 1000

SECTION 3: Composition/information on ingredients

3.2 Mixtures

General information: The components are not hazardous or are below required disclosure limits.

SECTION 4: First aid measures

General: Change clothes and shoes contaminated or soaked by the product. Never put rags contaminated by the product into clothing pockets.

4.1 Description of first aid measures

Inhalation: Supply fresh air; consult doctor in case of symptoms.

Eye contact: Promptly wash eyes with plenty of water while lifting the eye lids.

Skin Contact: Wash with soap and water. The product is not skin irritating.

Ingestion: Rinse mouth thoroughly.

4.2 Most important symptoms and effects, both acute and delayed: May cause skin and eye irritation.

4.3 Indication of any immediate medical attention and special treatment needed

Hazards: No data available.

Treatment: Get medical attention if symptoms occur.

SECTION 5: Firefighting measures

5.1 Extinguishing media

Suitable extinguishing media: CO₂, fire extinguishing powder or fog like water spraying. Extinguish larger fires with alcohol resistant foam or spray water with suitable surfactant added

Unsuitable extinguishing media: Water with a full water jet.

5.2 Special hazards arising from the substance or mixture: During fire, gases hazardous to health may be formed.

5.3 Advice for firefighters

Special fire fighting procedures: No data available.

Special protective equipment for fire-fighters: Self-contained breathing apparatus and full protective clothing must be worn in case of fire.

Issue Date: 23.05.2014
 Revision Date: 07.09.2015
 Supersedes Date: 07.09.2015
 SDS_DE - EN - 00000000600448134

Version: 4.0

2/9



Product name: Rivolta S.L.X. 1000

SECTION 6: Accidental release measures

- 6.1 Personal precautions, protective equipment and emergency procedures:** In case of spills, beware of slippery floors and surfaces.
- 6.2 Environmental Precautions:** Prevent from spreading (e.g. by binding or oil barriers).
- 6.3 Methods and material for containment and cleaning up:** Absorb with liquid-binding material (sand, diatomite, acidbinders, universal binders, sawdust).
- 6.4 Reference to other sections:** See Section 8 of the SDS for Personal Protective Equipment. See Section 7 for information on safe handling See Section 13 for information on disposal.

SECTION 7: Handling and storage:

- 7.1 Precautions for safe handling:** Provide adequate ventilation. Observe good industrial hygiene practices. Do not eat, drink or smoke when working with the product. Take usual precautions when handling mineral oil products or chemical products.
- 7.2 Conditions for safe storage, including any incompatibilities:** Local regulations concerning handling and storage of waterpolluting products have to be followed. Prevent formation of aerosols.
- 7.3 Specific end use(s):** not applicable
- Storage Class:** 12, Non-combustible liquids

SECTION 8: Exposure controls/personal protection

8.1 Control Parameters

Occupational Exposure Limits

None of the components have assigned exposure limits.

8.2 Exposure controls

Appropriate engineering controls:

Provide adequate ventilation. Ventilation rates should be matched to conditions. If applicable, use process enclosures, local exhaust ventilation, or other engineering controls to maintain airborne levels below recommended exposure limits. If exposure limits have not been established, maintain airborne levels to an acceptable level.

Individual protection measures, such as personal protective equipment

General information:

Wash hands before breaks and after work. Use personal protective equipment as required. Personal protection equipment should be chosen according to the CEN standards and in discussion with the supplier of the personal protective equipment. The usual precautionary measures should be adhered to in handling the chemicals or the mineral oil products.

Issue Date: 23.05.2014
 Revision Date: 07.09.2015
 Supersedes Date: 07.09.2015
 SDS_DE - EN - 00000000600448134

Version: 4.0

3/9



Product name: Rivolta S.L.X. 1000

Eye/face protection:	Safety glasses (EN 166) recommended during refilling.
Skin protection	
Hand Protection:	Nitrile butyl rubber (NBR). Avoid long-term and repeated skin contact. Suitable gloves can be recommended by the glove supplier. Use skin protection cream for preventive skin protection. Protective gloves, where permitted in acc. to safety directions. The exact break through time has to be found out by the manufacturer of the protective gloves and has to be observed.
Other:	Do not carry cleaning cloths impregnated with the product in trouser pockets. Wear suitable protective clothing.
Respiratory Protection:	Seek advice from local supervisor. Ensure good ventilation/exhaustion at the workplace. Avoid breathing vapour/ aerosol.
Thermal hazards:	No data available.
Hygiene measures:	Always observe good personal hygiene measures, such as washing after handling the material and before eating, drinking, and/or smoking. Routinely wash work clothing to remove contaminants. Discard contaminated footwear that cannot be cleaned.
Environmental Controls:	No data available.

SECTION 9: Physical and chemical properties

9.1 Information on basic physical and chemical properties

Appearance

Physical state:	liquid
Form:	liquid
Color:	Colorless
Odor:	Slight
Odor Threshold:	No data available.
pH:	not applicable
Freezing point:	No data available.
Boiling Point:	> 60 °C
Flash Point:	not applicable
Evaporation Rate:	No data available.
Flammability (solid, gas):	No data available.
Flammability Limit - Upper (%)–:	
Flammability Limit - Lower (%)–:	
Vapor pressure:	230 hPa
Vapor density (air=1):	No data available.
Density:	1,54 g/cm ³ (15 °C) (DIN 51757)
Solubility(ies)	
Solubility in Water:	The product is insoluble in water.
Solubility (other):	No data available.

Issue Date: 23.05.2014
 Revision Date: 07.09.2015
 Supersedes Date: 07.09.2015
 SDS_DE - EN - 00000000600448134

Version: 4.0

4/9



Product name: Rivolta S.L.X. 1000

Partition coefficient (n-octanol/water):	No data available.
Autoignition Temperature:	No data available.
Decomposition Temperature:	No data available.
Flow time	No data available.
Explosive properties:	No data available.
Oxidizing properties:	No data available.
9.2 Other information	No data available.

SECTION 10: Stability and reactivity

10.1 Reactivity:	Stable under normal temperature conditions and recommended use.
10.2 Chemical Stability:	No data available.
10.3 Possibility of hazardous reactions:	None under normal conditions.
10.4 Conditions to avoid:	Avoid heat or contamination.
10.5 Incompatible Materials:	Strong oxidizing substances. Strong acids. Strong bases.
10.6 Hazardous Decomposition Products:	Thermal decomposition or combustion may liberate carbon oxides and other toxic gases or vapors.

SECTION 11: Toxicological information

11.1 Information on toxicological effects

Acute toxicity

Oral

Product: Not classified for acute toxicity based on available data.

Dermal

Product: Not classified for acute toxicity based on available data.

Inhalation

Product: Not classified for acute toxicity based on available data.

Repeated dose toxicity

Product: No data available.

Skin Corrosion/Irritation:

Product: No data available.

Serious Eye Damage/Eye Irritation:

Product: No data available.

Issue Date: 23.05.2014
 Revision Date: 07.09.2015
 Supersedes Date: 07.09.2015
 SDS_DE - EN - 00000000600448134

Version: 4.0

5/9



Product name: Rivolta S.L.X. 1000

Respiratory or Skin Sensitization:

Product: No data available.

Germ Cell Mutagenicity

In vitro

Product: No data available.

In vivo

Product: No data available.

Carcinogenicity

Product: No data available.

Reproductive toxicity

Product: No data available.

Specific Target Organ Toxicity - Single Exposure

Product: No data available.

Specific Target Organ Toxicity - Repeated Exposure

Product: No data available.

Aspiration Hazard

Product: No data available.

Other Adverse Effects:

No data available.

SECTION 12: Ecological information

12.1 Toxicity

Acute toxicity

Fish

Product: No data available.

Aquatic Invertebrates

Product: No data available.

Chronic Toxicity

Fish

Product: No data available.

Aquatic Invertebrates

Product: No data available.

Toxicity to Aquatic Plants

Product: No data available.

12.2 Persistence and Degradability

Biodegradation

Issue Date: 23.05.2014

Revision Date: 07.09.2015

Supersedes Date: 07.09.2015

SDS_DE - EN - 00000000600448134

Version: 4.0

6/9



Product name: Rivolta S.L.X. 1000

Product: No data available.

12.3 Bioaccumulative Potential

Product: No data available.

12.4 Mobility in Soil: No data available.

12.5 Results of PBT and vPvB assessment: No data available.

12.6 Other Adverse Effects: No data available.

Water Hazard Class (WGK): WGK 1: slightly water-endangering.

SECTION 13: Disposal considerations

13.1 Waste treatment methods

General information: Dispose in accordance with all applicable regulations.

Disposal methods: Do not empty into drains; dispose of this material and its container in a safe way. When storing used products, ensure that the waste categories and mixing instructions are observed.

European Waste Codes

14 06 02*: other halogenated solvents and solvent mixtures

SECTION 14: Transport information

ADR/RID

14.1 UN Number: –
 14.2 UN Proper Shipping Name: –
 14.3 Transport Hazard Class(es)
 Class: Non-dangerous goods
 Label(s): –
 Hazard No. (ADR): –
 Tunnel restriction code: –
 14.4 Packing Group: –
 14.5 Environmental hazards: –
 14.6 Special precautions for user: –

Issue Date: 23.05.2014
 Revision Date: 07.09.2015
 Supersedes Date: 07.09.2015
 SDS_DE - EN - 00000000600448134

Version: 4.0

7/9



Product name: Rivolta S.L.X. 1000

ADN

14.1 UN Number: –
 14.2 UN Proper Shipping Name: –
 14.3 Transport Hazard Class(es)
 Class: Non-dangerous goods
 Label(s): –
 14.3 Packing Group: –
 14.5 Environmental hazards: –
 14.6 Special precautions for user: –

IMDG

14.1 UN Number: –
 14.2 UN Proper Shipping Name: –
 14.3 Transport Hazard Class(es)
 Class: Non-dangerous goods
 Label(s): –
 EmS No.: –
 14.3 Packing Group: –
 14.5 Environmental hazards: –
 14.6 Special precautions for user: –

IATA

14.1 UN Number: –
 14.2 Proper Shipping Name: –
 14.3 Transport Hazard Class(es):
 Class: Non-dangerous goods
 Label(s): –
 14.4 Packing Group: –
 14.5 Environmental hazards: –
 14.6 Special precautions for user: –

14.7 Transport in bulk according to Annex II of MARPOL73/78 and the IBC Code: not applicable.

SECTION 15: Regulatory information

15.1 Safety, health and environmental regulations/legislation specific for the substance or mixture:

EU Regulations

Regulation (EC) No. 2037/2000 Substances that deplete the ozone layer: none

Regulation (EC) No. 850/2004 on persistent organic pollutants: none

National Regulations

Water Hazard Class (WGK): WGK 1: slightly water-endangering.

15.2 Chemical safety assessment: No Chemical Safety Assessment has been carried out.

Issue Date: 23.05.2014
 Revision Date: 07.09.2015
 Supersedes Date: 07.09.2015
 SDS_DE - EN - 00000000600448134

Version: 4.0

8/9



Product name: Rivolta S.L.X. 1000

SECTION 16: Other information

Revision Information: Vertical lines in the margin indicate an amendment.

Wording of the H-statements in section 2 and 3

none

Other information: The classification is in line with current EC lists. It is expanded, however, by information from technical literature and by information furnished by supplier companies. The classification results from the Conventional Method mentioned in regulation EU 1272/2008 (CLP).

Revision Date: 07.09.2015

Disclaimer: The data contained in this safety data sheet are based on our current knowledge and experience and are given to the best of our knowledge and belief. It characterizes the product only with regard to safety requirements for handling, transport and disposal. The data do not describe the product's properties (tech. product specification). Neither should any agreed property nor the suitability of the product for any specific technical application be deduced from the data contained in this safety data sheet. Modifications on this document are not allowed. The data are not transferable to other products. In the case of mixing the product with other products or in the case of processing, the data in this safety data sheet are not necessarily valid for the new-made material. It is the responsibility of the recipient of the product to observe federal, state and local law. Please contact us to obtain up-to-date safety data sheets. This document was issued electronically and has no signature.

Issue Date: 23.05.2014
Revision Date: 07.09.2015
Supersedes Date: 07.09.2015
SDS_DE - EN - 00000000600448134

Version: 4.0

9/9



Paul Vahle GmbH & Co. KG

Westicker Str. 52
59174 Kamen
Germany

+49 2307 7040
info@vahle.com
vahle.com

You can find your local contact at:

vahle.com/contact



TECHNICAL DOCUMENTATION