

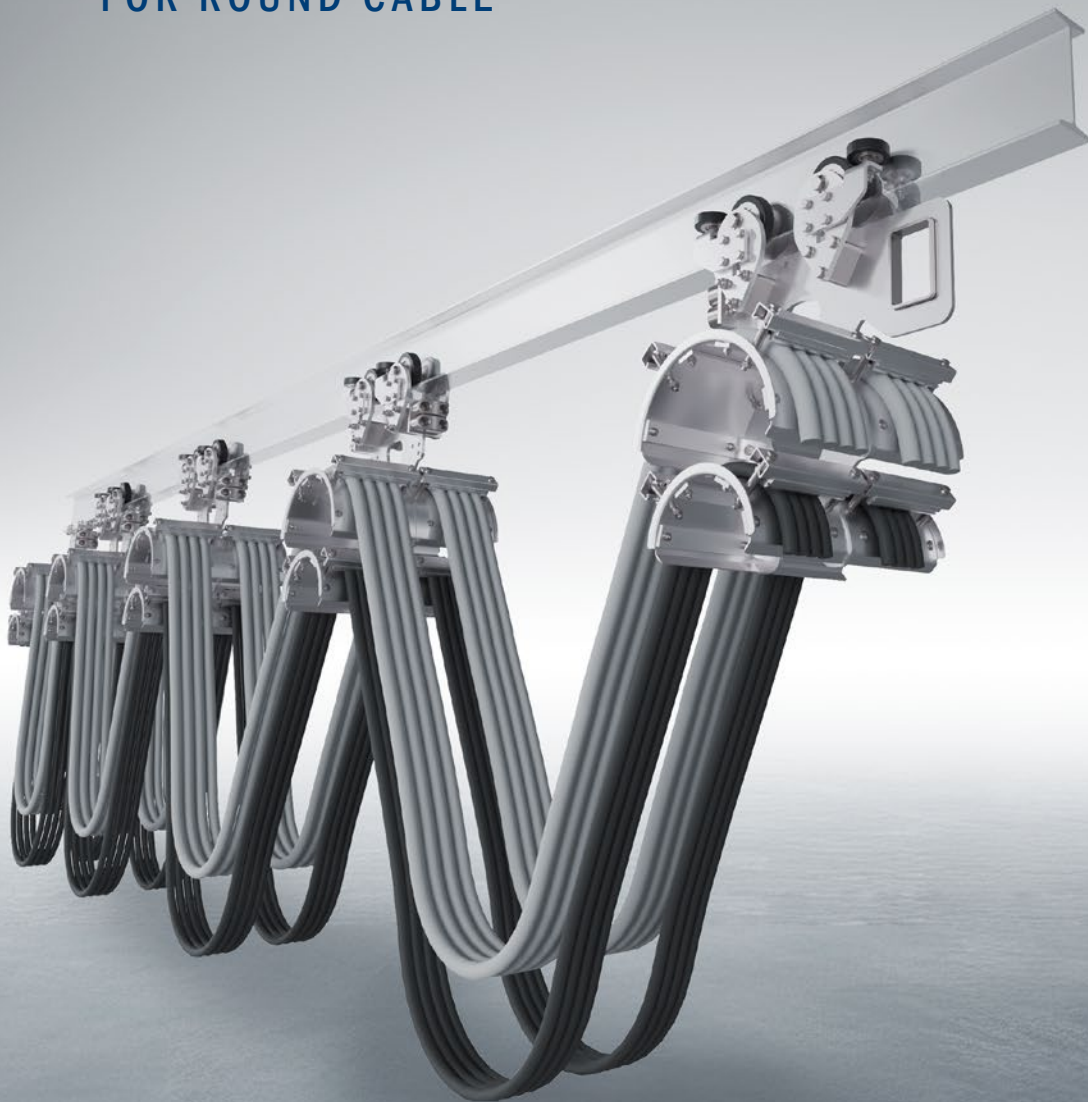



FESTOON SYSTEMS I-BEAM SUPPORTED

FOR ROUND CABLE



VAHLE FESTOON SYSTEMS

Contents	Page		Page
General Information	2	Spare Parts	18
Questionnaire	3	Typical Application and How to Order	19
Cable Carriers for Round Cable 	4-13	Installation Information	20
Cable Saddles for Round Cable 	14-15	How to determine: Storage Distance, Cable Length, Number of Carriers	21
Cable Loop Clamps for Round Cable 	16	Cable Loop Graphs	22-24
Tow Rope Assemblies	17	Application photos	21, 25

General

VAHLE Festoon systems support electric cables or hoses for mobile machinery.

The cable carriers contained in this catalog comply with VDE regulations and international safety requirements. Round cables and fittings per our catalog no. 8L.

Track profiles can be standard I-beams or flat flange beam sizes, some of which are shown in this catalog, however, actual dimensions of beams being utilized for track purposes should be specified with enquiries and orders.

Application

Cable carrier ride on an I-beam parallel to the traversing track of the equipment. This arrangement ensures that the total length of the machine (i. e. hoist, bridge trolley, etc.) is used as storage space. Where there is sufficient space for the storage distance, the cable carriers can also run on the hoist track.

All models have a lead clamp attached to an outrigger of the machinery.

The track clamp is the stationary fastening point of the cables and is bolted to the I-beam track at fixed position. The cable ends extending from the track clamp are terminated at a

junction box. The track clamp, together with the bumper, facing towards the last carrier, serves as a limit stop for the carriers. Tow ropes are optional depending on the cable arrangement, loop depth, speed, and acceleration. The strain relief ropes are slightly shorter than the electric cables in each loop.

Cable loop clamps are available and keep the cables together when the system is in operation.

Layout

When selecting a Festoon System please refer to page 21 in this catalog.

Layout considerations for cable carriers are cable dimensions, storage space available, maximum loop depth allowable, over-all height and width which the system will occupy, I-beam selection, and maximum speed of travel.

After the type of carrier and the loop depth have been determined, please refer to the graphs on pages 22-24 for the number of loops required.

In case you desire a detailed quotation on VAHLE Festoon Systems please do not hesitate to contact our nearest local representative or mail the completed questionnaire on page 3 of this catalog.

Our cable carrier programm:

Catalog No. 8a: Cable Carriers on □-Tracks

Catalog No. 8b: Cable Carriers for flatform cable on I-Beam Tracks

Catalog No. 8c: Cable Carriers for round cable on I-Beam Tracks

Catalog No. 8d: Cable Carriers on ◇-Tracks

Catalog No. 8e: Conductor cables & Fittings

QUESTIONNAIRE

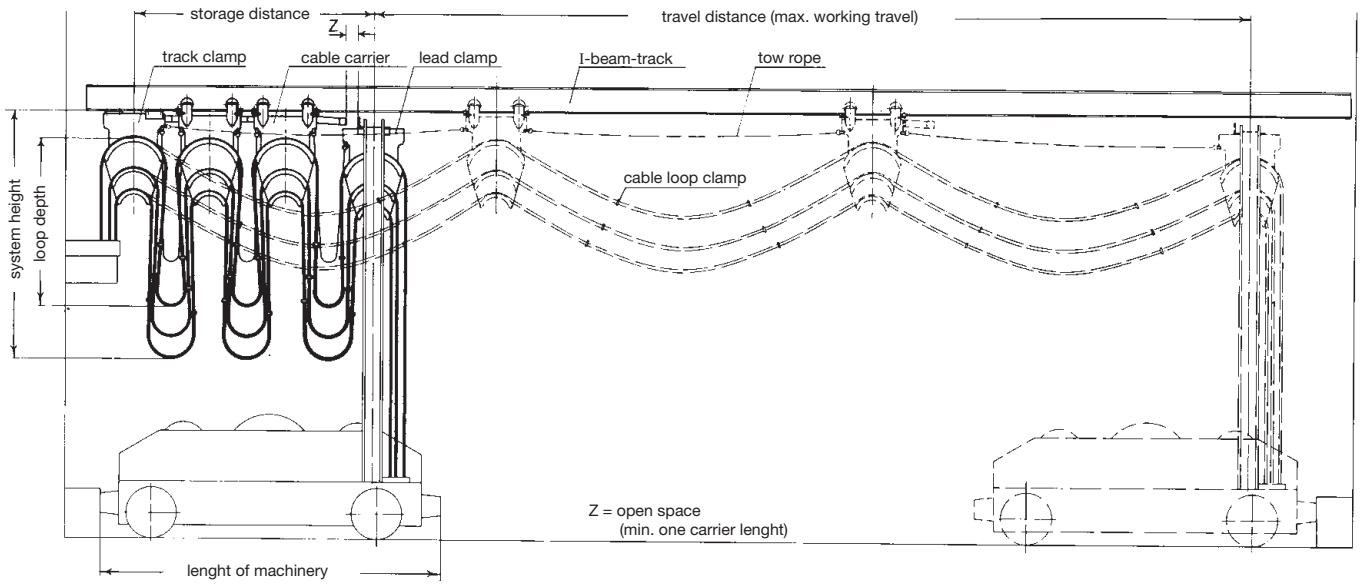

Name and address of customer: _____

Ref.: _____

1. Type of application _____
2. Outdoor Indoor _____
3. Temperature conditions _____ °C min. _____ °C max. _____
4. Is round- or flatform cable required? _____
5. What is the max. storage distance? _____
6. Is it possible to extend the track for the festoon cable system in case the length of crane trolley is insufficient for storage?
 yes, by _____ mm, no, not possible
7. Special operating/environmental conditions: _____

8. Length of crane trolley: _____ mm
9. Travel distance of crane trolley: _____ mm
10. Travelling speed: _____ m/min.
11. Acceleration: _____ m/sec²
12. max. loop depth: _____ mm
13. Hook up cable length (both ends): _____ mm
14. Type of I-beam track: INP IPE

Required cables

Quantity of Cables.	Number of cores cross section	Ø mm	width x strenght with flat cables

CABLE CARRIERS W 25 R, W 26 R, W 30 R

Normal- and europe profile



Engineering data

Type	W 25 R (2 wheels)	W 26 R (3 wheels)	W 30 R (4 wheels)
Carrying capacity	10 kg	10 kg	20 kg
Wheels	K	Flanged polyamid wheels Ø 45/60 mm on stainless steel bushed bearings	
	KL	Flanged polyamid wheels Ø 45/60 mm on sealed (2 RS) precision ball bearings	
Material	Polyamid carrierbody adjustable on light metal profile. Cable support saddles: polyamid Hardware: galvanized		
Temperature range	- 30° C to + 100° C		
Travelling speed	max. 60 m/min		

(for calculation of storage distance)

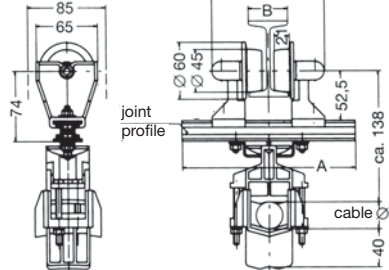

Cable carrier for round cable and hoses

Type W 25 R (2 wheels)

Type	Wheels	Cable ø mm	A mm	for Track-Profile		Weight kg	Order-No.
				INP	IPE		
W 25 R/65 K -1	K	5 mm to 38 mm	185	80-220	80-200	0,550	346 665
W 25 R/65 K -2			235	240-380	220-300	0,580	346 666
W 25 R/65 KL-1	KL		185	80-220	80-200	0,630	346 667
W 25 R/65 KL-2			235	240-380	220-300	0,660	346 668

(for calculation of storage distance)

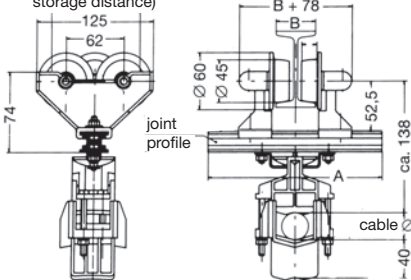

Cable carrier for round cable and hoses

Type W 26 R (3 wheels)

Type	Wheels	Cable ø mm	A mm	for Track-Profile		Weight kg	Order-No.
				INP	IPE		
W 26 R/125 K -1	K	5 mm to 38 mm	185	80-220	80-200	0,620	346 669
W 26 R/125 K -2			235	240-380	220-300	0,650	346 670
W 26 R/125 KL-1	KL		185	80-220	80-200	0,740	346 671
W 26 R/125 KL-2			235	240-380	220-300	0,770	346 672

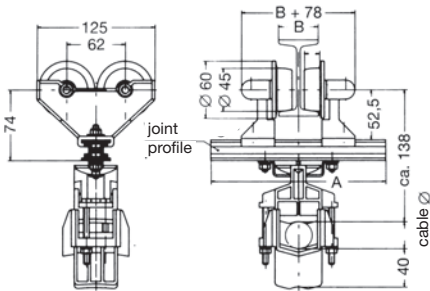

Cable carrier for round cable and hoses

Type W 30 R (4 wheels)

Type	Wheels	Cable ø mm	A mm	for Track-Profile		Weight kg	Order-No.
				INP	IPE		
W 30 R/125 K -1	K	5 mm to 38 mm	185	80-220	80-200	0,690	346 673
W 30 R/125 K -2			235	240-380	220-300	0,720	346 674
W 30 R/125 KL-1	KL		185	80-220	80-200	0,850	346 675
W 30 R/125 KL-2			235	240-380	220-300	0,880	346 676

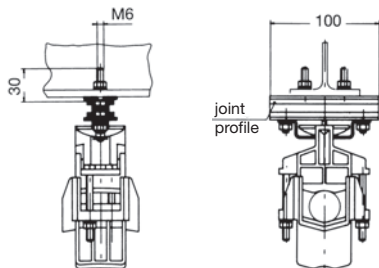

Lead carrier and Track clamp for round cable and hoses

Type	for cable carrier	Weight kg	Order-No.
E 25-30 R	W 25 R/ 65 ...	0,310	346 677
	W 26 R/125 ...		
	W 30 R/125 ...		

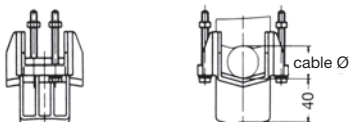

Support saddles for round cable and hoses for additional tiers

Type	for cable carrier	Weight kg	Order-No.
LAR	all Types	0,110	312 500



CABLE CARRIERS W 45 FR

Engineering data

Type	W 45 FR on I-profil for flatform and round cable
Carrying capacity	50 kg (max. 80 kg - consult factory)
Travel speed	max. 120 m/min. when using appropriate cable tension relief
Wheel sets	for standard tracks INP 80 to INP 200 and for flat flange beams IPE 80 to IPE 200 other profiles on request on stainless steel bushed bearing
Wheels	flanged steel wheels \varnothing 45/60 mm, hardened and galvanized, steel kick-up rollers \varnothing 32 mm with bushed bearing and tread hardened and galvanized
Material	Carrier body: steel galvanized Support saddle: aluminium
Operating ambients	-30 °C to +100 °C

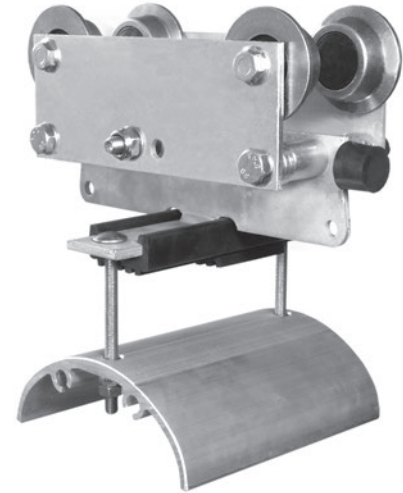

Cable carrier W 45 FR

Type	max. clamping capacity mm height x width (s x k)	L mm	B mm	D mm	Weight kg	Order-no. w/o kick-up rollers	Order-no. w/kick-up rollers
W 45 FR/160- 80 B 175	35 x 135	160	175	80	2,750	348 663	348 685
W 45 FR/160- 80 B 225	35 x 185	160	225	80	2,880	348 664	348 686
W 45 FR/160-100 B 175	25 x 135	160	175	100	2,830	348 665	348 687
W 45 FR/160-100 B 225	25 x 185	160	225	100	3,000	348 666	348 688
W 45 FR/200- 80 B 175	55 x 135	200	175	80	3,050	348 667	348 689
W 45 FR/200- 80 B 225	55 x 185	200	225	80	3,180	348 668	348 690
W 45 FR/200-100 B 175	45 x 135	200	175	100	3,130	348 669	348 691
W 45 FR/200-100 B 225	45 x 185	200	225	100	3,300	348 670	348 692
W 45 FR/200-140 B 175	25 x 135	200	175	140	3,370	348 671	348 693
W 45 FR/200-140 B 225	25 x 185	200	225	140	3,610	348 672	348 694
W 45 FR/250-100 B 175	70 x 135	250	175	100	3,490	348 673	348 695
W 45 FR/250-100 B 225	70 x 185	250	225	100	3,660	348 674	348 696
W 45 FR/250-140 B 175	50 x 135	250	175	140	3,730	348 675	348 697
W 45 FR/250-140 B 225	50 x 185	250	225	140	3,970	348 676	348 698
W 45 FR/250-170 B 175	35 x 135	250	175	170	3,790	348 677	348 699
W 45 FR/250-170 B 225	35 x 185	250	225	170	4,040	348 678	348 700
W 45 FR/290-140 B 175	70 x 135	290	175	140	4,010	348 679	348 701
W 45 FR/290-140 B 225	70 x 185	290	225	140	4,250	348 680	348 702
W 45 FR/290-170 B 175	55 x 135	290	175	170	4,070	348 681	348 703
W 45 FR/290-170 B 225	55 x 185	290	225	170	4,230	348 682	348 704
W 45 FR/325-170 B 175	72 x 135	325	175	170	4,290	348 683	348 705
W 45 FR/325-170 B 225	72 x 185	325	225	170	4,540	348 684	348 706

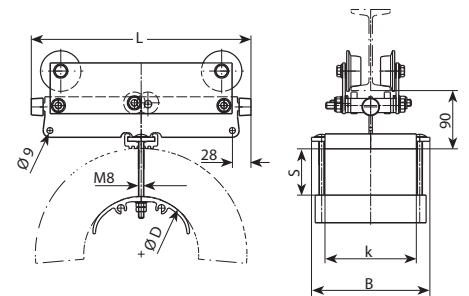

Collecting clamp for round cables
Extension rubber profile can be ordered per meter (Order-no.: 348 845)

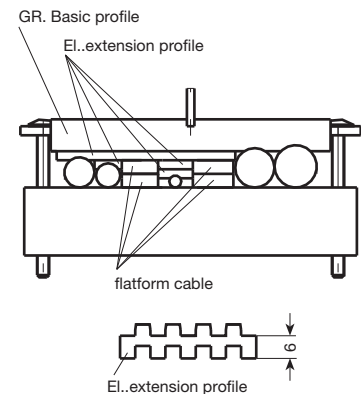



Lead clamp MW 45

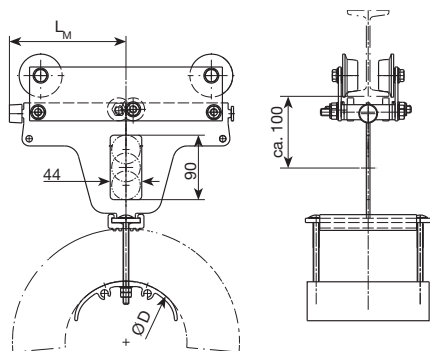

Type	for Cable carrier	L _M mm	D mm	Weight kg	Order-No.
MW 45 FR/200- 80 B 175	W 45 FR/160- 80 B 175 W 45 FR/200- 80 B 175	100	80	3,290	348 741
MW 45 FR/200- 80 B 225	W 45 FR/160- 80 B 225 W 45 FR/200- 80 B 225	100	80	3,430	348 742
MW 45 FR/200-100 B 175	W 45 FR/160-100 B 175 W 45 FR/200-100 B 175	100	100	3,370	348 743
MW 45 FR/200-100 B 225	W 45 FR/160- 100 B 225 W 45 FR/200- 100 B 225	100	100	3,550	348 744
MW 45 FR/200-140 B 175	W 45 FR/200-140 B 175	100	140	3,610	348 745
MW 45 FR/200-140 B 225	W 45 FR/200-140 B 225	100	140	3,860	348 746
MW 45 FR/325-100 B 175	W 45 FR/250-100 B 175	162	100	4,280	348 747
MW 45 FR/325-100 B 225	W 45 FR/250-100 B 225	162	100	4,450	348 748
MW 45 FR/325-140 B 175	W 45 FR/250-140 B 175 W 45 FR/290-140 B 175	162	140	4,510	348 749
MW 45 FR/325-140 B 225	W 45 FR/250-140 B 225 W 45 FR/290-140 B 225	162	140	4,760	348 750
MW 45 FR/325-170 B 175	W 45 FR/250-170 B 175 W 45 FR/290-170 B 175 W 45 FR/325-170 B 175	162	170	4,570	348 751
MW 45 FR/325-170 B 225	W 45 FR/250-170 B 225 W 45 FR/290-170 B 225 W 45 FR/325-170 B 225	162	170	4,830	348 752

Track clamp E 45

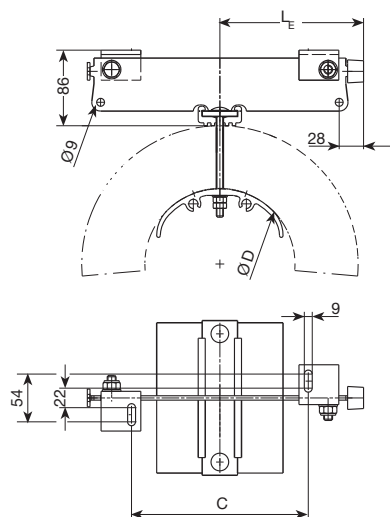

Type	for Cable carrier	L _E mm	D mm	C mm	Weight kg	Order-No.
E 45 FR/160- 80 B 175	W 45 FR/160- 80 B 175	80	80	35	1,120	348 786
E 45 FR/160- 80 B 225	W 45 FR/160- 80 B 225	80	80	35	1,250	348 787
E 45 FR/160-100 B 175	W 45 FR/160-100 B 175	80	100	35	1,200	348 788
E 45 FR/160-100 B 225	W 45 FR/160-100 B 225	80	100	35	1,370	348 789
E 45 FR/200- 80 B 175	W 45 FR/200- 80 B 175	100	80	75	1,220	348 790
E 45 FR/200- 80 B 225	W 45 FR/200- 80 B 225	100	80	75	1,350	348 791
E 45 FR/200-100 B 175	W 45 FR/200-100 B 175	100	100	75	1,300	348 792
E 45 FR/200-100 B 225	W 45 FR/200-100 B 225	100	100	75	1,470	348 793
E 45 FR/200-140 B 175	W 45 FR/200-140 B 175	100	140	75	1,540	348 794
E 45 FR/200-140 B 225	W 45 FR/200-140 B 225	100	140	75	1,780	348 795
E 45 FR/250-100 B 175	W 45 FR/250-100 B 175	125	100	125	1,420	348 796
E 45 FR/250-100 B 225	W 45 FR/250-100 B 225	125	100	125	1,590	348 797
E 45 FR/250-140 B 175	W 45 FR/250-140 B 175	125	140	125	1,660	348 798
E 45 FR/250-140 B 225	W 45 FR/250-140 B 225	125	140	125	1,900	348 799
E 45 FR/250-170 B 175	W 45 FR/250-170 B 175	125	170	125	1,720	348 800
E 45 FR/250-170 B 225	W 45 FR/250-170 B 225	125	170	125	1,970	348 801
E 45 FR/290-140 B 175	W 45 FR/290-140 B 175	145	140	165	1,760	348 802
E 45 FR/290-140 B 225	W 45 FR/290-140 B 225	145	140	165	2,000	348 803
E 45 FR/290-170 B 175	W 45 FR/290-170 B 175	145	170	165	1,820	348 804
E 45 FR/290-170 B 225	W 45 FR/290-170 B 225	145	170	165	2,070	348 805
E 45 FR/325-170 B 175	W 45 FR/325-170 B 175	162	170	200	1,900	348 806
E 45 FR/325-170 B 225	W 45 FR/325-170 B 225	162	170	200	2,150	348 807



CABLE CARRIERS W 110

Normal- and europe profile

Engineering data

Type	WE 110 R ... (S) for beam -I PE 80 – 200 WN 110 R ... (S) for beam -I NP 80 – 220
Carrying capacity	30 kg
Wheels	a) Flanged polyamid wheels on stainless steel bushed bearings b) Steel wheels hardened and galvanized with sealed ball bearings
Material	carrierbody: light metal - seawater resistant support saddles: polyamid hardware: galvanized
Temperature resistance for all materials	-30° C to +100° C
Travelling speed	max. 80 m/min

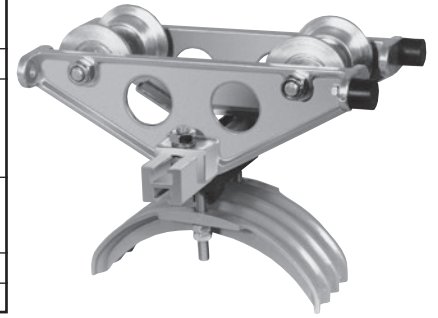

Cable carrier for round cable

Type ⁽¹⁾		wheels	max. cable Ø mm	B	C	D	Weight kg	Order-No.	Order-No. with bumper
Cable carrier standard beam	WN 110 R/200	a	3 x Ø 20	71	65	200	1,360	345 920	345 923
Cable carrier Fl. fl. beam	WE 110 R/200	a	3 x Ø 20	71	65	200	1,360	345 921	345 924
Cable carrier standard and Fl. fl. beam	W 110 R/200 S	b	3 x Ø 20	71	65	200	2,130	345 922	345 925

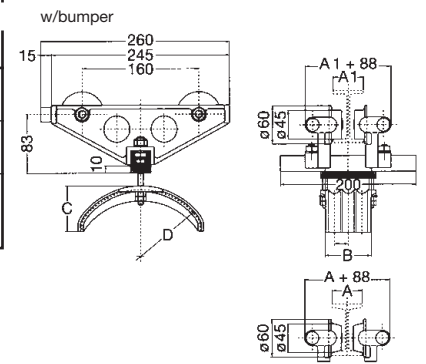

Standard beam

Beam TNP	80	100	120	140	160	180	200	220
Dim. A	42	50	58	66	74	82	90	98

Flat flange beam

Beam IPE	80	100	120	140	160	180	200
Dim. A 1	46	55	64	73	82	91	100

Lead clamp for round cable

Type	for cable carrier	B	C	D	Weight kg	Order-No.	
Lead clamp	M 110 R/200	W (N, E) 110 R/200 (S)	71	65	200	1,170	345 926

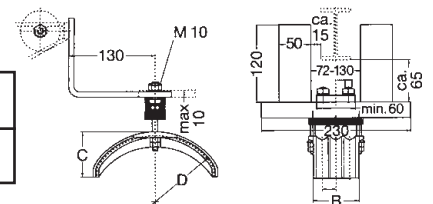

Track clamp for round cable and bumper

Type	for cable carrier	B	C	D	Weight kg	Order-No.	
Track clamp	E 110 R/200⁽²⁾	W (N, E) 110 R/200 (S)	71	65	200	0,450	345 927
Bumper	PS 3-4	-	-	-	0,410	340 100	

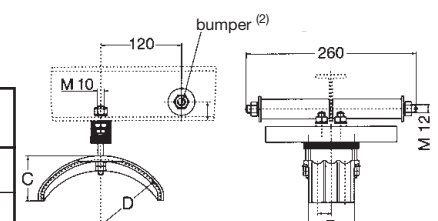

⁽¹⁾ Use suffix-P for bumper version (example: W 110 R/200 S-P)

⁽²⁾ Bumper PS 3-4 to be ordered separately.

CABLE CARRIERS W 120 • HEAVY DUTY

Normal- and europe profile



Engineering data

Type	WN 120 R/260 for beam $\overline{\text{INP}}$ 100 – 160 WE 120 R/260 for beam $\overline{\text{IPE}}$ 100 – 160
Carrying capacity	350 kg
Wheels	steel wheels hardened and galvanized with sealed precision ball bearings; flanged steel guide rollers hardened and galvanized with sealed ball bearings for WE-series only
Guide rollers	(only at WE-type) roller with ball bearing, made of steel, hardened, galvanically zinc-plated;
Material	carrier body: steel galvanized support saddles: polyamid temperature resistance for all materials: $-30^{\circ}\text{C} - +100^{\circ}\text{C}$
Travelling speed	max. 120 m/min (525 ft/min) when using proper cable tension relief tow ropes

Cable carrier

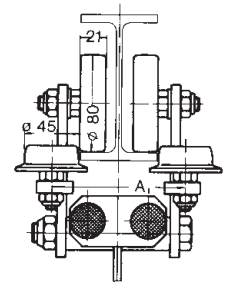
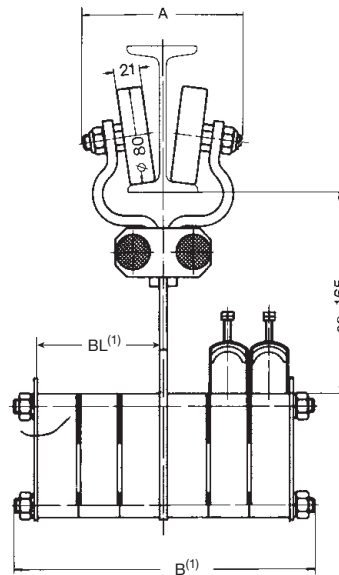
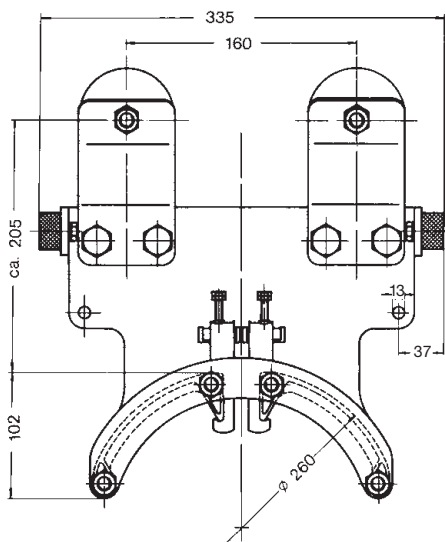

Lead clamp

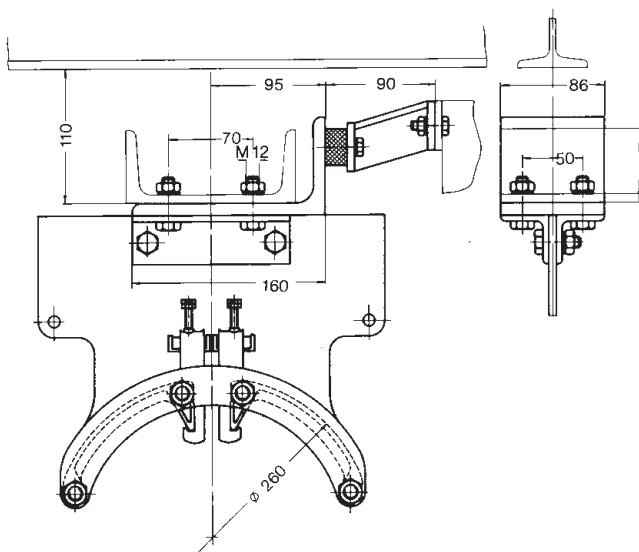

Track clamp

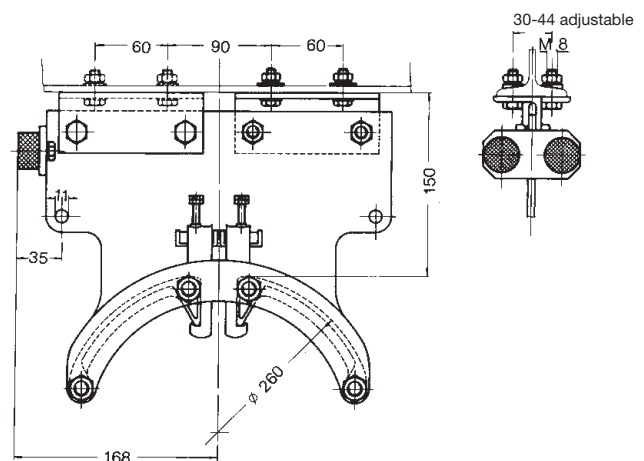



CABLE CARRIERS W 120 • HEAVY DUTY

Normal- and europe profile

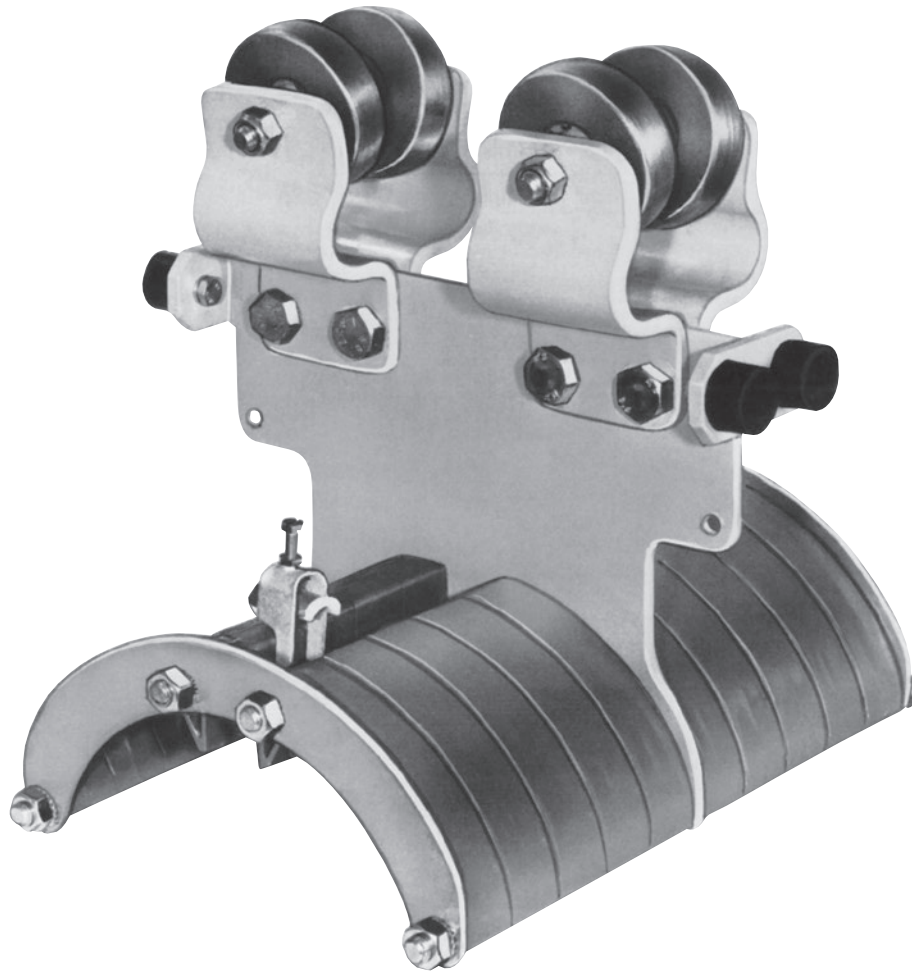

Standard beam

I NP	100	120	140	160
Dim A mm	130	130	130	130

Flat flange beam

I PE	100	120	140	160
Dim. A ₁ mm	103	112	121	130

Standard beam

Type		Number of tiers	max. cable ø mm	Weight kg	Order-No.
Cable carrier	WN 120 R/260	1	26	10,100	341 410
Lead carrier ⁽¹⁾	M 120 R/260	1	26	6,300	341 420
Track clamp	E 120 R/260	1	26	3,800	341 430

Europe profile

Type		Number of tiers	max. cable ø mm	Weight kg	Order-No.
LCable carrier	WE 120 R/260	1	26	11,200	341 440
Lead carrier ⁽¹⁾	M 120 R/260	1	26	6,300	341 420
Track clamp	E 120 R/260	1	26	3,800	341 430

⁽¹⁾ incl.bumper extension.

CABLE CARRIERS W 130 • HEAVY DUTY

Normal- and europe profile



Engineering data

Type	WN 130 R/360 for I NP 140-200 WN 130 R/360/260 for I NP 140-200 WE 130 R/360 for I PE 140-200 WE 130 R/360/260 for I PE 140-200
Carrying capacity	550 kg
Wheels	steel wheels hardened and galvanized with sealed precision ball bearings; guide rollers hardened and galvanized with sealed ball bearings
Guide and support rollers	Cylindrical running rollers with ball bearing, made of steel, running surface hardened, galvanically zinc-plated
Material	carrierbody: steel galvanized support saddles: polyamid temperature resistance for all materials: -30° C to +100° C
Travelling speed	max. 120 m/min (525 ft/min) when using proper cable tension relief tow ropes

Cable carrier

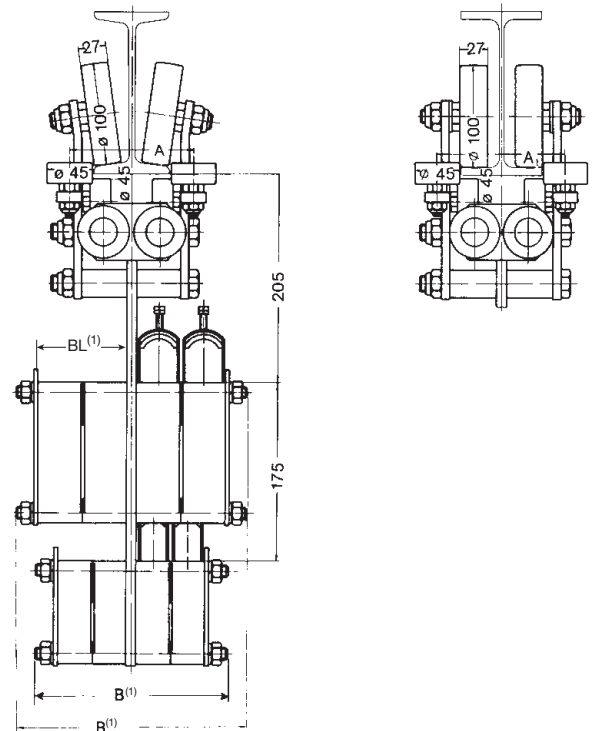
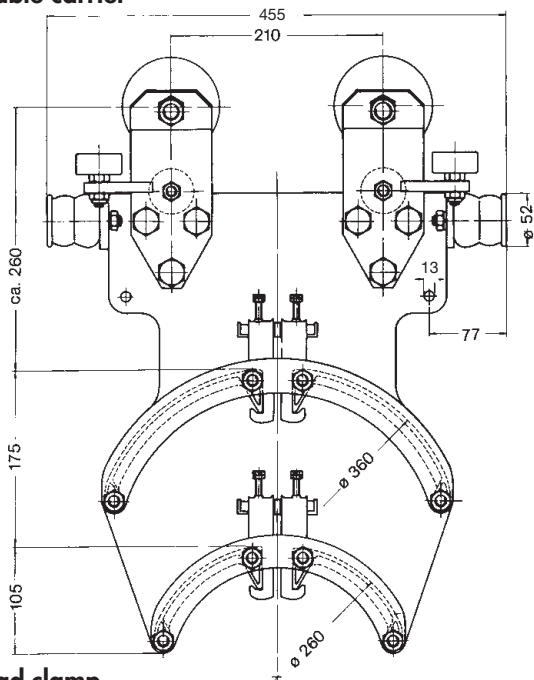

Lead clamp

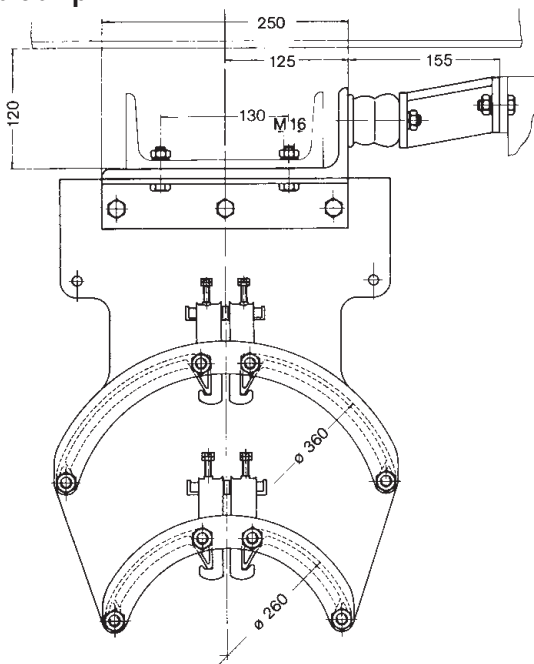

Track clamp

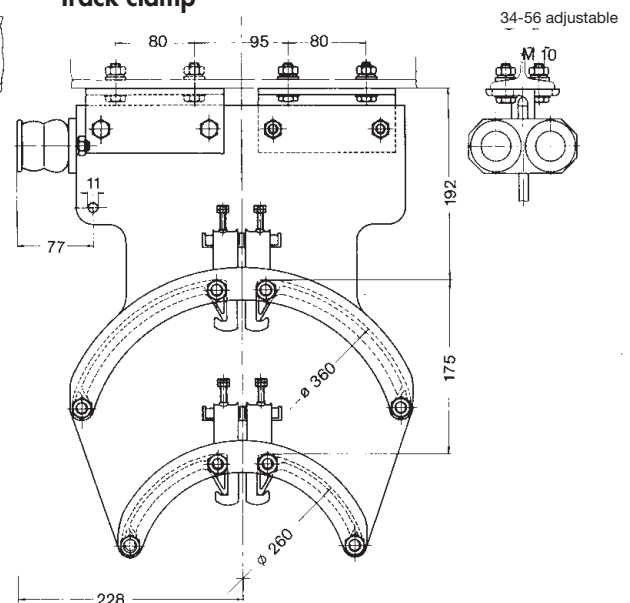

(1) see page 14 and 15 for dim. B and BL

Wheel set arrangements for profiles with differing flange dimensions on request.



CABLE CARRIERS W 130 • HEAVY DUTY

Normal- and europe profile

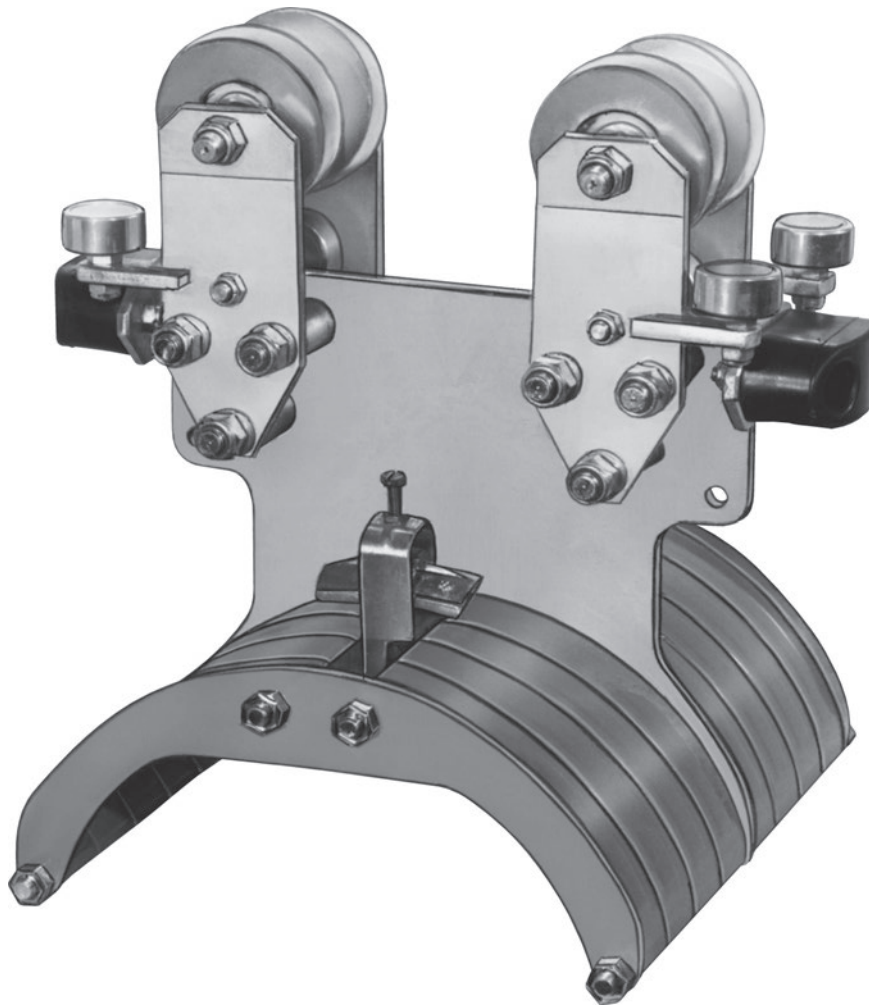

Standard beam

I NP	140	160	180	200
Dim. A mm	114	122	130	138

Flat flange beam

I PE	140	160	180	200
Dim. A ₁ mm	121	130	139	148

Standard beam

Type		Number of tiers	max. cable Ø mm	Weight kg	Order-No.
Cable carrier	WN 130 R/360	1	36	21,700	341 470
	WN 130 R/360/260	2	36	25,200	341 480
Lead clamp including bumper extension	M 130 R/360	1	36	12,500	341 490
	M 130 R/360/260	2	36	16,000	341 500
Track clamp	E 130 R/360	1	36	8,000	341 510
	E 130 R/360/260	2	36	11,500	341 520

Flat flange beam

Type		Number of tiers	max. cable Ø mm	Weight kg	Order-No.
Cable carrier	WE 130 R/360	1	36	21,700	341 530
	WE 130 R/360/260	2	36	25,200	341 540
Lead clamp including bumper extension	M 130 R/360	1	36	12,500	341 490
	M 130 R/360/260	2	36	16,000	341 500
Track clamp	E 130 R/360	1	36	8,000	341 510
	E 130 R/360/260	2	36	11,500	341 520

CABLE CARRIERS W 140 • HEAVY DUTY

Normal- and europe profile



Engineering data

Type	WN 140 R/490 for INP 140-200 WN 140 R/490/360 for INP 140-200 WN 140 R/490/360/260 for INP 140-200 WE 140 R/490 for IPE 140-200 WE 140 R/490/360 for IPE 140-200 WE 140 R/490/360/260 for IPE 140-200
Carrying capacity	550 kg
Wheels	steel wheels hardened and galvanized with sealed precision ball bearings; guide rollers hardened and galvanized with sealed ball bearings
Guide and support rollers	Cylindrical running rollers with ball bearing, made of steel, running surface hardened, galvanically zinc-plated;
Material	carrierbody: steel galvanized; support saddles: polyamid temperature resistance for all materials: -30° C – +100° C
Travelling speed	max. 120 m/min (525 ft/min) when using proper cable tension relief tow ropes

Cable carrier

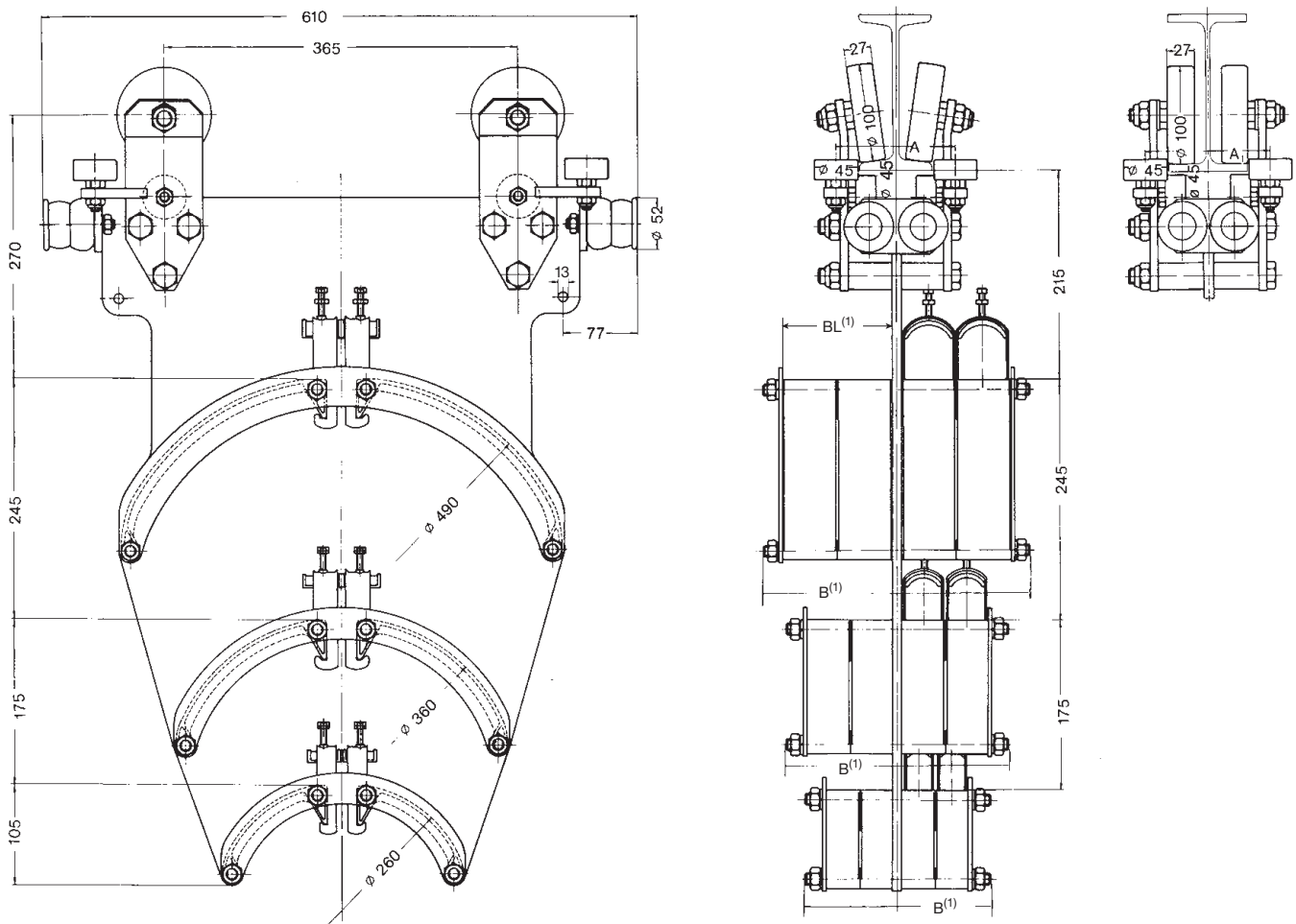

⁽¹⁾ see page 14 and 15 for dim. B and BL

Wheel set arrangements for profiles with differing flange dimensions on request.



CABLE CARRIERS W 140 • HEAVY DUTY

Normal- and europe profile

Lead clamp

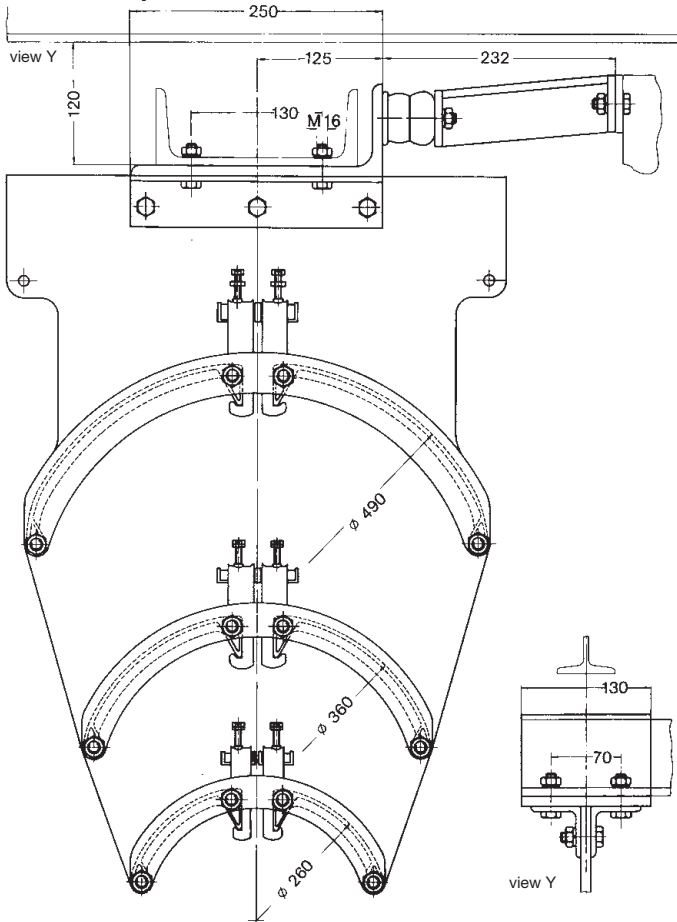

Track clamp

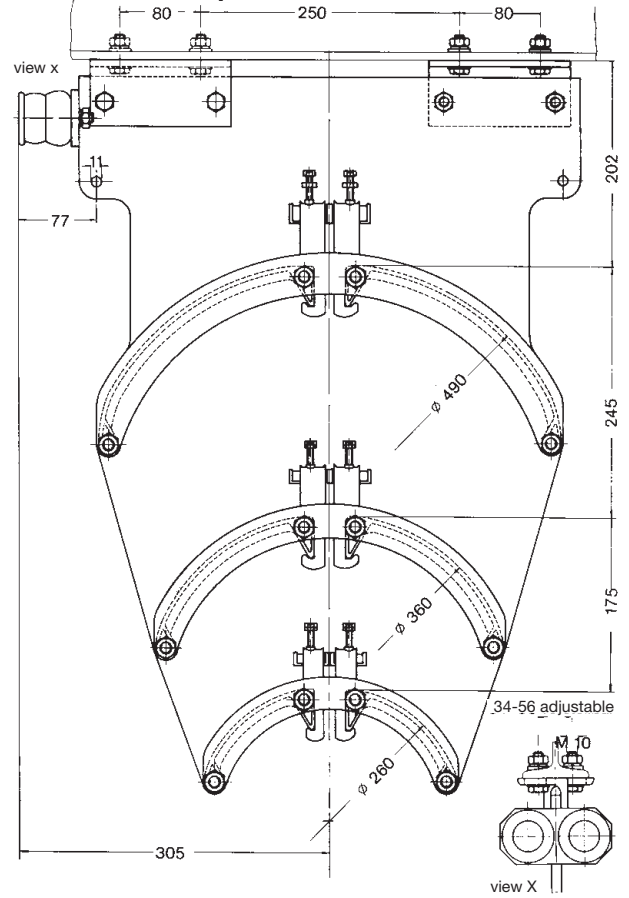

Standard beam

INP	140	160	180	200
Dim. A mm	114	122	130	138

Flat flange beam

IPE	140	160	180	200
Dim. A ₁ mm	121	130	139	148

Normalprofil

Type		Number of tiers	max. cable Ø mm	Weight kg	Order-No.
Cable carrier	WN 140 R/490	1	49	25,700	341 590
	WN 140 R/490/360	2	49	34,200	341 600
	WN 140 R/490/360/260	3	49	38,200	341 610
Lead clamp including bumper extension	M 140 R/490	1	49	16,800	341 620
	M 140 R/490/360	2	49	25,300	341 630
	M 140 R/490/360/260	3	49	29,300	341 640
Track clamp	E 140 R/490	1	49	12,000	341 650
	E 140 R/490/360	2	49	20,500	341 660
	E 140 R/490/360/260	3	49	24,500	341 670

Flat flange beam

Cable carrier	WE 140 R/490	1	49	25,700	341 680
	WE 140 R/490/360	2	49	34,200	341 690
	WE 140 R/490/360/260	3	49	38,200	341 700
Lead clamp including bumper extension	M 140 R/490	1	49	16,800	341 620
	M 140 R/490/360	2	49	25,300	341 630
	M 140 R/490/360/260	3	49	29,300	341 640
Track clamp	E 140 R/490	1	49	12,000	341 650
	E 140 R/490/360	2	49	20,500	341 660
	E 140 R/490/360/260	3	49	24,500	341 670



CABLE SUPPORT SADDLES

Cable arrangement		type of support saddle	Order-No.	type of support saddle	Order-No.	dimension B ⁽¹⁾ mm	Weight kg
○ = Ø 10–26 mm ⊙ = Ø 27–36 mm ● = Ø 37–49 mm		LA 490/ 2	342 100	LK 490/ 2	342 980	162	1,810
		LA 490/ 4	342 110	LK 490/ 4	342 990	274	2,910
		LA 490/ 6	342 120	LK 490/ 6	343 000	386	4,010
		LA 490/ 8	342 130	LK 490/ 8	343 010	498	5,110
		LA 490/ 10	342 140	LK 490/ 10	343 020	610	6,210
		LA 490/ 202	342 150	LK 490/ 202	343 030	274	2,690
		LA 490/ 204	342 160	LK 490/ 204	343 040	386	3,570
		LA 490/ 206	342 170	LK 490/ 206	343 050	386	3,770
		LA 490/ 208	342 180	LK 490/ 208	343 060	498	4,650
		LA 490/ 2010	342 190	LK 490/ 2010	343 070	498	4,850
		LA 490/ 2012	342 200	LK 490/ 2012	343 080	610	5,730
		LA 490/ 402	342 210	LK 490/ 402	343 090	386	3,790
		LA 490/ 404	342 220	LK 490/ 404	343 100	498	4,670
		LA 490/ 406	342 230	LK 490/ 406	343 110	498	4,870
		LA 490/ 408	342 240	LK 490/ 408	343 120	610	5,750
	LA 490/ 4010	342 250	LK 490/ 4010	343 130	610	5,950	
Ø of support saddle 490 mm		LA 490/ 602	342 260	LK 490/ 602	343 140	498	4,890
		LA 490/ 604	342 270	LK 490/ 604	343 150	610	5,770
		LA 490/ 606	342 280	LK 490/ 606	343 160	610	5,970
		LA 490/ 802	342 290	LK 490/ 802	343 170	610	5,990
		LA 490/ 804	342 300	LK 490/ 804	343 180	610	6,190
		LA 490/ 22	342 310	LK 490/ 22	343 190	274	2,770
		LA 490/ 24	342 320	LK 490/ 24	343 200	386	3,730
		LA 490/ 26	342 330	LK 490/ 26	343 210	498	4,690
		LA 490/ 28	342 340	LK 490/ 28	343 220	498	4,970
		LA 490/ 210	342 350	LK 490/ 210	343 230	610	5,930
		LA 490/ 42	342 360	LK 490/ 42	343 240	386	3,970
		LA 490/ 44	342 370	LK 490/ 44	343 250	498	4,930
		LA 490/ 46	342 380	LK 490/ 46	343 260	610	5,890
		LA 490/ 48	342 390	LK 490/ 48	343 270	610	6,170
		LA 490/ 62	342 400	LK 490/ 62	343 280	498	4,970
	LA 490/ 64	342 410	LK 490/ 64	343 290	610	5,930	
	LA 490/ 82	342 420	LK 490/ 82	343 300	610	6,070	
	LA 490/ 222	342 430	LK 490/ 222	343 310	386	3,650	
	LA 490/ 224	342 440	LK 490/ 224	343 320	386	3,850	
	LA 490/ 226	342 450	LK 490/ 226	343 330	498	4,730	
	LA 490/ 228	342 460	LK 490/ 228	343 340	610	5,610	
	LA 490/ 2210	342 470	LK 490/ 2210	343 350	610	5,810	
	LA 490/ 242	342 480	LK 490/ 242	343 360	386	3,930	
	LA 490/ 244	342 490	LK 490/ 244	343 370	498	4,810	
	LA 490/ 246	342 500	LK 490/ 246	343 380	610	5,690	
	LA 490/ 248	342 510	LK 490/ 248	343 390	610	5,890	
	LA 490/ 262	342 520	LK 490/ 262	343 400	498	4,890	
	LA 490/ 264	342 530	LK 490/ 264	343 410	610	5,770	
	LA 490/ 266	342 540	LK 490/ 266	343 420	610	5,970	
	LA 490/ 282	342 550	LK 490/ 282	343 430	610	5,850	
	LA 490/ 422	342 560	LK 490/ 422	343 440	498	4,850	
	LA 490/ 424	342 570	LK 490/ 424	343 450	498	5,050	
	LA 490/ 426	342 580	LK 490/ 426	343 460	610	5,930	
	LA 490/ 428	342 590	LK 490/ 428	343 470	610	6,130	
	LA 490/ 442	342 600	LK 490/ 442	343 480	498	5,130	
	LA 490/ 444	342 610	LK 490/ 444	343 490	610	6,010	
	LA 490/ 462	342 620	LK 490/ 462	343 500	610	6,090	
	LA 490/ 622	342 630	LK 490/ 622	343 510	610	5,850	
	LA 490/ 624	342 640	LK 490/ 624	343 520	610	6,050	

Maximal usable support saddle⁽²⁾ per side in mm =
$$BL \frac{B - 50 \text{ mm}}{2}$$

⁽¹⁾ Dimension B = max. width of support saddles, see pages 8-13.

⁽²⁾ Dimension BL see pages 8-13.



CABLE LOOP CLAMPS

Material:

Light metal, seawater resistant

Clamping insert made of rubber

Spacer made of PVC

Screws and accessories made of steel, galvanized⁽¹⁾

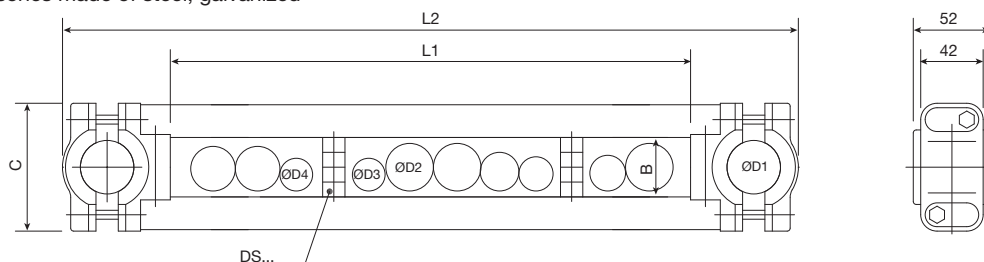

Cable loop clamp									
Type	B	C	D1	D2	D3 + D4 ⁽²⁾	L1	L2	Weight kg	Order-No.
mm									
LS26 - 100						100	max. 234	0,71	347 100
LS26 - 150						150	max. 284	0,77	347 101
LS26 - 200						200	max.334	0,82	347 102
LS26 - 250						250	max.384	0,88	347 103
LS26 - 300						300	max.434	0,94	347 104
LS26 - 350	30	75	14 - 26	max. 26	34	350	max.484	0,99	347 105
LS26 - 400						400	max.534	1,05	347 106
LS26 - 450						450	max.584	1,10	347 107
LS26 - 500						500	max.634	1,16	347 108
LS26 - 550						550	max.684	1,21	347 109
LS26 - 600						600	max.734	1,27	347 110
LS36 - 100						100	max.245	0,78	347 111
LS36 - 150						150	max.295	0,84	347 112
LS36 - 200						200	max.345	0,89	347 113
LS36 - 250						250	max.395	0,95	347 114
LS36 - 300						300	max.445	1,01	347 115
LS36 - 350	40	86	24 - 36	max. 46	46	350	max.495	1,08	347 116
LS36 - 400						400	max.545	1,12	347 117
LS36 - 450						450	max.595	1,17	347 118
LS36 - 500						500	max.645	1,23	347 119
LS36 - 550						550	max.695	1,28	347 120
LS36 - 600						600	max.745	1,34	347 121
LS46 - 100						100	max.260	0,86	347 122
LS46 - 150						150	max.310	0,92	347 123
LS46 - 200						200	max.360	0,97	347 124
LS46 - 250						250	max.410	1,03	347 125
LS46 - 300						300	max.460	1,09	347 126
LS46 - 350	50	96	30 - 46	max. 48	56	350	max.510	1,14	347 127
LS46 - 400						400	max.560	1,20	347 128
LS46 - 450						450	max.610	1,25	347 129
LS46 - 500						500	max.660	1,31	347 130
LS46 - 550						550	max.710	1,36	347 131
LS46 - 600						600	max.760	1,42	347 132

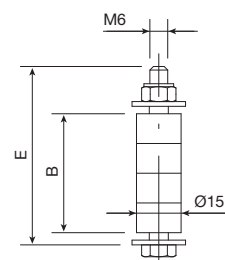

Spacer				
⁽²⁾ If the amount of cables side by side is below the values D3 and D4 (see table) a spacer between this cables required.				
Type ⁽¹⁾	B	E	Weight kg	Order-No.
mm				
DS 26	30	50	0,04	346 710
DS 36	40	60		346 711
DS 46	50	70		346 712

Order details		
Cable loop clamp	Type	Order-No.
Cable arrangement	Number of cables with cable diameter	
Spacer	Type	Order-No.
	Amount	

⁽¹⁾ The type description for hardware made of stainless steel has the addition -K (e.g. LS36-400-K)

TOW ROPE ASSEMBLIES

1. Steel Ropes (Tow Cables)

Recommended for applications with

- Over 30 m Travel Distance (Working Travel)
or in general for mechanical sensitive cables and/or in very dusty environments
- Travel Speeds up to 80 m/min
- Accelerations up to 0.3 m/s²

For higher speeds or accelerations please consult the factory.

Type	Z 4	Z 4-PVC	Z 5	Z 5-PVC	Z 6	Z 6-PVC
Ø d =	6 mm	6/8 mm	6 mm	6/8 mm	8 mm	8/10 mm
Weight	0,125 kg/m	0,150 kg/m	0,125 kg/m	0,150 kg/m	0,221 kg/m	0,250 kg/m
V =	28 mm		42 mm		42 mm	
Material and finish	steel galvanized	steel galvanized PVC-shrouded	steel galvanized	steel galvanized PVC-shrouded	steel galvanized	steel galvanized PVC-shrouded
Admissible tension force (6 times safety factor)	3500 N		3500 N		6100 N	
Type of shackle lock	safety nut		Locknut			
for Cable carrier	W 45		W 120 thru W 140			

Design: Round cord rope made of steel wires with fibre layers, galvanized or additional PVC-shrouding, in prefabricated length, incl. rope-clips, thimbles and shackles.

Weight: Shackles, thimbles, bush = 0.5 kgs on both sides

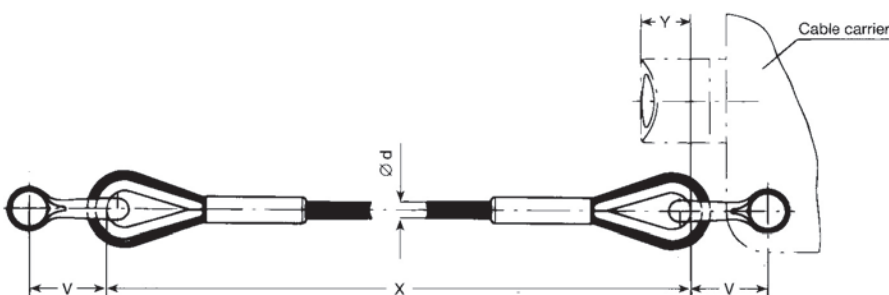

Projecting bumper:

Cable Carrier Type	Y in mm
W 45	0
W 120	-5
W 130 and W 140	35

How to determine the Tow rope Length:

$$X = \frac{S(f - 0,1) + Z}{n} + 2 Y$$

X = Length of tow rope mm
 S = working travel mm
 f = Cable safety factor (1, 15)
 Z = open space mm (min. one carrier)
 n = number of cable loops
 Y = projecting bumper (mm; see table)

Length of Two Rope mm	Order-No.					
	Cable carrier W 45		Cable carrier W 120 thru W 140			
	Z 4	Z 4-PVC	Z 5	Z 5-PVC	Z 6	Z 6-PVC
thru - 2000	346 372	346 383	346 394	346 368	346 405	346 367
2001 - 3000	346 373	346 384	346 395	346 346	346 406	346 356
3001 - 4000	346 374	346 385	346 396	346 347	346 407	346 357
4001 - 5000	346 375	346 386	346 397	346 348	346 408	346 358
5001 - 6000	346 376	346 387	346 398	346 349	346 409	346 359
6001 - 7000	346 377	346 388	346 399	346 350	346 410	346 360
7001 - 8000	346 378	346 389	346 400	346 351	346 411	346 361
8001 - 9000	346 379	346 390	346 401	346 352	346 412	346 362
9001 - 10000	346 380	346 391	346 402	346 353	346 413	346 363
10001 - 11000	346 381	346 392	346 403	346 354	346 414	346 364
11001 - 12000	346 382	346 393	346 404	346 355	346 415	346 365

Please specify with your order

Tow rope: Type
 Length of rope X: mm
 Order- No.:

SPARE PARTS

1. Wheels

wheel	side roller	kick-up roller	for cable carriers	dim. dia x width (mm)	flange wheel	cyl. wheel	wheel material	bush-bearing	ball-bearing	Weight kg	Order-No.
x			W 25 K, W 26 K, W 30 K WN 110, WE 110	45/60 x 24,5	x		polyamid	x		0,027	346 731
x			W 25 KL, W 26 KL W 30 KL	45/60 x 22,5	x		polyamid		x	0,065	346 732
x with axle			W 45 FR	45/60 x 23	x		steel		x	0,230	348 708
		x with axle	W 45 FR	32 x 9		x	steel		x	0,110	348 709
x with axle			W 110 S	45/60 x 21	x		steel		x	0,250	344 750
	x with axle		WE 120								
	x with axle	x with axle	WN 130, WN 140 WE 130, WE 140	45 x 21		x	steel		x	0,200	344 850
x with axle			WN 120 WE 120	80 x 21		x	steel		x	0,810	346 744
x with axle			WN 130, WN 140 WE 130, WE 140	100 x 27		x	steel		x	1,500	346 746

2. Bumpers incl. attachment hardware

dim. dia x length mm	for cable carriers	Weight kg	Order-No.
Ø 26 x 18	W 45 FR	0,010	349 335
Ø 20 x 15 ⁽¹⁾	W 110	0,012	346 001
Ø 30 x 18 ⁽¹⁾	W 120	0,035	344 980
45 x 100 x 52 ⁽¹⁾	W 130, W 140	0,330	345 000

cable clamp LK

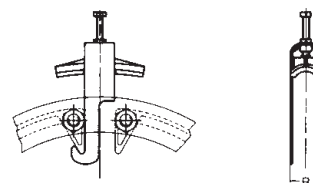

cable clamp LA

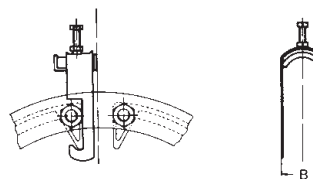

3. Cable clamps for round cable

Clamps, type LA for galvanized steel, compression insert of PVC, hardware galvanized.

clamp type	for Ø mm	dim. B mm	Weight kg	Order-No.
K 12 LA	8–12	16	0,040	345 020
K 16 LA	12–16	21	0,044	345 030
K 20 LA	16–20	24	0,050	345 040
K 24 LA	20–24	29	0,055	345 050
K 28 LA	24–28	33	0,059	345 060
K 32 LA	28–32	37	0,082	345 070
K 36 LA	32–36	41	0,087	345 080
K 40 LA	36–40	46	0,094	345 090
K 44 LA	40–44	50	0,116	345 100
K 48 LA	44–49	54	0,119	345 110

Clamps, type LK for galvanized steel, compression insert of corrosion proof aluminium, hardware of stainless steel.

clamp type	for Ø mm	dim. B mm	Weight kg	Order-No.
K 12 LK	8–12	17	0,102	345 120
K 16 LK	12–16	21	0,105	345 130
K 20 LK	16–20	25	0,132	345 140
K 24 LK	20–24	29	0,142	345 150
K 28 LK	24–28	33	0,152	345 160
K 32 LK	28–32	37	0,180	345 170
K 36 LK	32–36	41	0,185	345 180
K 40 LK	36–40	46	0,210	345 190
K 44 LK	40–44	50	0,230	345 200
K 48 LK	44–49	54	0,240	345 210



TYPICAL APPLICATION AND HOW TO ORDER

Festoon system for round cable

Application:

Electrification system for gantry crane trolley

Cable specification: (see cat. 8 L)

12 cables 1 x 120,0 mm ² , 28,5 mm Ø	trolley travel:	65 m
2 cables 4 x 35,0 mm ² , 42,0 mm Ø	travelling speed:	60 m/min.
2 cables 4 x 25,0 mm ² , 37,5 mm Ø	I-beam track	I NP 200
6 cables 24 x 2,5 mm ² , 38,0 mm Ø	loop depth:	4 m
2 cables 19 x 2,5 mm ² , 33,0 mm Ø	cable length	
5 cables 8 x 2,5 mm ² , 23,0 mm Ø	for termination:	1 x 2 m, 1 x 7 m
3 cables 4 x 2,5 mm ² , 15,5 mm Ø		

How to select the correct system:

1. Choose the correct carriers by considering diameters and weights of the cables per table on pages 14 and 15.

Result:

Tier 1 (upper level): LK 490/ 48 for	2 cables 4 x 35,0 mm ²	Tier 2 (center level): LK 360/12 for	12 cables 1 x 120 mm ²
	2 cables 4 x 25,0 mm ²		
	6 cables 24 x 2,5 mm ²	Tier 3 (lower level): LK 260/ 8 for	5 cables 8 x 2,5 mm ²
	2 cables 18 x 2,5 mm ²		3 cables 4 x 2,5 mm ²

2. The matching trolley chassis: type WN 140 R/490/360/260

3. Find out the quantity of cable loops required per diagram on page 24

Result: 10

4. Find out the storage distance per page 22

Result: 6100 mm + Z (one carrier of 600 mm) = 6700 mm

5. Tow ropes required? See page 18

Answer: Yes

6. Determine length of cable required:

(trolley travel + storage incl. open space Z) x 1.15

+ cable hookup lengths for termination, see page 22.

Result: 92 m

(see page 22)

Material to order:

	Type	Order-No.
9 cable carriers, 3-tier, c/w	WN 140 R/490/360/260	341 610
cable support saddles	LK 490/48	343 270
cable support saddles	LK 360/12	342 780
cable support saddles	LK 260/ 8	342 680
1 lead clamp, 3-tier c/w cable support saddles	M 140 R/490/360/260 (LK as before)	341 640
1 track clamp, 3-tier c/w cable support saddles	E 140 R/490/360/260 (LK as before)	341 670
20 cable loop clamps for upper tier	LS 36-350	347 116
20 cable loop clamps for center tier	LS 26-300	347 104
20 cable loop clamps for lower tier	LS 26-200	347 102
60 distance spacer for lower cable clamp	DS 26	346 710
10 tow rope assemblies, 8 mm dia, 6970 mm long, with hardware	Z 6	346 410
12 x 92 m 92 m Rubber sheathed round cable	H 07 RN-F 1 x 120	332 300
2 x 92 m 92 m Rubber sheathed round cable	H 07 RN-F 4 G 35	330 320
2 x 92 m 92 m Rubber sheathed round cable	H 07 RN-F 4 G 25	330 310
6 x 92 m 92 m Rubber sheathed round cable	A 07 RN-F 24 G 2,5	330 370
2 x 92 m 92 m Rubber sheathed round cable	A 07 RN-F 18 G 2,5	330 360
5 x 92 m 92 m Rubber sheathed round cable	A 07 RN-F 8 G 2,5	330 340
3 x 92 m 92 m Rubber sheathed round cable	H 07 RN-F 4 G 2,5	330 260
24 cable glands	M 32 for 1,5	332 531
4 cable glands	M 50 for 1,5 - 2	332 536
4 cable glands	M 50 for 1,5 - 1	332 532
12 cable glands	M 50 for 1,5 - 1	332 532
4 cable glands	M 50 for 1,5 - 1	332 532
10 cable glands	M 32 for 1,5	332 531
6 cable glands	M 25 for 1,5	332 530

INSTALLATION INFORMATION

with the associated cable carriers

I-Beam Track

1. Install I-beam track parallel with runway of equipment; the side clearance to be sufficient to avoid interference with swinging cables.
2. The support structure for the I-beam must be adequately designed for the anticipated loads. Smooth out welded joints to ensure smooth traversing of cable carriers.

The support of the I-profile has to take place according to the occurring load. The joints have to be carried out aligned. At the tread the welding seams have to be smoothed.

Cable Carrier

The system must be installed in the following order:

1. Cable carriers: adjusted per chosen I-beam
2. Bolt track clamp: to the lower flange of the I-beam
3. Connect lead clamp: The lead carrier of the types W 120 upto W 140 are not carried out as carriers, this units are moving free under the I-profile and will be connected fix with an arm (e. g. U-profile) to the consumer. The arrangement of the arm is apparent in the dimension illustrations of the respective cable carrier types. The cable carriers of the types W 120 upto W 140 are in addition to the absorption of bigger travel inaccuracies equipped with a bumper extension. This bumper extension has to be installed at the first cable carrier behind the lead carrier.

Cables

During installation of the cables please note that the cable length [L] between end clamp and lead carrier is distributed with equally loop depth on the carriers.

$L = (\text{storage length incl. clearance} + \text{travel distance}) \times 1,1 \text{ upto } 1,2$.
During use of tow rope assemblies 1,15 upto 1,25.

The cables will be fixed with single clamps at the cable saddles. They have to be arranged alternating, as shown on the top view of the cable carrier. The locking takes place with counternuts.

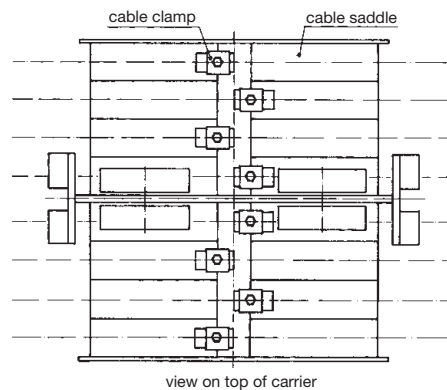

Tow Ropes

Tow ropes (see page 18) are to be installed on the cable carriers by means of shackles.

Cable Loop Clamps

with cable loops of approx. 2,5 m it is recommended to use one cable clamp at the lower vertex of each loop. Use two cable clamps in the lower third (one each side of the loop) when the loop depth exceeds 2 m.

Make test runs

HOW TO DETERMINE: Storage Distance, Cable Length, Number of Carriers

Cable Safety Length Directions

travelling speed	cable loop	safety factor
up 35 m/min	more than 0.3 m	f = 1,1
up 50 m/min	up to 0.8 m	f = 1,15
up 50 m/min	more than 0.8 m	f = 1,1
up 80 m/min	up to 0.8 m	f = 1,2
up 80 m/min	more than 0.8 m	f = 1,15
for spiral looped round cable		f = 1,2

For higher speed factors (> 80 m/min) please consult factory.

Storage distance

$$SP = n \times l + Z$$

Cable length

(c/c track clamp – lead clamp without hookup on both ends)

$$L = (S + SP) \times f$$

Number of Carriers

(without lead clamp and track clamp)

$$= n - 1$$

- S = travel distance (m)
- SP = storage distance (m)
- Z = open space (m)
(min. one carrier)
- n = number of loops
- l = length of carrier (m)
- f = cable safety factor

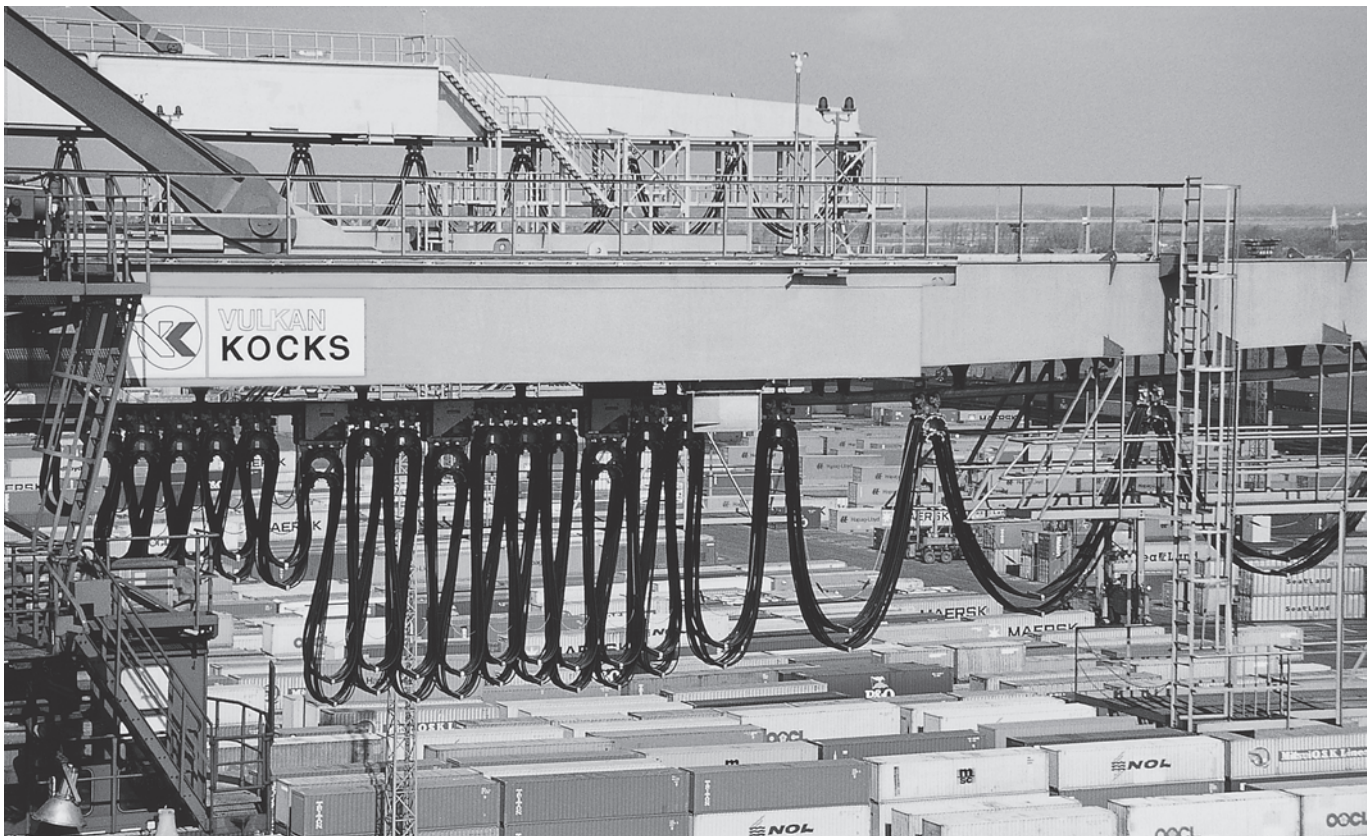

VAHLE cable carriers in Bremerhaven

CABLE LOOPS

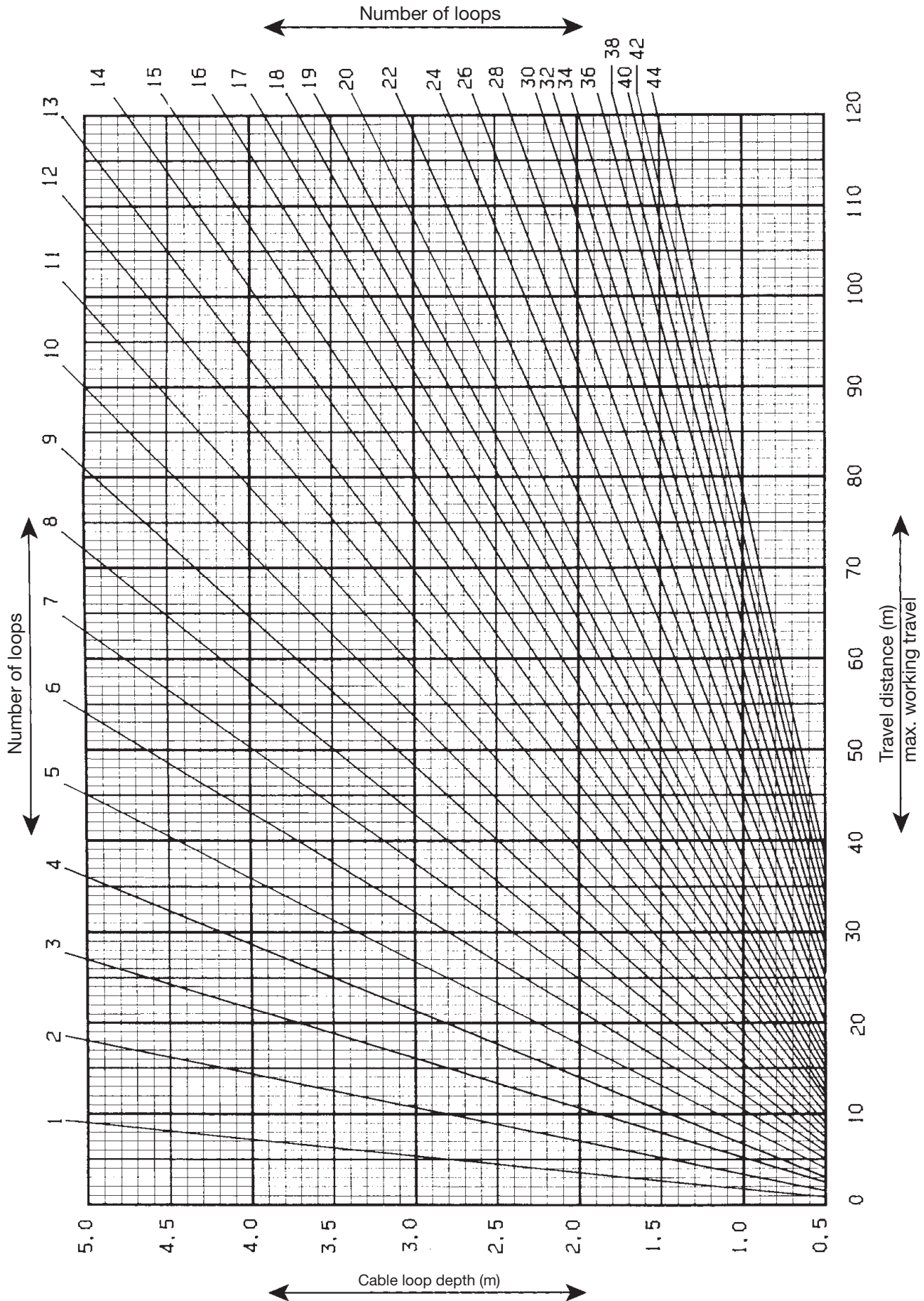

The diagram considers a cable safety length factor of $f=1.10$

CABLE LOOPS

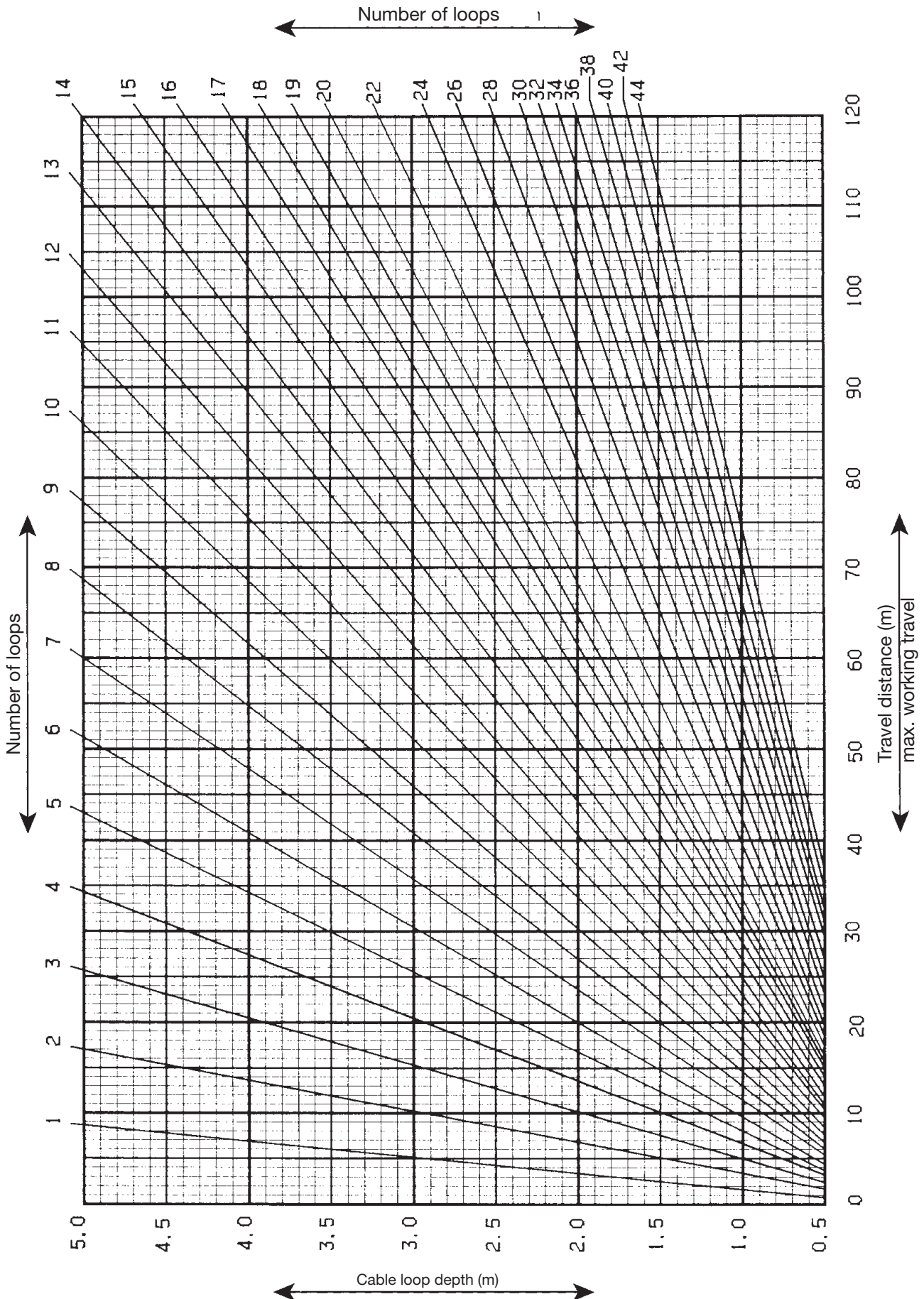

The diagram considers a cable safety length factor of $f=1.15$

CABLE LOOPS

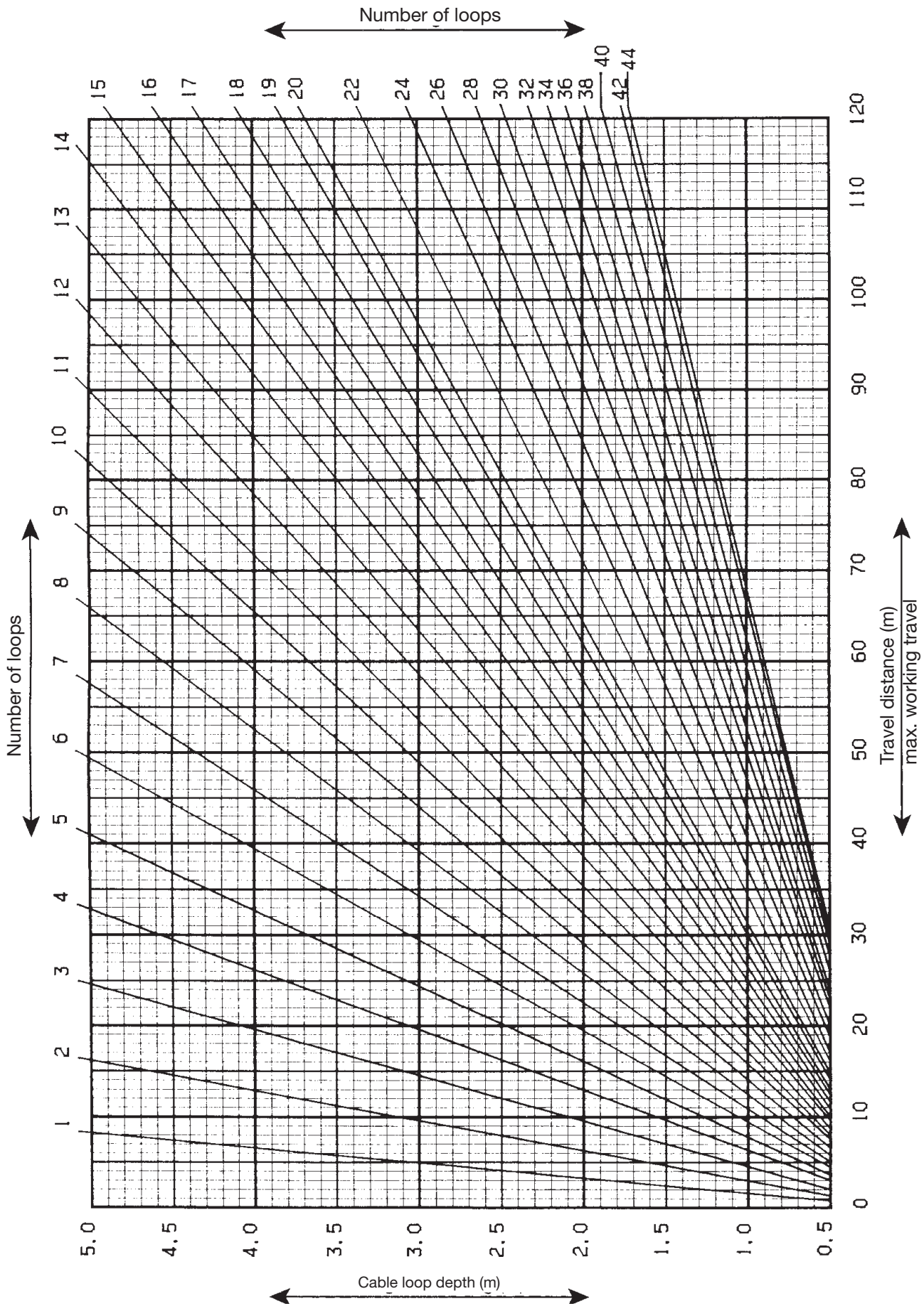

The diagram considers a cable safety length factor of $f=1.20$

APPLICATION PHOTOS



VAHLE cable carriers at Hamburg harbour



NOTES



Paul Vahle GmbH & Co. KG

Westicker Str. 52
59174 Kamen
Germany

+49 2307 7040
info@vahle.com
vahle.com

You can find your local contact at:

vahle.com/contact