

Sveriges mest
kompleta leverantör
av rörlig
strömmatning

Sliprings type PRS

KranEl överför kraft i rörelse



Main performances

Housing	In aluminium
Positioning	In vertical axis with threaded pipe as illustrated here below
Cable entry	To connect rings to the clamp, through the tube and to the brush-holders cable entry through the PG 21
Brushes	20 A copper-graphite brushes / silver-graphite for signals,
Executions	From 6 to 15 rings 20 A, from 4 to 14 rings 30 A and from 4 to 10 rings 50 A
Armonized rules	EN 60947 - 5 - 1 EN 60529 2006/95/CE - 2004/108/CE - 2006/42/CE
Marking	CE

Electrical features

Nominal voltage	660 V ac—dc
Nominal current	I _{th} 20 A - 30 A - 50 A
Protection degree	IP 55
Max rotation speed	30 revs/min
Test voltage	2,5 kV
Operating temperature	- 20 °C — + 60 °C

Availability on demand:

- Mixed versions with 20 A / 30 A / 50 A rings
- Signal versions with gold or silver rings

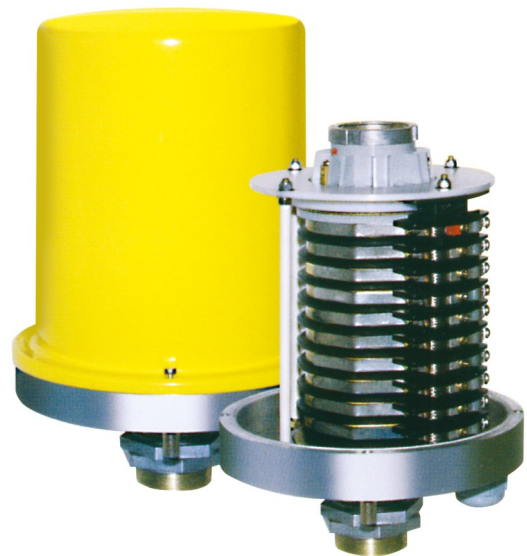

Standard types

20 A type	N° Rings	30 A Type	N° Rings	50 A Type	N° Rings	H = mm
G PRS B6	6	G PRS C4L	4	G PRS D4L	4	192
G PRS B9	9	G PRS C6L	6	-	-	192
G PRS B12	12	G PRS C8L	8	G PRS D6L	6	252
G PRS B15	15	G PRS C10L	10	-	-	252
-	-	G PRS C12L	12	G PRS D8L	8	312
-	-	G PRS C14L	14	G PRS D10L	10	312

For 30 A and 50 A executions, please omit the final “L” of the code if you need copper-graphite brushes

Installation and wiring

The PRS sliping has to be installed only by qualified personnel in compliance with current safety standards. Power to the machine must be turned off before carrying out cabling. Connections are to be made in compliance with the wiring scheme of the controlled equipment. After installation has been completed, the installer is required to check that all commands are working properly. Avoid prolonged contact with oils and acids when using the equipment, as these may damage the products.

- 1) Using the locknuts (Ref. 11), attach the central pipe (Ref. 3) to a minimum 3 mm thick plate with a central hole of $\varnothing 48.5 \div 52.5$ mm (using the reducing cable clip on the nuts). As an alternative the central pipe (Ref. 3) can be attached to a plate with a threaded hole of $\varnothing 48$ mm, 1.5 mm pitch using the locknuts as jam nuts (Ref. 11).
- 2) Rotation is achieved thanks to 2 $\varnothing 10$ mm pivots (Ref. 8) situated on the base (Ref. 1) at a distance of 160 mm from each other. We recommend the coupling to be made with slack to take up any possible runout during rotation. Rotation can also be achieved by attaching the base (Ref. 1) using the two pivots (Ref. 8) situated on the plate, thus enabling the central pipe to rotate by (Ref. 3) thanks to a suitable coaxial joint.
- 3) The cables are connected to the brushes through the pipe union PG21 (Ref. 24). Please ensure that the wires do not interfere with any moving parts. The rings are connected to the terminal board through the central pipe (Ref. 3).
- 4) Please check the equipotential of any surfaces not generally recommended to be used under tension, and the ground connection using the cables provided

Maintenance

A programme of periodical maintenance is required to be carried out to ensure that the PRS sliping is kept in perfect working order. All maintenance is to be effected by qualified personnel using only original spare parts. Any defective or altered parts must be replaced promptly, even outside the maintenance schedule, as they could impact on the safety of the device. In particular:

- 1) Disconnect from power source and wait until the internal parts have cooled down.
- 2) Remove the cover (Ref. 6).
- 3) Copper-graphite brushes execution : check the brushes for wear and tear, and check that they fit properly to the rings. Blade brushes execution : check the brushes and rings for wear and tear.
- 4) Copper-graphite brushes execution : remove copper-graphite dust with dehumidified compressed air or a clean brush. Blade brushes execution : remove dust or grease and grease again with a suitable lubricant.
- 5) Check tightness of cables.
- 6) Check that the cover seal is in good condition.
- 7) Replace cover (Ref. 6).

Please note that the guarantee does not cover any equipment whose parts have been modified and tampered. RAVIOLI declines any responsibility for damage deriving from incorrect installation or use of the product.

Dimensions

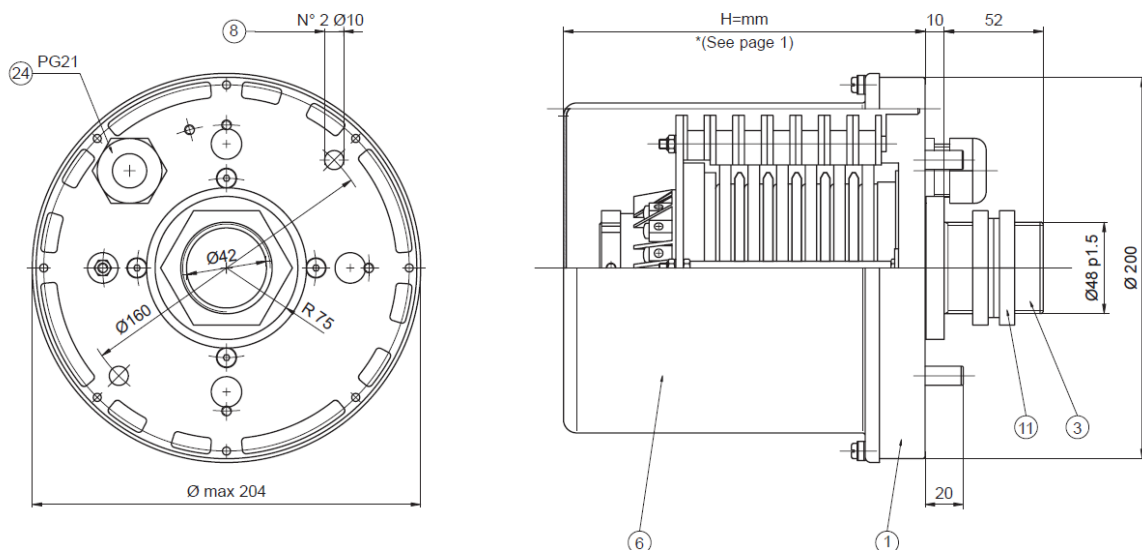

Vår erfarenhet är din
driftsäkerhet och
konkurrenskraft

Ditt mål är vårt

Vårt mål är att ni ska få ut mer av er anläggning eller maskin och bli mer konkurrenskraftig. Ökad konkurrenskraft tror vi uppnås delvis genom en optimal funktion, problemfri drift samt minskade drift- och underhållskostnader. Därför erbjuder vi allt från reservdelar till helhetslösningar med effektiv logistik.

Helhetslösning

Vi hittar den optimala lösningen för er, gärna redan på utvecklingsstadiet.

Problemlösning

Problem med befintliga applikationer? Med vår långa erfarenhet kan vi lova att vi stött på liknande problem tidigare. Prata med oss så löser vi det.

Produkt

Vi ser till att du får det du behöver med snabbast möjliga leverans.

Reservdel

Ibland räcker det med en reservdel för att få anläggningen att rulla igen. Osäker på vilken del du söker? Vi hjälper dig hitta rätt produkt.

KranEl Göteborg

Vagnmakaregatan 14
415 72 Göteborg
Tel: +46 (0)31 340 90 70

Mail: office@kranel.se

KranEl Stockholm

Reprovägen 12
183 77 Täby
Tel: +46(0)8 756 00 95