

FESTOON SYSTEMS FOR ◇-TRACKS





CONTENTS

	Page
General information	2
Questionnaire	3
Diamond Track V 3 and Accessories	4, 5
Cable Carriers for V 3	5
Lead Carriers and Track Clamps for V 3	6
Control Carriers and Accessories for V 3	7
Example for Ordering	8
Installation Tools, diagram	9
Table determining the storage distance and number of carriers	10, 11

General

VAHLE-Festoon systems support electric cables or hoses for mobile machinery.

The cable carriers contained in this catalog comply with VDE regulations. Diamond tracks are especially well suited for curved installations.

Application

Cable carriers ride on the square bar parallel to the traversing track of the equipment. This arrangement ensures that the total length of equipment (e.g. hoist, crab, trolley, etc.) is used as storage distance for the carriers (see sketch below). The first carrier (lead carrier) is connected to the equipment by an outrigger and towed along the diamond track.

All carriers are connected to each other via the cables or hoses installed. Depending on the cable/hose package, the loop, the speed, the acceleration and the type of curve radii it might be necessary to consider tension relief elements.

Important for proper performance:

- a) Consider min. permissible bending radii of cables
- b) Consider a cable loop safety length of 10-15% for straight runs and 20% for curved tracks.

Layout

The types of cables are determined according to the required number of conductors and the current load of the equipment (see cat. 8L). The dimensions of cables are the basis for the selection of the carrier type. The length of cable results from active travel distance plus storage distance, extra safety length plus end connections (see installation information).

Consider a multiplier of 0.7 x smallest radius for the maximum permissible cable loop in curved installations. The maximum permissible speed depends on the total amount of curve angles.

For systems specification please refer to the example for ordering in this catalog.

We welcome your inquiry on your particular application. Kindly consult your local Vahle agent or the factory using the questionnaire and submitting a system layout.

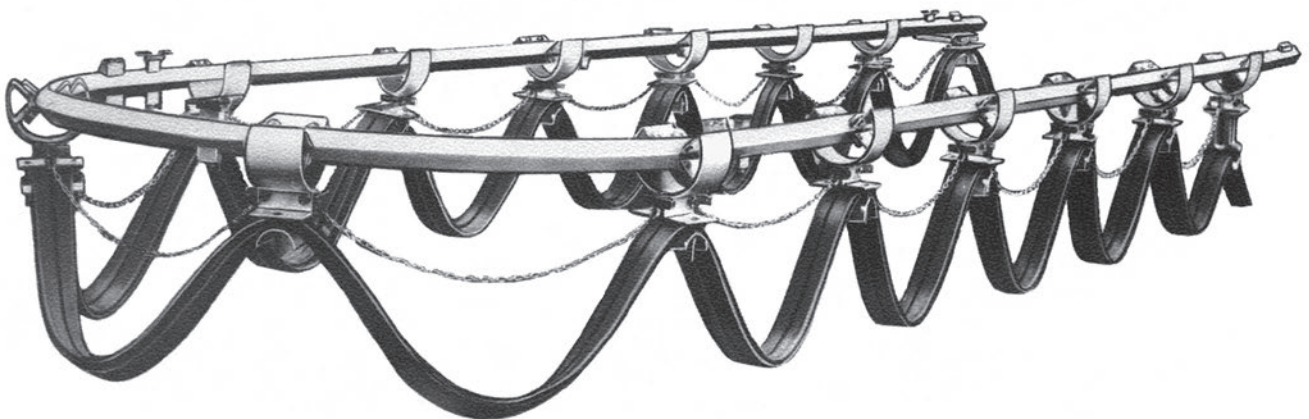

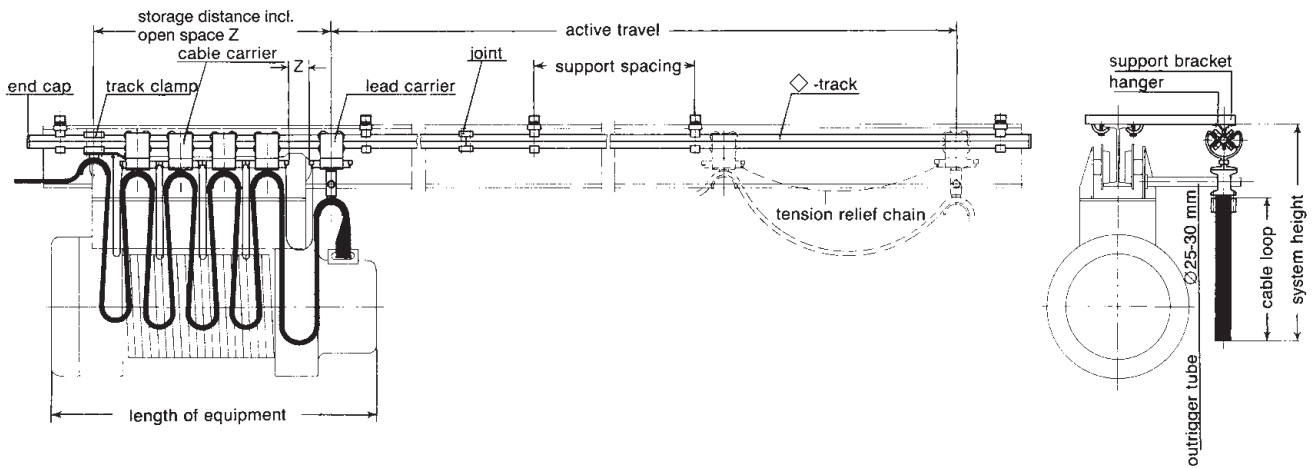

Name and Address of Customer: _____

Ref.: _____

1. Type of Application _____

2. Outdoors indoors _____

3. Temperature range _____ ° C min. _____ ° C max. _____

4. Is round or flatform cable envisaged? _____

5. How much space is available for storage? _____ mm

6. Is it possible to extend the track for the festoon cable system in case the length of equipment is insufficient for storage space?
 Yes, by _____ mm, no, not possible.

7. Special operating conditions: _____

8. Length of crane trolley: _____ mm

9. Travel distance of crane trolley: _____ mm

10. Travelling speed: _____ m/min.

11. Max. loop depth: _____ mm

12. Further details: _____

12. Required cables:

No. of cables	No. & size of conductors	ø mm	width x thickness of flatform cables

Please, submit the completed Questionnaire together with your inquiry. Your system layout drawing will be appreciated in case of curves.



V 3 TRACK AND ACCESSORIES

Track

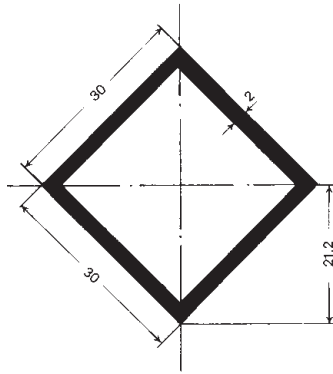

Type	V 3
Order- No.	360 196
Order- No. for bending	360 026
For cable carrier	WV 3
Material	steel
Surface protection	galvanized
Supply lengths	6 m
Standard support spacing	2 m (1 m in storage section and curves)
Moment in inertia Jx	2,94 cm ⁴
Section modulus Wx	1,39 cm ³
Weight	1,77 kg/m

Other support centers and permissible area loads

Support spacing	1 m	1,5 m	2 m	2,5 m	3 m	3,5 m
perm. area load	111 kg	74 kg	47 kg	30 kg	21 kg	15 kg

Joint clamp

Type	WV 3
Order- No.	360 018
Material	steel/aluminium
Surface protection	galvanized
Weight	0,125 kg

torque moment 10 Nm

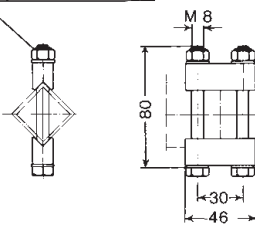

End cap

Type	K 30
Order- No.	360 023
Material	polyethylene
Weight	0,008 kg



Hanger

underhung

Type	ADV 3
Order- No.	360 019
Material	steel/aluminium
Surface protection	galvanized
Weight	0,11 kg

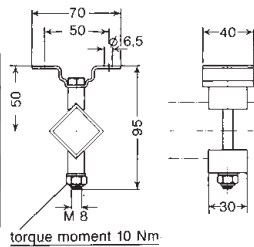

torque moment 10 Nm

Hanger

underhung for HK support

Type	AKV 3
Order- No.	360 020
Material	steel/aluminium
Surface protection	galvanized
Weight	0,19 kg

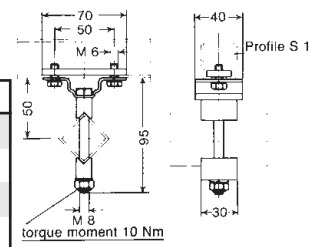

2 bolts M 6 x 30, order- No. 360 030 to be ordered separately

Support bracket

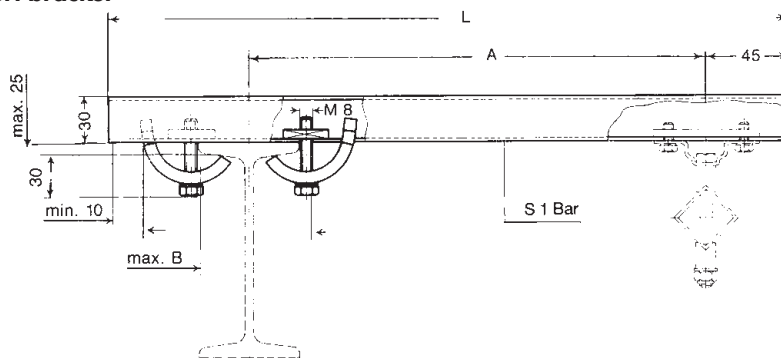

Dim A depends on width of machinery (e.g. crane trolley). Make sure that hoist wheels have enough clearance.

Type	Material	Surface protection	Weight kg	A (adjustable) mm	L mm	max. B mm	Order- No.
HK 200	steel	galvanized	0,980	200	400	210 ⁽¹⁾	310 220
HK 300			1,130	300	500	210 ⁽¹⁾	310 230
HK 400			1,290	400	600	210 ⁽¹⁾	310 240
HK 500			1,430	500	700	210 ⁽¹⁾	310 250

Our delivery: 1 pair of claws and track S1. Hangers AKV 3 to be ordered separately.

ACCESSORIES AND CABLE CARRIERS FOR V 3 TRACK



Claw for HK

Type	SP
Order- No.	310 390
Material	steel
Surface protection	galvanized
Weight	0,200 kg

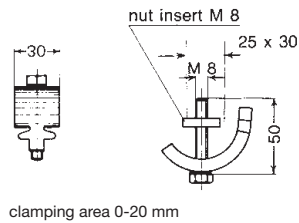

Flat nut M 8 separately available
Order- No. 310 955.

Support Attachment for HK

Type	AH 1
Order- No.	310 400
Material	steel
Surface protection	Hardware galvanized
Weight	0,460 kg

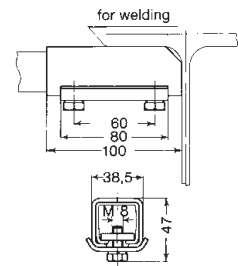

Bracket bars and hangers to be ordered separately.

Bracket bars for HK

Type	Material	Surface protection	Weight kg	L mm	Order- No.
S 1 - 400	steel	galvanized	0,620	400	310 600
S 1 - 500			0,780	500	310 610
S 1 - 600			0,930	600	310 620
S 1 - 700			1,090	700	310 630

Cable Carriers for V 3 Track

Engineering data

Type	WV 3-25 F for indoor use	WV 3-32 F for indoor and outdoor use
Wheels	Ball bearings \varnothing 25, galvanized Z-sealed Temperature resistance lub grease: -30° to $+125^{\circ}$ C Travelling speed: max. 80 m/min.	Ball bearings \varnothing 32, galvanized RS-sealing Temperature resistance lub grease: -30° C to $+125^{\circ}$ C Travelling speed: max. 100 m/min.
Material	Carrier body: Aluminium Bumper plates: Steel, galvanized Support saddle: Steel, galvanized Hardware: galvanized	
Loop depth	max. 3.5 m with max. cable load (max. 20 kg per carrier)	max. 3.5 m with max. cable load, (max. 25 kg/carrier)

Cable Carriers for Flatform Cable

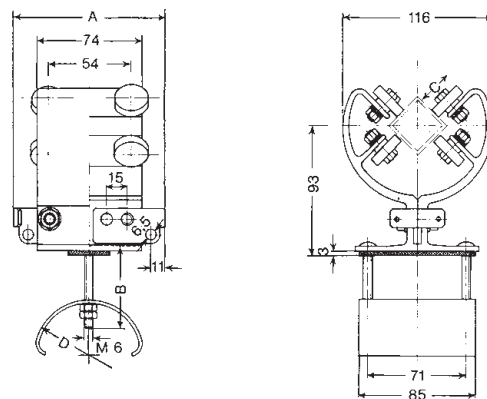

Type	Cable	max. thickness of individual cable mm	max. clamping capacity in mm height x width	A	B	C	D	Weight kg	Order- No.
				mm					
WV 3-25 F/50-110	flat-form	7,9	30 x 65	110	60	25	50	0,90	360 000
WV 3-25 F/50-140			45 x 65	140	80				360 001
WV 3-25 F/80-110		10,0	15 x 65	110	60		80	0,96	360 004
WV 3-25 F/80-140			30 x 65	140	60				360 005
WV 3-32 F/50-110	flat-form	7,9	30 x 65	110	60	32	50	1,05	360 002
WV 3-32 F/50-140			45 x 65	140	80				360 003
WV 3-32 F/80-110		10,0	15 x 65	110	60		80	1,11	360 006
WV 3-32 F/80-140			30 x 65	140	60				360 007



V 3 LEAD CARRIERS AND TRACK CLAMPS3

Lead Carriers for flat form Cable

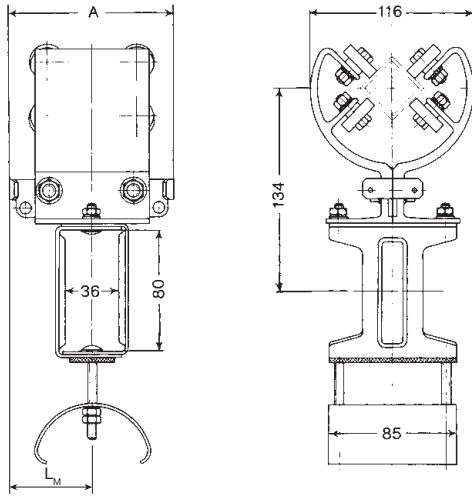

Type	for Cable carriers	L _M	Cable	A mm	Weight kg	Order- No.
MV 3-25 F/50-110	WV 3-25 F/50-110	55	flat- form	110	1,27	360 008
MV 3-25 F/50-140	WV 3-25 F/50-140	70		140		360 009
MV 3-25 F/80-110	WV 3-25 F/80-110	55		110	1,33	360 012
MV 3-25 F/80-140	WV 3-25 F/80-140	70		140		360 013
MV 3-32 F/50-110	WV 3-32 F/50-110	55	flat- form	110	1,42	360 010
MV 3-32 F/50-140	WV 3-32 F/50-140	70		140		360 011
MV 3-32 F/80-110	WV 3-32 F/80-110	55		110	1,48	360 014
MV 3-32 F/80-140	WV 3-32 F/80-140	70		140		360 015

Track clamps c/w bumper for flatform Cable

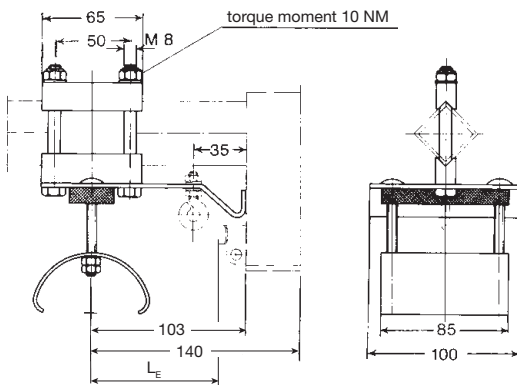

Type	for Cable carriers	L _E	Cable	Weight kg	Order- No.
EV 3-F/50	WV 3-25 F/50-110	85	flatform	0,66	360 016
	WV 3-25 F/50-140	70			
	WV 3-32 F/50-110	85			
	WV 3-32 F/50-140	70			
EV 3-F/80	WV 3-25 F/80-110	85	flatform	0,73	360 017
	WV 3-25 F/80-140	70			
	WV 3-32 F/80-110	85			
	WV 3-32 F/80-140	70			

V 3 CONTROL CARRIERS AND ACCESSORIES



Control Carriers

Type	D	E	F	G	Weight kg	Order- No.
	mm					
ST-V3-32/A1	190	150	38	100	4,9	360 138
ST-V3-32/A2	280	200	62	140	6,3	360 139

Ausführung

Carrier body: aluminium	Support bar: aluminium
Wheels: steel ball bearings	Terminal box: noryl
Max. cable load: 25 kg	
Temperature resistance: - 30° C to + 100° C	

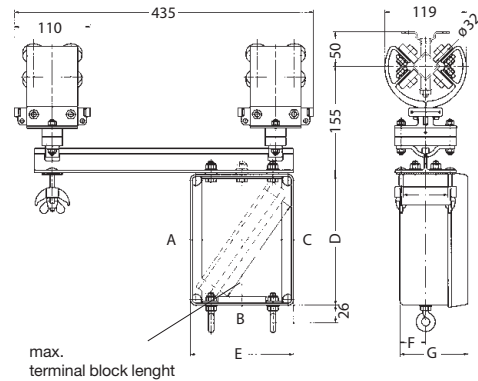

Attention: The junction box is to be grounded with terminal block Type EK 2.5 N PA!

ST-V3-32/A1			ST-V3-32/A2		
Cable glands	max. number A-Side	max. number B-Side	Cable glands	max. number A-Side	max. number B-Side
M 20 x 1,5	6	2	M 20 x 1,5	12	6
M 25 x 1,5	5	1	M 25 x 1,5	10	6
M 32 x 1,5	3	1	M 32 x 1,5	8	4
M 40 x 1,5	2	1	M 40 x 1,5	4	2
M 50 x 1,5	2	1	M 50 x 1,5	3	1
M 63 x 1,5	-	-	M 63 x 1,5	3	1

Max. length of Terminal block A1 = 130 mm
A2 = 220 mm

Bumper

required c/w control carriers

Type	PV 3
Order- No.	360 021
Material	steel/aluminium
Weight	0,49 kg

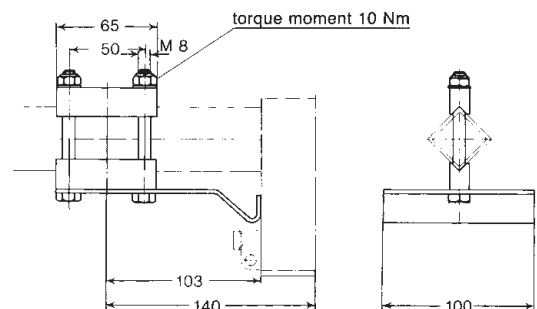

Strain Relief Chain c/w Accessories

Type	ZEK
Order- No.	360 027
Material	steel
Surface Protection	galvanized
Weight kg/m	0,075

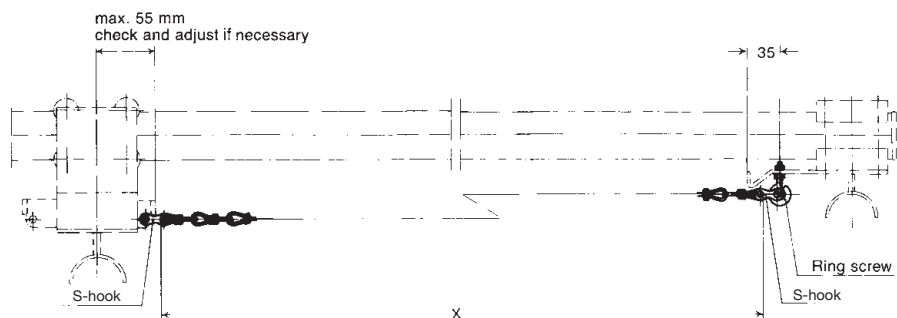

Accessories:

Each piece of chain requires:
2 S-hooks, Order- No. 360 390.

Each Track clamp requires:
1 ring screw RS, Order- No. 360 029.

$$X = \frac{(F \times 1,05) + Z}{n + 1}$$

- X = Chain length in mm
- F = Travel distance of lead carrier in mm
- n = Number of cable carriers (w/o lead carriers and end clamps)
- 1,05 = Safety length factor
- Z = Open space in storage section (see page 11, point 5)



EXAMPLE FOR ORDERING

Inquiry: Hoist on track per drawing – Indoor Installation –

Travelling speed:	30 m /min.
Cables:	1 PVC-flatform (K) H 07 VV H 2 - F 4 G 4 (7,1 x 22 mm) 1 PVC-flatform (K) H 07 VV H 2 - F 8 G 2,5 (5,9 x 35,7 mm)
max. Cable loop depth:	1 m (per structural environment)
required hookup cable end connections:	1 x 2 m + 1 x 5 m

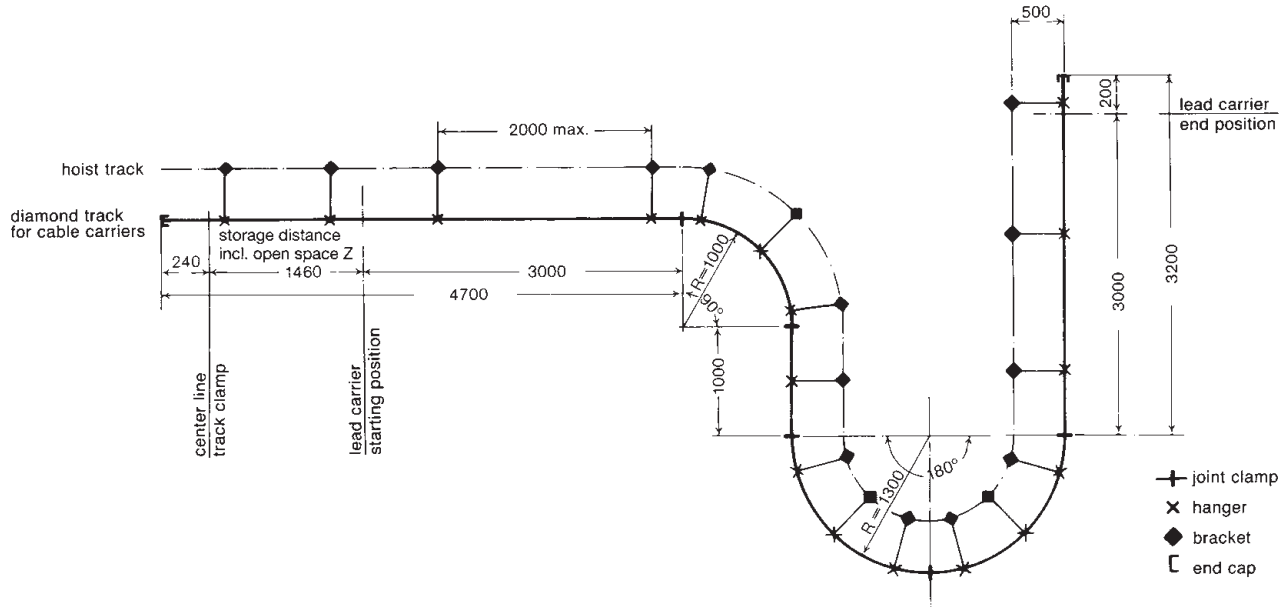

How to select the correct system:

- Calculation of lead carrier's active travel
 $3000 \text{ mm} + \frac{2 \times 1000 \text{ mm} \times \pi \times 90^\circ}{360^\circ} + 1000 \text{ mm} + \frac{2 \times 1300 \text{ mm} \times \pi \times 180^\circ}{360^\circ} + 3000 \text{ mm} = \mathbf{12660 \text{ mm}}$
- Max. permissible cable loop depth (see page 9)
 $0,7 \times R_{\min.} = 0,7 \times 1000 \text{ m} = \mathbf{700 \text{ mm}}$
 ($R_{\min.}$ = smallest curve radius of the system)
- Checking the travelling speed (see diagram page 9)
 Total of curve angles: $90^\circ + 180^\circ = 270^\circ$
 Smallest curve radius: 1000 mm
 That means okay for max. travelling speed of $\mathbf{30 \text{ m/min.}}$
- Selection of carriers (see page 5) $\mathbf{WV 3-25 F/50-110}$
- Find out the quantity of carriers required (see diagram, pages 10/11) $\mathbf{11 \text{ Stück}}$
- Find out the storage distance (see page 10) plus 1 carrier length open space
 $1350 \text{ mm} + 110 \text{ mm} = \mathbf{1460 \text{ mm}}$
- Find out length of each strain relief chain (see formula page 7)
 $X = \frac{(12\ 660 \times 1,05) + 110 \text{ mm}}{12} = 1117 \text{ mm}$
 Total chain length: $12 \times 1117 \text{ mm} = 13404 \text{ mm} \approx \mathbf{ca. 14 \text{ m}}$
- Length of cable required (chain length + storage distance) x cable loop safety length + 7000 mm for hockup cable end connections $(12\ 660 + 1460 \text{ mm}) \times 1,2 + 7000 \text{ mm}$ for connections $\approx \mathbf{ca. 24 \text{ m}}$

Material to order:

Qty.	material	Order- No.
14,555 m	square bar track, type V 3 in 1 x 4.7 m 1 x 1.571 m (curve) 1 x 1 m 2 x 2.042 m (curves) 1 x 3.2 m extras for curved sections 1 x 90° R = 1000, L = 1571 mm 2 x 180° R = 1300, L = 2 x 2042 mm ⁽¹⁾ Surcharge for bending per section	360 025
5	joint clamps VV 3	360 018
2	end caps KV 3	360 023
17	hangers AKV 3	320 020
17	brackets HK 500	310 250
11	cable carriers Typ WV 3-25 F/50-110	360 000
1	lead carrier Typ MV 3-25 F/50-110	360 008
1	track clamp with bumper Typ EV 3-F/50	360 016
14 m	chain ZEK	360 027
24	chain buckles KSS	360 028
1	ring screw Typ RS	360 029
24 m	plastic flat cable (K) H 07 VV H 2 - F 4 G 4 (7,1 x 22 mm)	330 180
24 m	plastic flat cable (K) H 07 VV H 2 - F 8 G 2,5 (5,9 x 35,7 mm)	330 160
2	cable glands M 32x1,5 for 4 x 4 mm ²	330 920
2	cable glands M 40x1,5 for 8 x 2,5 mm ²	330 990
1	drill-jig BV 3-50/15	360 024
2	drill ø 8,5 x 90°	360 032



Drill-jig

(see installation information)

Type	BV 3-50/15
Order- No.	360 024
Material	aluminium, drill inserts hardened steel
Weight	0,75 kg

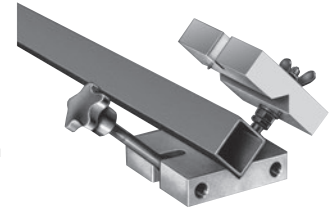
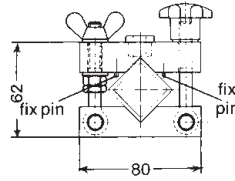
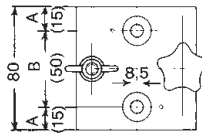

Spiral Driller

Type	Ø 8,5 x 90°
Order- No.	360 032
Material	HSS

Angle of Drill $\leq 90^\circ$.

Diagram for permissible travelling speed in curves

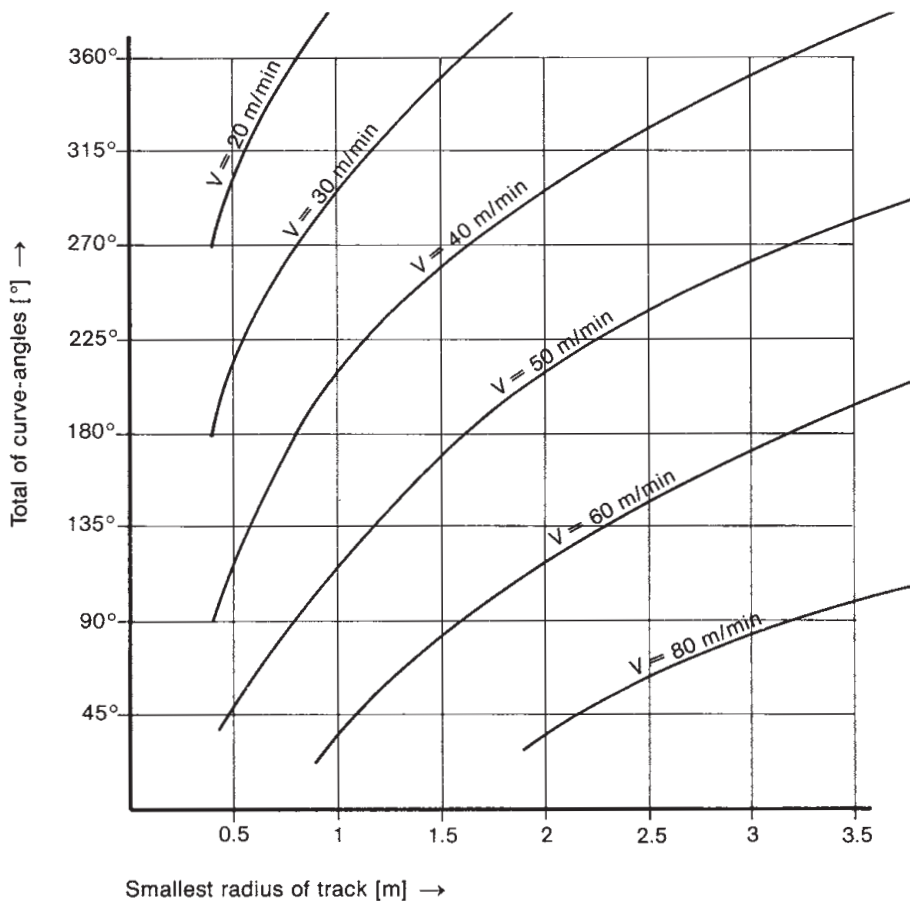

Max. permissible cable loop for installations with curves

$$= 0,7 \times \text{smallest curve-radius of track layout}$$



DETERMINING STORAGE DISTANCE AND NUMBER OF CARRIERS

(The Diagram considers a cable loop safety length of 20%)

Number of carriers	carrier type		Number of carriers
	WV 3-25 F/50-110 WV 3-25 F/80-110 WV 3-32 F/50-110 WV 3-32 F/80-110	WV 3-25 F/50-140 WV 3-25 F/80-140 WV 3-32 F/50-140 WV 3-32 F/80-140	
storage distance (mm) w/o factor Z			
55	6190	7840	55
54	6080	7700	54
53	5970	7560	53
52	5860	7420	52
51	5750	7280	51
50	5640	7140	50
49	5530	7000	49
48	5420	6860	48
47	5310	6720	47
46	5200	6580	46
45	5090	6440	45
44	4980	6300	44
43	4870	6160	43
42	4760	6020	42
41	4650	5880	41
40	4540	5740	40
39	4430	5600	39
38	4320	5460	38
37	4210	5320	37
36	4100	5180	36
35	3990	5040	35
34	3880	4900	34
33	3770	4760	33
32	3660	4620	32
31	3550	4480	31
30	3440	4340	30
29	3330	4200	29
28	3220	4060	28
27	3110	3920	27
26	3000	3780	26
25	2890	3640	25
24	2780	3500	24
23	2670	3360	23
22	2560	3220	22
21	2450	3080	21
20	2340	2940	20
19	2230	2800	19
18	2120	2660	18
17	2010	2520	17
16	1900	2380	16
15	1790	2240	15
14	1680	2100	14
13	1570	1960	13
12	1460	1820	12
11	1350	1680	11
10	1240	1540	10
9	1130	1400	9
8	1020	1260	8
7	910	1120	7
6	800	980	6
5	690	840	5
4	580	700	4
3	470	560	3
2	360	420	2
1	250	280	1
storage distance (mm) w/o factor Z			

1. The active travel distance of the lead carrier to be plotted on the horizontal axis (equals the machinery travelling distance with straight runs; in case of curves see runway calculation on page 8).
2. Draw an upward vertical line from this point.
3. Where this vertical axis upward intersects with the sloping line (loop depth; also see formula on page 9) now draw a horizontal axis to the left.

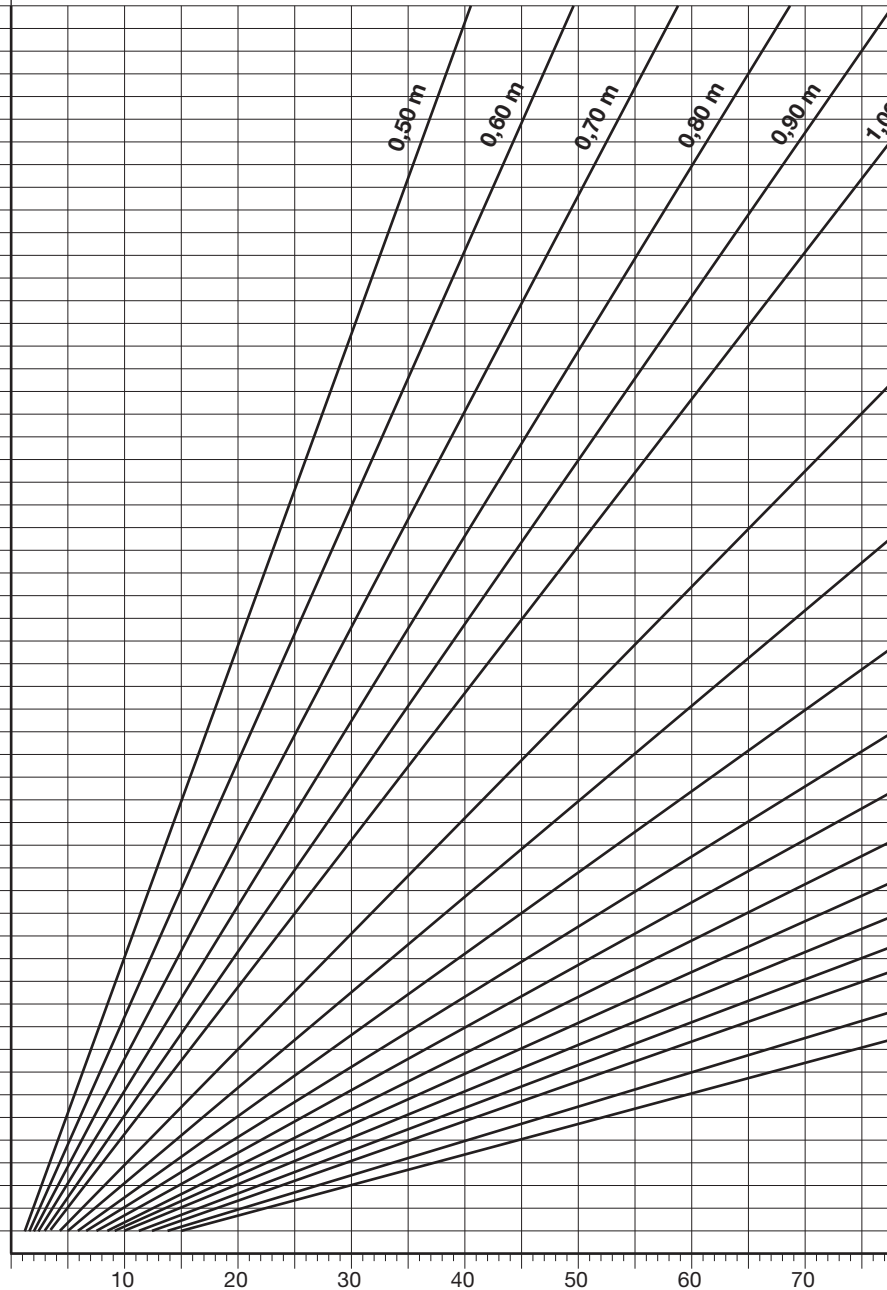

For straight runs → machinery travelling distance in meters
 For curved runs → active travel distance of lead carrier in meters

DETERMINING STORAGE DISTANCE AND NUMBER OF CARRIERS



4. There, at the vertical axis you find the required number of carriers, track clamp and lead carrier not included. Always select the next larger quantity when your line ends up between two numbers.
5. The table on the left shows the required storage distance for the chosen type and number of carriers (considering all carriers, 1/2 of lead carrier and 1/2 of track clamp pushed closely together). Allow approx. one carrier length for the open space Z (see details on page 3).

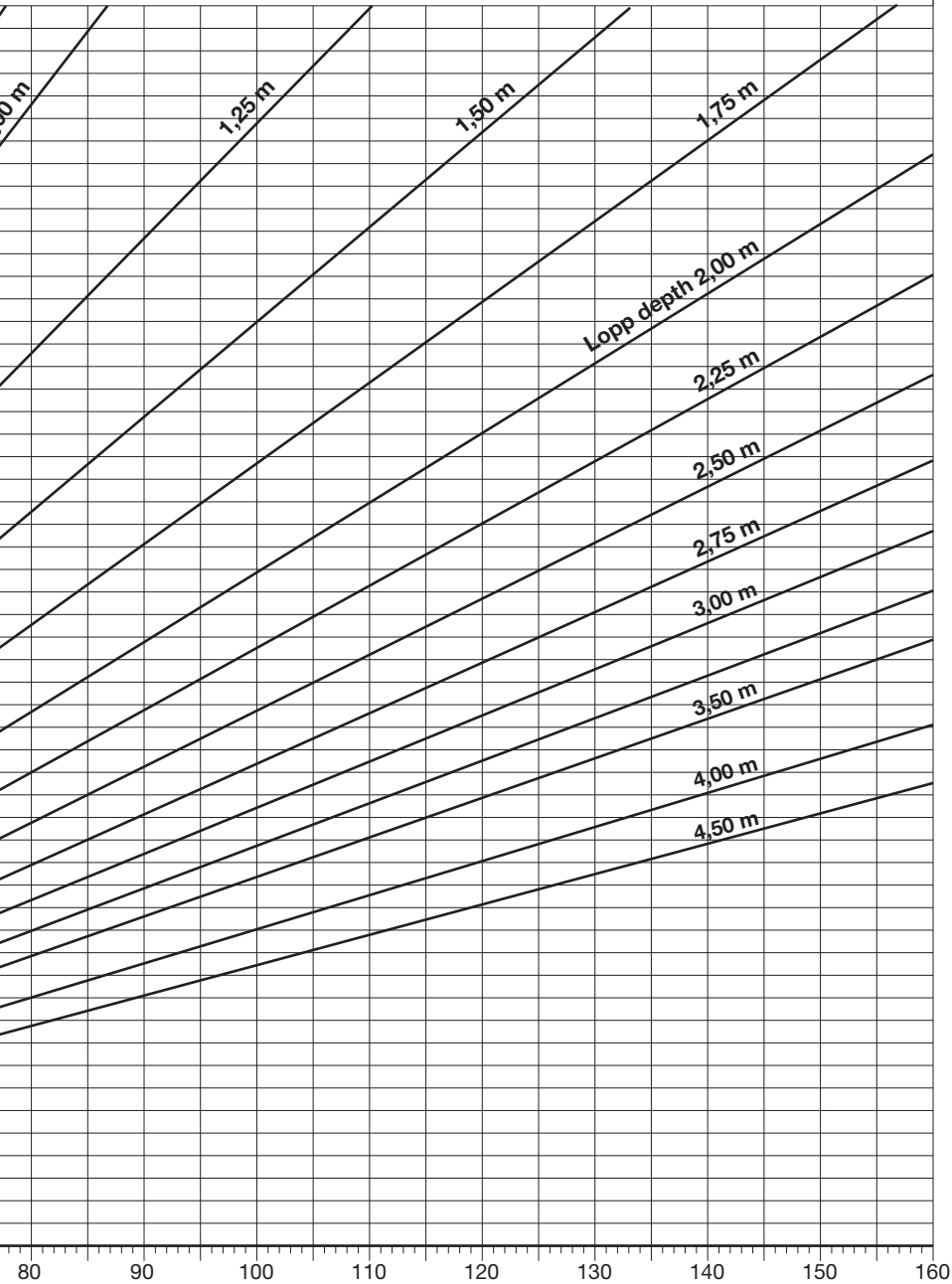



Paul Vahle GmbH & Co. KG

Westicker Str. 52
59174 Kamen
Germany

+49 2307 7040
info@vahle.com
vahle.com

You can find your local contact at:

vahle.com/contact