

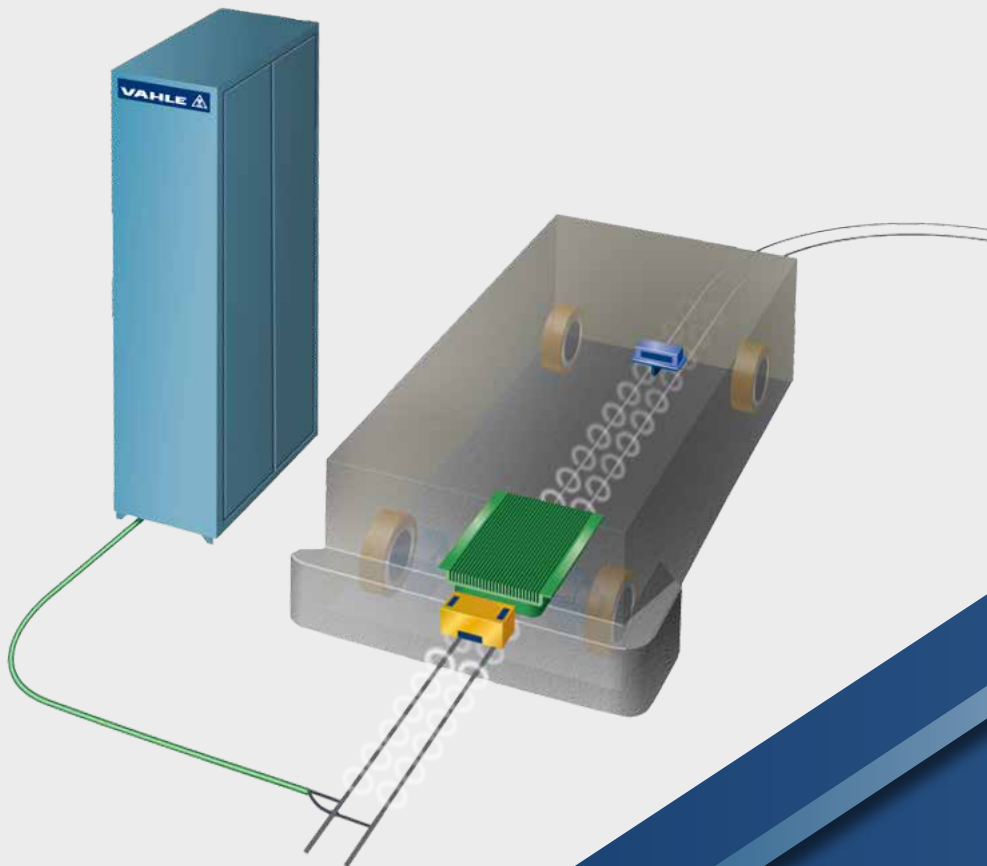

**CPS® – CONTACTLESS POWER SUPPLY  
20 KHZ TECHNOLOGY**



## CPS® – KEY HIGHLIGHTS



### GLOBAL USE

The VAHLE CPS® is used in many branches of industry with more than 450 installations realized worldwide. This includes the great “know-how” of VAHLE and finding individual solutions together with the customer.



### HIGH EFFICIENCY

Due the exceptionally low track current of only 72/124A and modern power electronics, there is a particularly high efficiency and good electromagnetic compatibility (EMC).

### HIGHEST SYSTEM AVAILABILITY

The CPS® convinces with its wear- and largely maintenance-free power supply. In addition, the VAHLE systems are resistant to contamination and meet the requirements of high-speed applications. Of course, optimum efficiency can only be guaranteed under appropriate environmental and mechanical conditions.



### WIDE RANGE OF SERVICES

The CPS® has been continuously further developed since 1997 – with the emphasis on important criteria such as economic coverage of a large performance range.



# GENERAL CPS® OPERATING PRINCIPLE

## TRANSFORMER PRINCIPLE

VAHLE CPS® technology provides electrical energy without any mechanical contact. It utilizes the induction principle similar to a transformer's primary/secondary transfer. In a transformer, the primary and secondary windings are on a common, closed ferromagnetic core. CPS® tech-

nology, on the other hand, „stretches“ the primary winding to a long loop and places the secondary winding onto an open ferromagnetic core. This allows relative motion of the two windings. The transmission characteristics are optimized by using a high transmission frequency of 20 kHz.

## CPS® TECHNOLOGY

### CONVENTIONAL TRANSFORMER

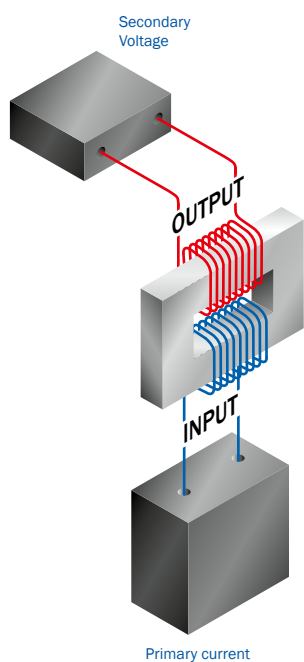

### E-SHAPED PICKUP

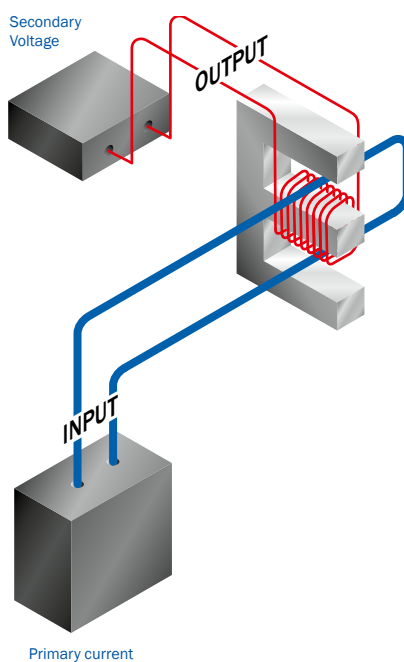

### FLAT PICKUP

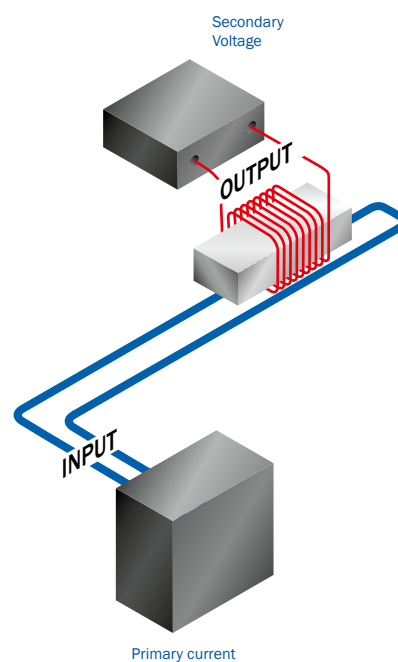

## CPS® – SYSTEM OVERVIEW

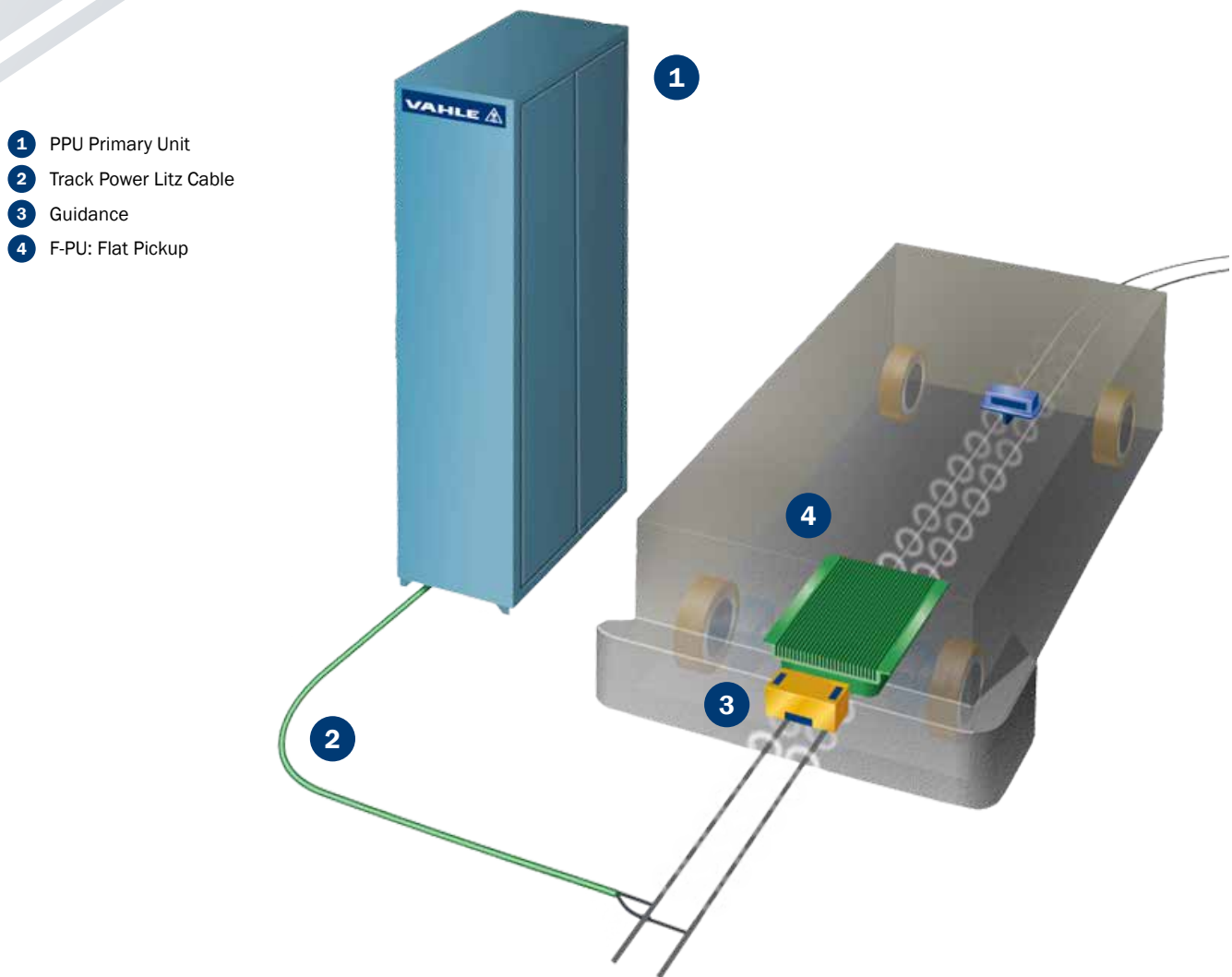

- 1 PPU Primary Unit
- 2 Track Power Litz Cable
- 3 Guidance
- 4 F-PU: Flat Pickup

## PRIMARY EQUIPMENT – OVERVIEW

### CABINET PRIMARY INVERTER

As the centerpiece of the contactless power supply, the primary inverter delivers the required electrical power for all mobile consumers located on the track. Standard three-phase alternating current of 400V/50Hz (or different regional standards) is initially converted to single-phase alternating current of 20kHz and then fed to the primary cable at a constant current of 70A. A suitable diagnostics interface is available for displaying or monitoring the actual operating condition.

#### COMPLETE CABINET 45 KW / 11 KW

- Cabinet ready for use
- Technical design depending on installed system
- Design according to customer specifications
- Several cabinets can be interconnected for large systems with a high power requirements

#### MOUNTING PLATE 45 KW / 11 KW

- All 20 kHz CPS® components are pre-mounted and completely wired
- Installation in an existing power switch cabinet
- Supply with 400V, three-phase alternating current
- 20 kHz output for supplying the primary loop

# PRIMARY POWER UNIT

## TECHNICAL DATA

### ELECTRICAL DATA

Power (nominal/peak) ..... 8.8 kW / 11 kW (PPU11K)

Power (nominal/peak) ..... 36 kW / 45 kW (PPU45K)

Supply voltage ..... 3 x 400 VAC

### MECHANICAL DATA

Dimension ..... 2000 x 1200 x 500 mm + 200 mm socket  
(complete cabinet)

1900 x 700 mm (mounting plate)

Temperature range ..... 0 – 30 °C

Protection Type ..... IP54 (complete cabinet)

IP00 (mounting plate)



Complete cabinet



Mounting plate

## PPU45K – 45 kW

### RANGE OF PRODUCTS

Description				Order No.
124 A	HF50	PPU45k.1-020-124-A-IO	Primary power unit 45 kW / Terminal screw for standard application / 20 kHz / 124 A / Stand alone / Digital IOs / Track compensation not included	10022379
		PPU45k.3-020-124-A-IO	Primary power unit 45 kW / Terminal screw for PU22 application / 20 kHz / 124 A / Stand alone / Digital IOs / Track compensation not included	10022796
		PPU45k.1-020-124-M-IO	Primary power unit 45 kW / Terminal screw for standard application / 20 kHz / 124 A / Sync-Master / Digital IOs / Track compensation not included	10022797
		PPU45k.1-020-124-U-IO	Primary power unit 45 kW / Terminal screw for standard application / 20 kHz / 124 A / Sync-Sub-Slave / Digital IOs / Track compensation not included	10022380
		PPU45k.1-020-124-S-IO	Primary power unit 45 kW / Terminal screw for standard application / 20 kHz / 124 A / Sync-Slave / Digital IOs / Track compensation not included	10022800
72 A	HF25	PPU45k.1-020-072-A-IO	Primary power unit 45 kW / Terminal screw for standard application / 20 kHz / 72 A / Stand alone / Digital IOs / Track compensation not included	10022802
		PPU45k.1-020-072-M-IO	Primary power unit 45 kW / Terminal screw for standard application / 20 kHz / 72 A / Sync-Master / Digital IOs / Track compensation not included	10022803
		PPU45k.1-020-072-U-IO	Primary power unit 45 kW / Terminal screw for standard application / 20 kHz / 72 A / Sync-Sub-Slave / Digital IOs / Track compensation not included	10022804
		PPU45k.1-020-072-S-IO	Primary power unit 45 kW / Terminal screw for standard application / 20 kHz / 72 A / Sync-Slave / Digital IOs / Track compensation not included	10022805
	PL8x4	PPU45k.2-020-072-A-IO	Primary power unit 45 kW / Feed-through terminal for standard application / 20 kHz / 72 A / Stand alone / Digital IOs / Track compensation not included	10022801
		PPU45k.2-020-072-M-IO	Primary power unit 45 kW / Feed-through terminal for standard application / 20 kHz / 72 A / Sync-Master / Digital IOs / Track compensation not included	10022821
		PPU45k.2-020-072-U-IO	Primary power unit 45 kW / Feed-through terminal for standard application / 20 kHz / 72 A / Sync-Sub-Slave / Digital IOs / Track compensation not included	10022807
		PPU45k.2-020-072-S-IO	Primary power unit 45 kW / Feed-through terminal for standard application / 20 kHz / 72 A / Sync-Slave / Digital IOs / Track compensation not included	10022808

## PPU11K – 11 KW

### RANGE OF PRODUCTS

Description			Order No.	
124 A	HF50	PPU11k.1-020-124-A-IO	Primary power unit 11 kW / Terminal screw for standard application / 20 kHz / 124 A / Stand alone / Digital IOs / Track compensation not included	10022809
		PPU11k.1-020-124-M-IO	Primary power unit 11 kW / Terminal screw for standard application / 20 kHz / 124 A / Sync-Master / Digital IOs / Track compensation not included	10022810
		PPU11k.1-020-124-U-IO	Primary power unit 11 kW / Terminal screw for standard application / 20 kHz / 124 A / Sync-Sub-Slave / Digital IOs / Track compensation not included	10022811
		PPU11k.1-020-124-S-IO	Primary power unit 11 kW / Terminal screw for standard application / 20 kHz / 124 A / Sync-Slave / Digital IOs / Track compensation not included	10022812
72 A	HF25	PPU11k.1-020-072-A-IO	Primary power unit 11 kW / Terminal screw for standard application / 20 kHz / 72 A / Stand alone / Digital IOs / Track compensation not included	10022813
		PPU11k.1-020-072-M-IO	Primary power unit 11 kW / Terminal screw for standard application / 20 kHz / 72 A / Sync-Master / Digital IOs / Track compensation not included	10022814
		PPU11k.1-020-072-U-IO	Primary power unit 11 kW / Terminal screw for standard application / 20 kHz / 72 A / Sync-Sub-Slave / Digital IOs / Track compensation not included	10022815
		PPU11k.1-020-072-S-IO	Primary power unit 11 kW / Terminal screw for standard application / 20 kHz / 72 A / Sync-Slave / Digital IOs / Track compensation not included	10022816
	PL8x4	PPU11k.2-020-072-A-IO	Primary power unit 11 kW / Feed-through terminal for standard application / 20 kHz / 72 A / Stand alone / Digital IOs / Track compensation not included	10022817
		PPU11k.2-020-072-M-IO	Primary power unit 11 kW / Feed-through terminal for standard application / 20 kHz / 72 A / Sync-Master / Digital IOs / Track compensation not included	10022818
		PPU11k.2-020-072-U-IO	Primary power unit 11 kW / Feed-through terminal for standard application / 20 kHz / 72 A / Sync-Sub-Slave / Digital IOs / Track compensation not included	10022819
		PPU11k.2-020-072-S-IO	Primary power unit 11 kW / Feed-through terminal for standard application / 20 kHz / 72 A / Sync-Slave / Digital IOs / Track compensation not included	10022820

## TRACK COMPENSATION (MOUNTING PLATE)

### RANGE OF PRODUCTS

Description		Order No.
P-SK-0220NF-0400-015-028-300-000-0-000+V	Tuning-Compensation for PPU15...28X220NF	0915125-9
P-SK-0150NF-0600-015-028-300-000-0-000+V	Tuning-Compensation for PPU15...28X150NF	0915125-8
P-SK-0100NF-0600-015-028-300-000-0-000+V	Tuning-Compensation for PPU15...28X100NF	0915125-7
P-SK-0068NF-0650-015-028-300-000-0-000+V	Tuning-Compensation for PPU15...28X68NF	0915125-6
P-SK-0047NF-0650-015-028-300-000-0-000+V	Tuning-Compensation for PPU15...28X47NF	0915125-5

## PRIMARY EQUIPMENT CONFIGURATION

The primary inverter units shown here are generally suitable for all areas of application indicated in this catalog. From a technical and economical aspect, an optimum adaptation to the respective conditions of a specific installation is assured due to an available, wide-ranging performance grading scale. Whether a complete cabinet is needed or a mounting plate – our experienced project team will always be glad to help you selecting the best suitable components.





Primary equipment can be configured for installations with one segment (stand alone) or for installations with several segments.

A system with two segments consists of a master unit and a slave unit. A system with more than two segments consists of a master unit, sub-slave units and a slave unit.

Examples: System with two segments: 1x master and 1x slave.

System with four segments: 1x master, 2x sub-slave and 1x slave

### CONFIGURATION FOR 124 A

System with one segment		System with several segments		
Stand alone	Stand alone PU22	Master	Sub-Slave	Slave
Primary cable HF50				
PPU45k.1-020-124-A-IO	PPU45k.3-020-124-A-IO	PPU45k.1-020-124-M-IO	PPU45k.1-020-124-U-IO	PPU45k.1-020-124-S-IO
PPU11k.1-020-124-A-IO		PPU11k.1-020-124-M-IO	PPU11k.1-020-124-U-IO	PPU11k.1-020-124-S-IO
				
F-Pickup	E-Pickup	F-Pickup	F-Pickup	F-Pickup

### CONFIGURATION FOR 72 A

System with one segment	System with several segments		
Stand alone	Master	Sub-Slave	Slave
Primary cable HF25			
PPU45k.1-020-072-A-IO	PPU45k.1-020-072-M-IO	PPU45k.1-020-072-U-IO	PPU45k.1-020-072-S-IO
PPU11k.1-020-072-A-IO	PPU11k.1-020-072-M-IO	PPU11k.1-020-072-U-IO	PPU11k.1-020-072-S-IO
			
U-Pickup	U-Pickup	U-Pickup	U-Pickup
Primary cable PL8x4			
PPU45k.2-020-072-A-IO	PPU45k.2-020-072-M-IO	PPU45k.2-020-072-U-IO	PPU45k.2-020-072-S-IO
PPU11k.2-020-072-A-IO	PPU11k.2-020-072-M-IO	PPU11k.2-020-072-U-IO	PPU11k.2-020-072-S-IO
			
F-Pickup system	F-Pickup system	F-Pickup system	F-Pickup system

## TRACK EQUIPMENT

### TRACK COMPENSATION

- Compact design
- Positioning near track possible
- A box is required every 33 to 44 m

#### TRACK COMPENSATION KB 10.1

Dimensions (LxWxH) ..... 194 x 154 x 100

Protection Type ..... IP65

Weight ..... 1.5 kg

Track current ..... 72 A



Track Power Compensation Box

#### TRACK COMPENSATION KB 10.4

Dimensions (LxWxH) ..... 2x 440 x 156 x 110

Protection Type ..... IP54

Weight ..... 4 kg

Track current ..... 124 A

## PRIMARY CABLE

#### PRIMARY CABLE 8X4

Application ..... Floor skid conveyor

Diameter ..... 15.7 mm

Weight ..... 0.49 kg/m



- For standard applications
- Single insulated copper conductors
- Easy installation with standard cable tools

#### PRIMARY CABLE HF 25

Application ..... EMS

Diameter ..... 11 mm

Weight ..... 0.28 kg/m



- For EMS and sortation technology applications
- Special conductor made of single insulated copper braid
- Small outside diameter

#### PRIMARY CABLE HF 50

Application ..... Floor skid conveyor/  
crane installations

Diameter ..... 16.5 mm

Weight ..... 0.56 kg/m



- For very long track sections
- Special conductor made of single insulated copper braid
- Very low power loss due to large conductor cross section



## LAYOUT METHODS

### INSTALLED INSIDE VEHICLE GUIDE TRACK

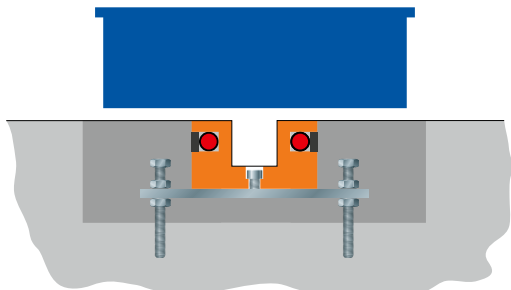

### CABLE INSTALLED DIRECTLY INTO THE FLOOR

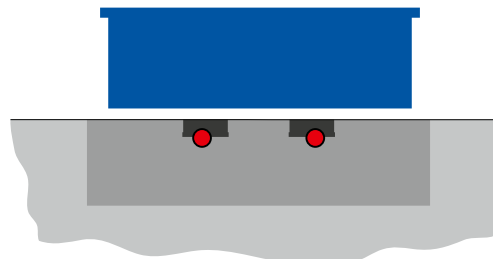

### CABLE ON SPECIAL SUPPORT

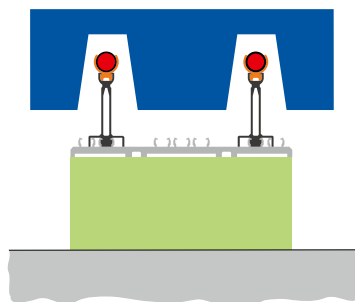

### CABLE IN AN EMS PROFILE

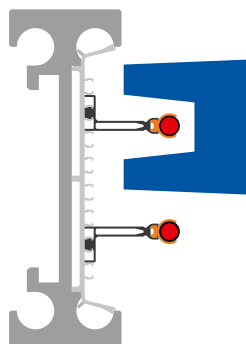

## RANGE OF PRODUCTS

Description		Order No.
P-KB-KB10.4-2M25-1μ5-440-312-110-4-M03+V	Track Power Compensation Box for 124 A / 20 kHz	10013900
P-KB-KB10.1-2M25-1μ5-245-156-110-4-M03+V	Track Power Compensation Box for 72 A / 20 kHz	0915461
LT-PL04.000-0000-19-00-00-GY+V	Track Power Litz Cable / 20 kHz / 72 A / 20 kHz CPS®PL04 8x4 mm <sup>2</sup> / 15.7mm ±0.3 mm / UL-CSA	10021712
LT-PL25.000-0000-20-00-00-BK+V	Track Power Litz Cable / 20 kHz / 72 A / 20 kHz CPS®PL25 Cross section: 4x6x33x0.20mm / 10.7 mm ±0.4 mm	10021713
LT-PL50.000-0000-20-00-00-BK+V	Track Power Litz Cable / 20 kHz / 124 A / 20kHz CPS®PL50 Cross section: 8x4x50x0.20mm / 16.5mm ±0.5mm	10021715

## VEHICLE EQUIPMENT FOR 24 V / 27 V F-PICKUP PS08 WITH INTEGRATED REGULATOR

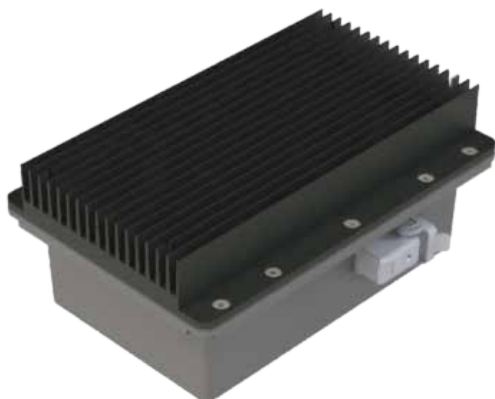

### BLOCK DIAGRAM

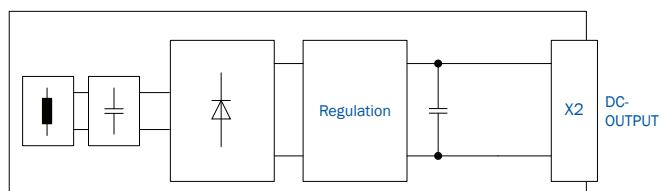

### RANGE OF PRODUCTS

Description		Order No.
PS08-0027V019AD-00000000-1C103-00310+V	PS08 / 0.5 kW / 20 kHz / Track conductor spacing 80 mm / integrated Regulator / 27 VDC / 19 A max / Battery Charging	0915429-3E21
PS08-0600W024VD-00000000-1C102-00300+V	PS08 / 0.6 kW / 20 kHz / Track conductor spacing 80 mm / integrated Regulator / 24 VDC / 25 A max	0915429-1A11
AL-5X2,5	Cable connection between PS08 and external application	see page 22

## TECHNICAL DATA

### ELECTRICAL DATA

Peak power.....	0.6 / 0.5 kW
Nominal power .....	0.35 kW
Output voltage.....	24 / 27 VDC $\pm$ 5 %
Output current max.....	25 / 19 A
Duty cycle.....	depending on cooling
Track current .....	72 A
Track frequency.....	20 kHz
Track conductor spacing.....	80 mm

### PROTECTION

Output over current.....	Yes
Max. reverse voltage.....	30 VDC

### PICKUP SYSTEM MECHANICAL DATA

Dimension.....	310 x 210 x 133 mm
Mounting holes.....	120 x 290 mm / 160 x 190 mm
Weight.....	12.8 kg
Nominal airgap.....	20 mm
Vertical tolerances .....	-20 mm @ 100%, +10 mm derating
Lateral tolerances .....	$\pm$ 15 mm @ 100%, $\pm$ 30 mm derating
Protection rating.....	IP20 with open plug connection IP54 with plug connected
Ambient temperature.....	0... +30 °C non-condensing
Environment .....	General industrial
Cooling.....	Natural convection

## DIMENSIONS

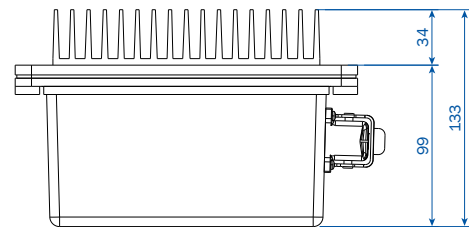
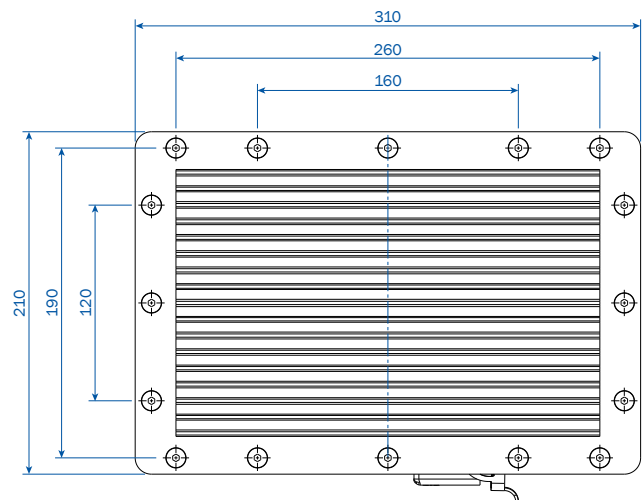
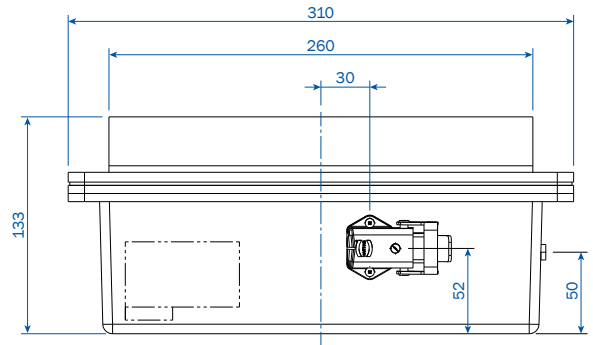

## VEHICLE EQUIPMENT FOR 24 V / 28.2 V / 56.2 V F-PICKUP PS27.1 WITH INTEGRATED REGULATOR

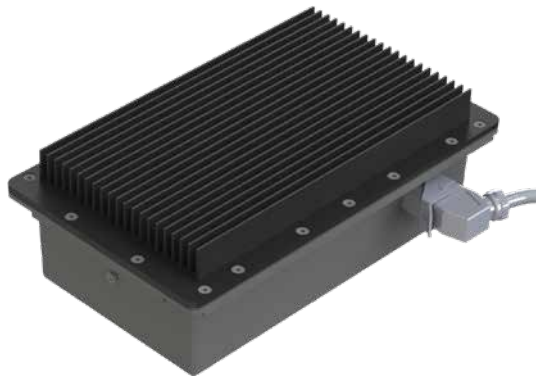

### BLOCK DIAGRAM

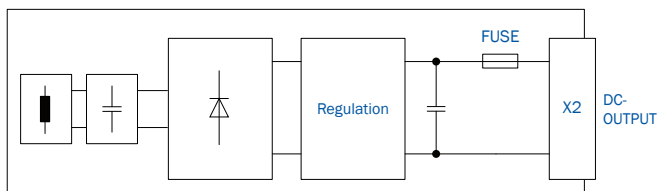

### RANGE OF PRODUCTS

Description		Order No.
PS27.1-1000W024VD-00000000-1A002-0030L+V	PS27.1 / 1 kW / 20 kHz / Track conductor spacing 100 mm / integrated Regulator / 24VDC / 42A max	10011549
PS27.1-28.2V036AD-00000000-1B002-0031L+V	PS27.1 / 1 kW / 20 kHz / Track conductor spacing 100 mm / integrated Regulator / 28.2VDC / 36A max. / Battery Charging	10014177
PS27.1-56.2V020AD-00000000-1B002-0031L+V	PS27.1 / 1 kW / 20 kHz / Track conductor spacing 100 mm / integrated Regulator / 56.2VDC / 20A / Battery Charging	10014214
AL-7G2,5	Cable connection between PS27.1 and external application	see page 22

## TECHNICAL DATA

### ELECTRICAL DATA

Peak power.....	1 kW (10 s)
Nominal power .....	0.6 kW
Output voltage.....	24 / 28.2 / 56.2 VDC $\pm 10\%$
Output current max.....	46.5 / 40 / 20 A
Duty cycle.....	40% Duty (10 min cycle)
Track current .....	72 A
Track frequency.....	20 kHz
Track conductor spacing.....	100 mm

### PROTECTION

Output over current.....	Yes
Max. reverse voltage.....	30 VDC

### PICKUP SYSTEM MECHANICAL DATA

Dimension.....	405 x 245 x 142 mm
Mounting holes.....	225 x 280 mm
Weight.....	16 kg
Nominal airgap.....	15 mm
Vertical tolerances .....	-15 mm @ 100%, +20 mm derating
Lateral tolerances .....	$\pm 30$ mm derating
Protection rating.....	IP20 with open plug connection IP54 with plug connected
Ambient temperature.....	0... +30 °C non-condensing
Environment .....	General industrial
Cooling .....	Natural convection

## DIMENSIONS

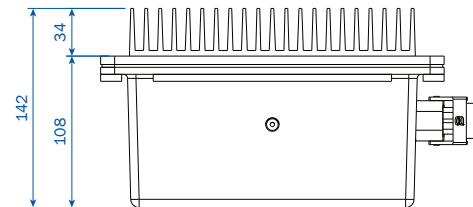
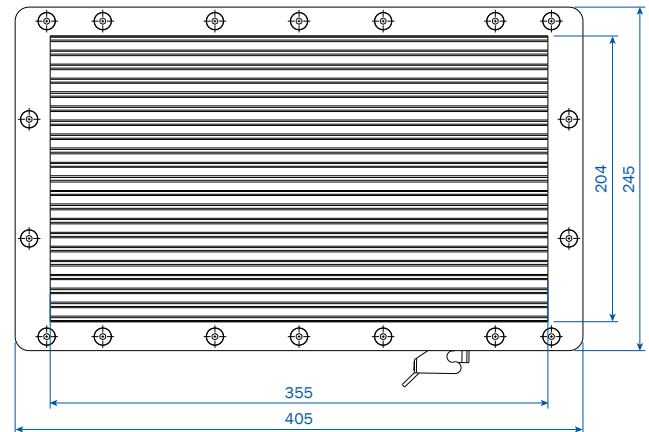
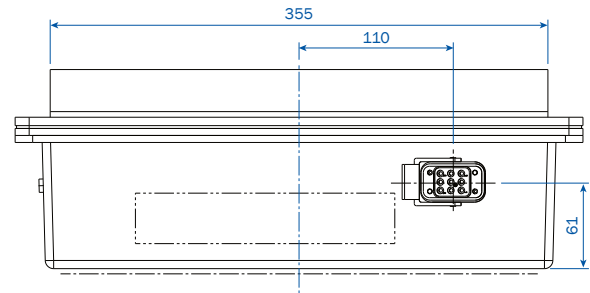

## VEHICLE EQUIPMENT FOR 560 V F-PICKUP F330 AND REGULATOR RE330



### BLOCK DIAGRAM

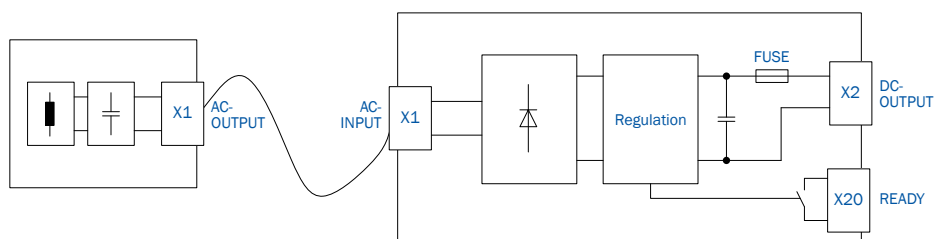

### RANGE OF PRODUCTS

Description		Order No.
vPOW_F330.1-020-124-04-L0-HV	F330 / 3.3 kW / 20 kHz / 124 A / Duty 40 % / Linear	10017749
vPOW_RE330.1-020-560-04-NI-ST-RC-NI	Regulator / 3.3 kW / 20 kHz / 560 V / Duty 40 % / No thermal monitoring / LITE / Relay contact / No Auxiliary	10017419
PX12	Cable connection between F330 and RE330	see page 22

## TECHNICAL DATA

### ELECTRICAL DATA

Peak power.....	3.3 kW
Nominal power.....	1.3 kW
Output voltage.....	560 VDC $\pm$ 5 %
Output current max.....	6.5 A
Duty cycle.....	40% duty (10 min cycle)
Track current.....	124 A
Track frequency.....	20 kHz
Track conductor spacing.....	100 mm

### PROTECTION

Output over voltage.....	Yes
Output over current.....	Yes
Max. reverse voltage.....	750 VDC

### REGULATOR MECHANICAL DATA

Dimension.....	190 x 120 x 87.4 mm
Mounting holes.....	180.5 x 80 mm
Weight.....	1 kg
Protection rating.....	IP20
Ambient temperature.....	0 ... +40 °C non-condensing
Environment.....	General industrial
Cooling.....	Forced convection

### PICKUP CONNECTION CABLE

Length.....	1/2/4/6 m
Outer diameter.....	11 mm
Connections.....	Pre-terminated
Application.....	Flexible
Min. bending radius.....	50 mm

### PICKUP MECHANICAL DATA

Dimension.....	415 x 255 x 66.5 mm
Mounting holes.....	385 x 225 mm
Weight.....	17 kg
Nominal airgap.....	15 mm (from top of track cable to bottom of pickup)
Vertical tolerances.....	$\pm$ 5 mm
Lateral tolerances.....	$\pm$ 20 mm
Protection rating.....	IP54
Ambient temperature.....	0 ... +40 °C non-condensing
Environment.....	General industrial
Cooling.....	Natural convection

## DIMENSIONS

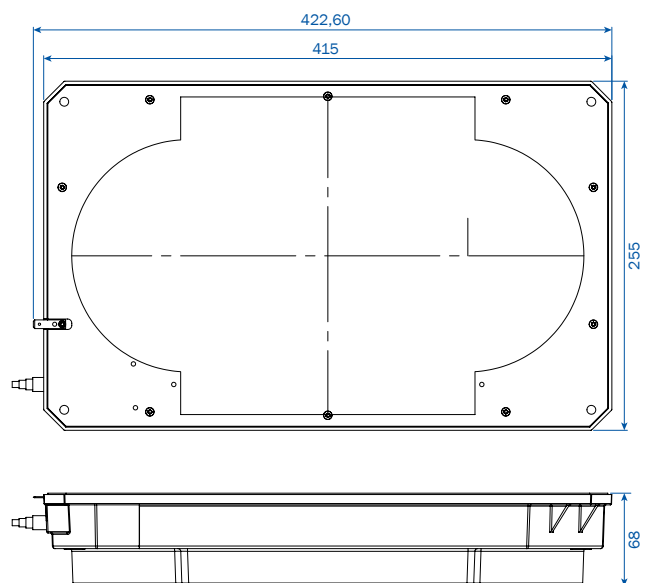
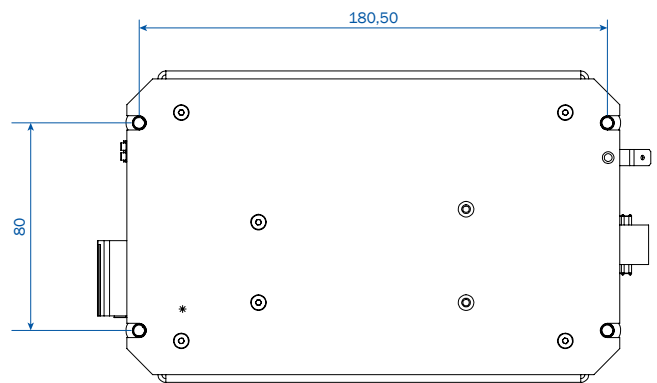
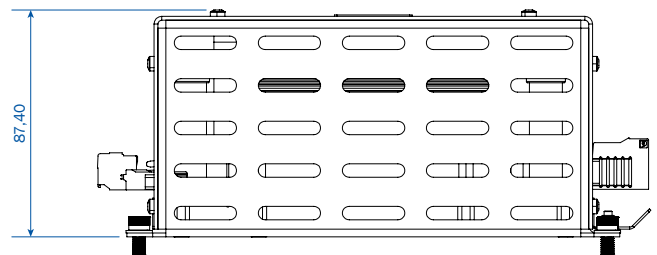
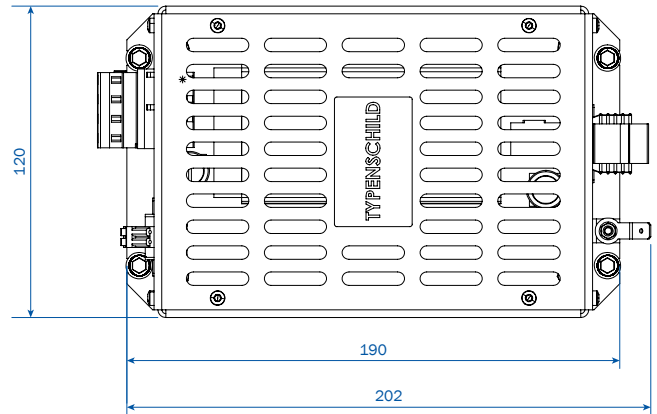

## VEHICLE EQUIPMENT FOR 48V U-PICKUP PK31 AND REGULATOR RE080



### BLOCK DIAGRAM

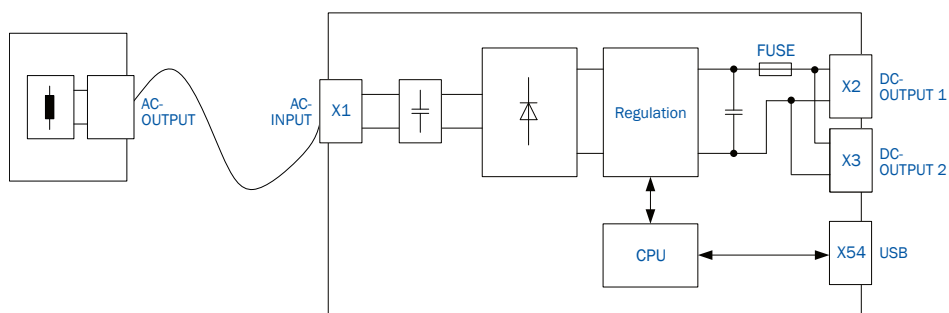

### RANGE OF PRODUCTS

Description		Order No.
PK31 -0900W110VA-VLPK1000-19I00-8000K+V	PK31 / 900 W / 20 kHz / Nominal power 400 W / 1 m connecting cable	10020600
RE080.1-20-048-03-UC-LI-NI-NI	Regulator / 0.8 kW / 20 kHz / Duty 30% / 48V / Thermal monitoring / LITE / Relay contact / No Auxiliary	10021229
AL-3G4	Cable connection between RE080 and external application	see page 22



## TECHNICAL DATA

### ELECTRICAL DATA

Peak power.....	0.8kW (5s)
Nominal power.....	0.26kW
Output voltage.....	48VDC $\pm$ 5%
Output current max.....	18A
Duty cycle.....	30% (10 min cycle)
Track current.....	72A
Track frequency.....	20kHz
Track conductor spacing.....	67mm

### PROTECTION

Output over voltage.....	Yes
Output over current.....	Yes
Over temperature.....	Yes

### REGULATOR MECHANICAL DATA

Dimension.....	304 x 220 x 94.5 mm
Mounting holes.....	204 x 175 mm
Weight.....	3.7 kg
Protection rating.....	IP20 with open plug connection IP54 with plug connected
Ambient temperature.....	5... +40°C non-condensing
Environment.....	General industrial
Cooling.....	Natural convection

### PICKUP CONNECTION CABLE

Length.....	1 m
Outer diameter.....	11.2 mm
Connections.....	Pre-terminated
Application.....	Flexible
Min. bending radius.....	40 mm

### PICKUP MECHANICAL DATA

Dimension.....	114 x 75 x 89.4 mm
Mounting holes.....	86 x 47 mm
Weight.....	1.6 kg
Nominal airgap.....	12.5 mm
Vertical tolerances.....	$\pm$ 3 mm
Lateral tolerances.....	+4 / -12.5 mm @ 100% > +4 mm derating
Protection rating.....	IP20 with open plug connection IP54 with plug connected
Ambient temperature.....	5... +40°C non-condensing
Environment.....	General industrial
Cooling.....	Natural convection

## DIMENSIONS

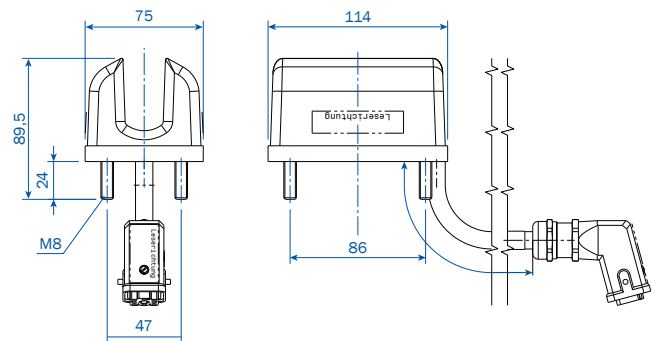
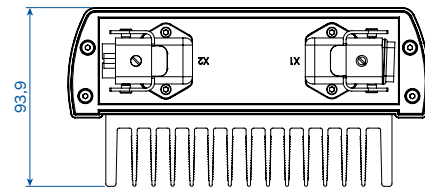
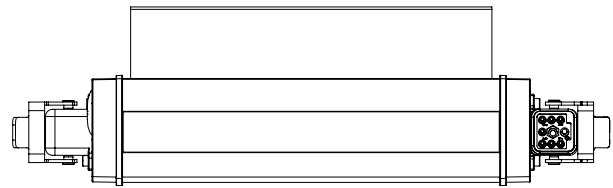
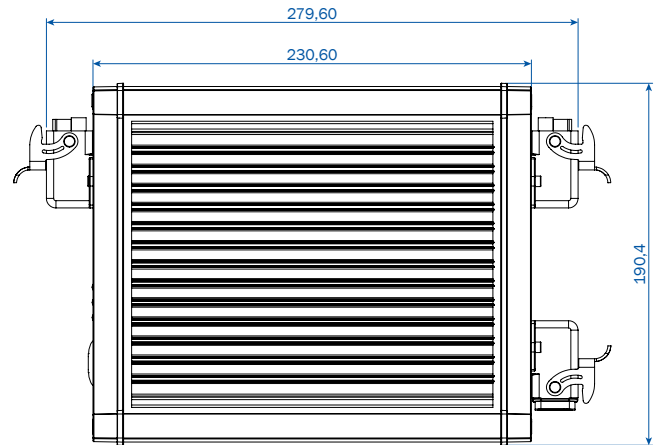

## VEHICLE EQUIPMENT FOR 560V E-PICKUP PUE4 AND REGULATOR RE55

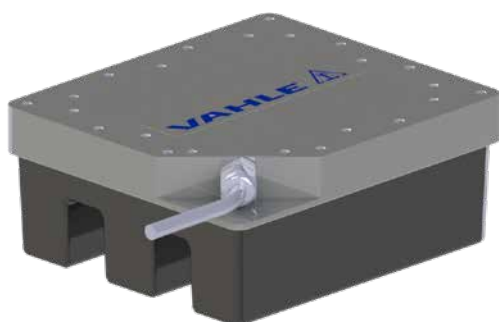

### BLOCK DIAGRAM

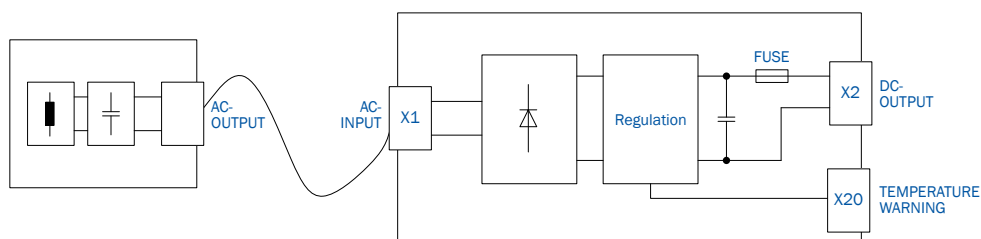

### RANGE OF PRODUCTS

Description		Order No.
PUE4-4000W270VA-00000000-12E00-00E00+V	PUE4 / 4 kW / 20 kHz / Nominal power 3.2 kW / 200 mm connecting cable	10005185
RE55.1-5500W560VD-000W00VD-11014-0030X+V	RE55.1 / 5.5 kW / 20 kHz / 560VDC	10016225
VL-7G2,5	Cable connections between PUE4 and RE55	see page 22

## TECHNICAL DATA

### ELECTRICAL DATA

Peak power.....	4 kW (5 s)
Nominal power.....	1.3 kW
Output voltage.....	560 VDC $\pm$ 10%
Output current max.....	8 A
Duty cycle.....	30% (10 min cycle)
Track current.....	72 A
Track frequency.....	20 kHz
Track conductor spacing.....	84 mm

### PROTECTION

Output over current.....	Yes
Max. reverse voltage.....	800 VDC

### REGULATOR MECHANICAL DATA

Dimension.....	282 x 247 x 169 mm
Mounting holes.....	215 x 214 mm
Weight.....	7.2 kg
Protection rating.....	IP20 with open plug connection IP54 with plug connected
Ambient temperature.....	5 ... +40 °C non-condensing
Environment.....	General industrial
Cooling.....	Natural convection

### PICKUP CONNECTION CABLE

Length.....	0.2/1/2/3/4.5 m
Outer diameter.....	13.4 mm
Connections.....	Pre-terminated
Application.....	Flexible
Min. bending radius.....	7.5 x D

### PICKUP MECHANICAL DATA

Dimension.....	260 x 230 x 110 mm
Mounting holes.....	206 x 236 mm
Weight.....	13.3 kg
Nominal airgap.....	5 mm
Vertical tolerances.....	$\pm$ 4 mm
Lateral tolerances.....	$\pm$ 7 mm
Protection rating.....	IP20 with open plug connection IP54 with plug connected
Ambient temperature.....	0 ... +30 °C non-condensing
Environment.....	General industrial
Cooling.....	Natural convection

## DIMENSIONS

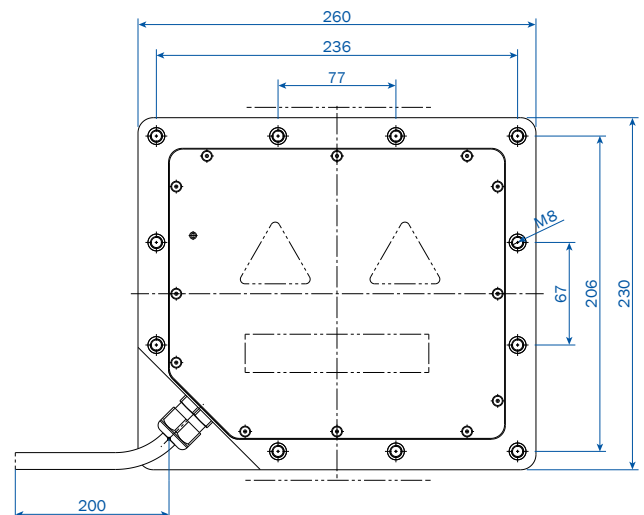
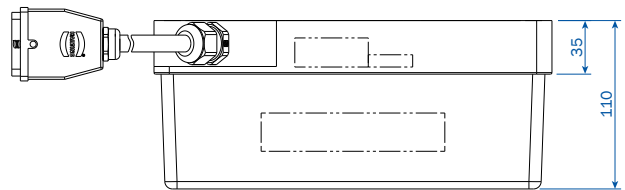
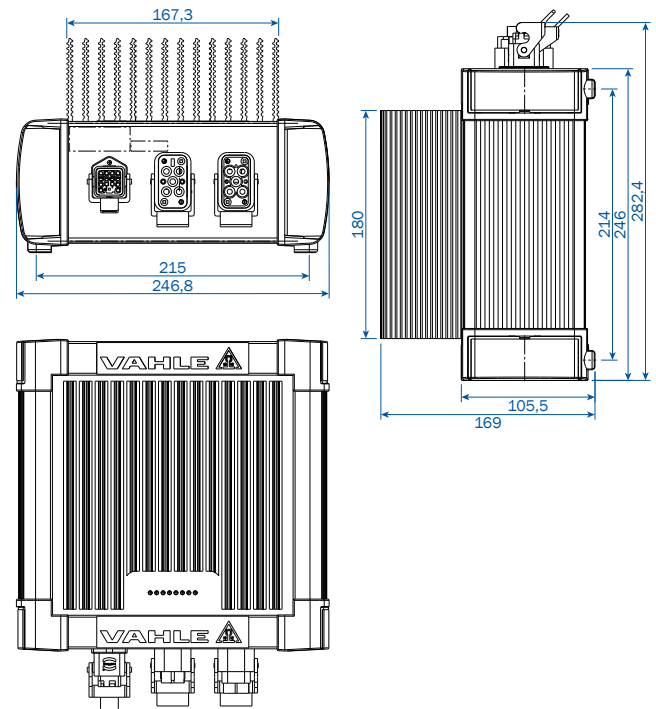

## VEHICLE EQUIPMENT FOR 288V / 560V E-PICKUP PU22 AND REGULATOR RE22

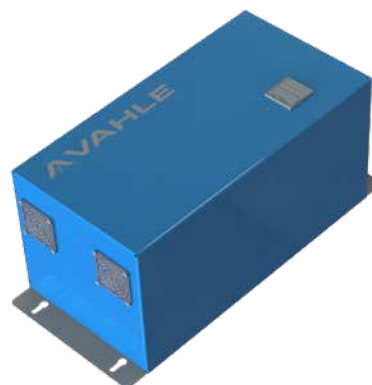
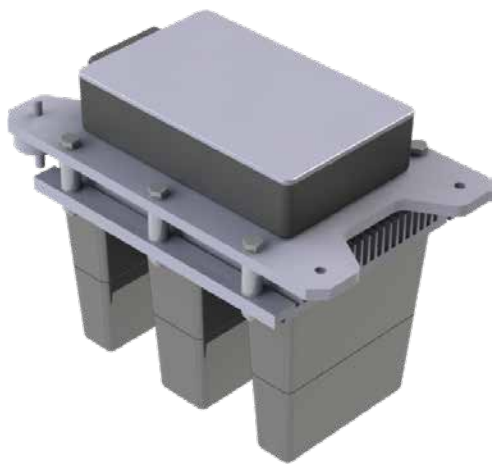

### BLOCK DIAGRAM

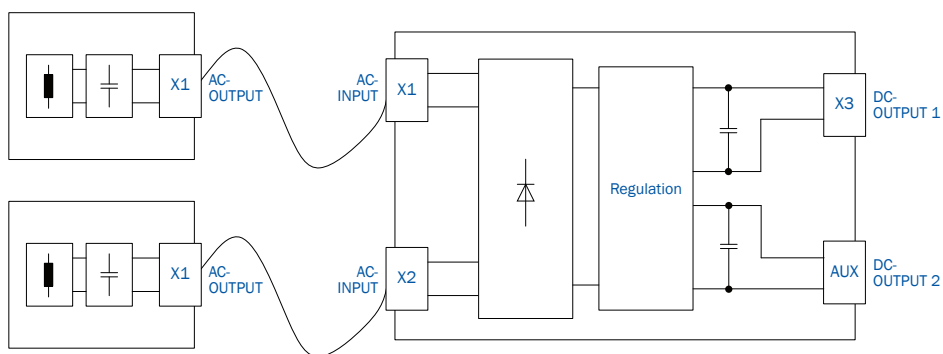

### RANGE OF PRODUCTS

Description		Order No.
PU22-022KW310VA-00000000-00000-00C00+V	PU22 / 22 kW / 20 kHz / Mounting on narrow side	0915007-120
PU22-022KW310VA-00000000-00000-00D00+V	PU22 / 22 kW / 20 kHz / Mounting on long side	0915007-220
RE22-040KW288VD-1K6W24VD-25A11-13400+V	RE22 / 40 kW / 20 kHz / 2x PU22 / 288VDC / Auxilliary / 1.6 kW / 24VDC	0915011-0218
RE22-040KW560VD-960W24VD-25A00-00400+V	RE22 / 40 kW / 20 kHz / 2x PU22 / 560VDC / Auxilliary / 0.19 kW / 24VDC	0915011-0200
AL-5G16	Cable connections between PU22 and RE22	see page 22

## TECHNICAL DATA

### ELECTRICAL DATA

Peak power.....	22/ 40 kW* (10 s)
Nominal power .....	10/ 25 kW*
Output voltage.....	288/ 560 VDC $\pm$ 10 %
Output current max.....	155/ 80 A
Track current .....	124 A
Track frequency.....	20 kHz
Track conductor spacing.....	133 mm

### PROTECTION

Output over voltage.....	Yes
Output over current.....	Yes

### REGULATOR ELECTRONIC MECHANICAL DATA

Dimension.....	328 x 660 x 290 mm
Mounting holes.....	200 x 630 mm
Weight.....	31.5 kg
Protection rating.....	IP20
Ambient temperature.....	0 ... +30 °C non-condensing
Environment .....	General industrial
Cooling.....	Forced convection

### PICKUP CONNECTION CABLE

Length.....	1.5/2/3/6/7 m
Outer diameter .....	24.2 mm
Connections.....	Pre-terminated
Application.....	Flexible
Min. bending radius .....	7.5 x D

### PICKUP MECHANICAL DATA

Dimension.....	420 x 250 x 322 mm (xxx-120) 320 x 350 x 322 mm (xxx-220)
Mounting holes.....	370 x 190 mm (xxx-120) 260 x 300 mm (xxx-220)
Weight.....	32.3 kg
Nominal airgap.....	27 mm $\pm$ 5 mm
Vertical tolerances .....	+18 mm/-15 mm
Lateral tolerances .....	$\pm$ 5 mm
Protection rating.....	IP54 with open plug IP65 with plug connected
Ambient temperature.....	0 ... +30 °C non-condensing
Environment .....	General industrial
Cooling.....	Natural convection

## DIMENSIONS

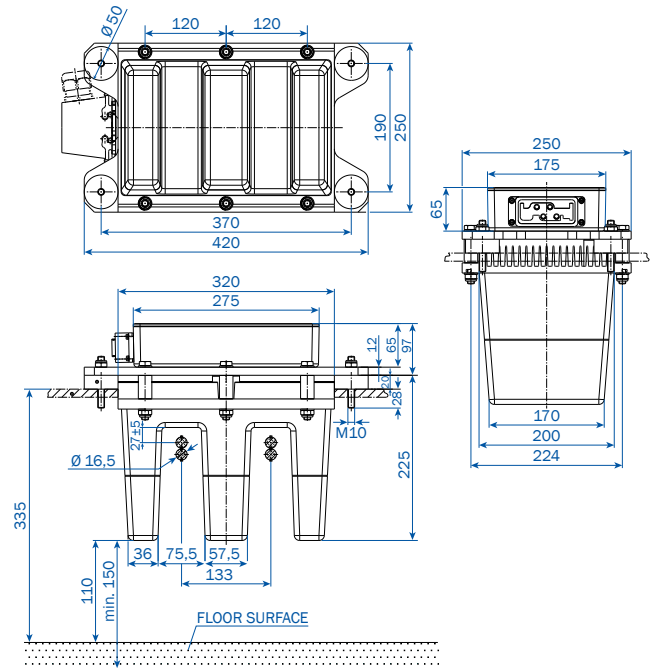

Variant PU22 xxx-120

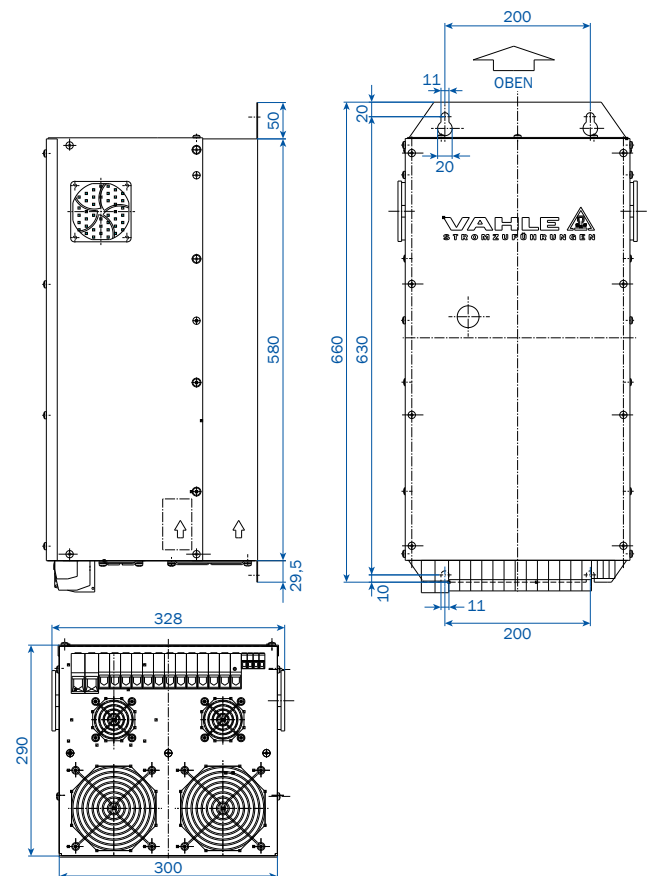

\* When using 2 pickups

## VEHICLE EQUIPMENT

### CABLE CONNECTION BETWEEN PICKUP AND REGULATOR



Power Cables

## RANGE OF PRODUCTS

Description		Order No.
AL-5X2,5000-5000-01-02-00-GR+V	Cable connection between PS08 and external application / 5.0 meter	0915089-0500
AL-7G2,5000-3000-06-05-00-GR-01+V	Cable connection between PS27.1 and external application / 3.0 meter	10011506
AL-7G2,5000-5000-06-05-00-GR-01+V	Cable connection between PS27.1 and external application / 5.0 meter	10015608
AL-5G2,5000-3000-33-56-00-GR-00+V	Cable connection between RE55 and external application / 3.0 meter	10013942
AL-5G2,5000-5000-33-56-00-GR-00+V	Cable connection between RE55 and external application / 5.0 meter	10014875
vPOW_PX12-10-SF	Cable connection between F330 and RE330 / 12 A / 1.0 meter / Spring terminal connection	10018436
vPOW_PX12-20-SF	Cable connection between F330 and RE330 / 12 A / 2.0 meter / Spring terminal connection	10018437
vPOW_PX12-40-SF	Cable connection between F330 and RE330 / 12 A / 4.0 meter / Spring terminal connection	10018438
vPOW_PX12-60-SF	Cable connection between F330 and RE330 / 12 A / 6.0 meter / Spring terminal connection	10018439
AL-3G4,0000-3000-07-67-00-GR+V	Cable connection between RE080 and external application / 3.0 meter	10009468
VL-7G2,5000-0200-06-60-08-SW-00+V	Cable connection between PUE4 and RE55 / 0.2 meter	10014874
VL-7G2,5000-1000-06-60-08-SW-00+V	Cable connection between PUE4 and RE55 / 1.0 meter	10013817
VL-7G2,5000-2000-06-60-08-SW-00+V	Cable connection between PUE4 and RE55 / 2.0 meter	10007727
VL-7G2,5000-3000-06-60-08-SW-00+V	Cable connection between PUE4 and RE55 / 3.0 meter	10012482
VL-7G2,5000-4500-06-60-08-SW-00+V	Cable connection between PUE4 and RE55 / 4.5 meter	10015584
AL-5G16,000-1500-03-10-00-GR+V	Cable connection between PU22 and RE22 / 1.5 meter	0915132-0150
AL-5G16,000-2000-03-10-00-GR+V	Cable connection between PU22 and RE22 / 2.0 meter	0915132-0200
AL-5G16,000-3000-03-10-00-GR+V	Cable connection between PU22 and RE22 / 3.0 meter	0915132-0300
AL-5G16,000-6000-03-10-00-GR+V	Cable connection between PU22 and RE22 / 6.0 meter	0915132-0600
AL-5G16,000-7000-03-10-00-GR+V	Cable connection between PU22 and RE22 / 7.0 meter	0915132-0700

## NOTES



A large grid of small dots for taking notes, covering most of the page. The dots are arranged in a regular pattern, forming a grid that is approximately 30 columns wide and 40 rows high. The dots are light gray and spaced evenly across the page.

---



**Paul Vahle GmbH & Co. KG**

Westicker Str. 52  
59174 Kamen  
Germany

Tel.: +49 2307 704-0  
Fax: +49 2307 704-444  
info@vahle.de

[www.vahle.com](http://www.vahle.com)